

IFI
522
1982

MECHANICAL TESTING OF BLIND RIVETS

BLIND
RIVETS

1. Scope.

1.1 Scope. This Standard describes procedures for the mechanical testing of blind rivets to determine properties required in the product standard.

1.2 The following tests are described:

- Shear strength, para. 2.1
- Tensile strength, para. 2.2
- Mandrel break load, para. 2.3
- Blind head formation, para. 2.4
- Mandrel retention, para. 2.5

1.3 Definitions of terms relating to blind rivets are given in IFI-110, "Glossary of Terms Relating to Blind Rivets," page H—1.

2. Test Methods.

2.1 Shear Test. The test shall be comprised of loading a single lap joint assembled with one rivet so that the direction of applied load induces transverse shear against the rivet body. The test specimen shall be mounted in a tensile testing machine capable of applying load at a controllable rate. The grips shall be self-aligning and care shall be taken when mounting the specimen to assure that the load will be transmitted in a straight line through the test rivet.

The specimen shall be tensile loaded at a speed of testing as determined with a free running cross head not less than 7 nor greater than 13 mm per minute. Loading shall be continued until failure of the rivet occurs. The maximum load in newtons applied to the specimen coincident with or prior to rivet failure shall be recorded as the ultimate shear strength of the rivet. At the discretion of the testing activity, tests need not be continued to destruction providing the test specimen supports the minimum ultimate shear load specified in the product standard without evidence of rivet failure.

The test specimen shall be comprised of two plates, of equal nominal thickness, axially aligned and assembled into a single lap joint with the test rivet, as shown in Figure 1. When testing rivets, except those covered in IFI-521, the total thickness of the joint shall not be less than 1.0 times the nominal rivet diameter

when testing protruding head rivets, or 1.5 times the nominal rivet diameter when testing flush head rivets nor be greater than the specified maximum grip length of the test rivet. When testing IFI-521 rivets the total thickness of the joint shall not be less than 1.5 times the nominal rivet diameter when testing protruding head rivets, or 2.0 times the nominal rivet diameter when testing flush head rivets nor be greater than the specified maximum grip length of the test rivet.

The test rivet shall be set with a setting tool standard for that type of rivet and in accordance with the setting procedures recommended by the rivet manufacturer.

2.2 Tensile Test. The test shall be comprised of separating two plates of a joint assembled with one blind rivet. The joint with the test rivet shall be installed in a test fixture, as shown in Figure 2, or other comparable arrangement if an alternate test fixture is used, and the fixture placed between the compression heads of a testing machine. For referee purposes the test fixture shown in Figure 2 shall be used. Care shall be exercised to locate the fixture at the center of the piston when hydraulic testing machines are used. Load shall be applied to the joint at a speed of testing, as determined with a free running cross head, not less than 7 nor greater than 13 mm per minute. Loading shall be continued to failure with failure occurring when the rivet body fractures or is pulled through one of the plates. The maximum load in newtons applied to the joint coincident with or prior to rivet failure shall be recorded as the ultimate strength of the rivet.

The test specimen shall be comprised of two plates, of equal nominal thickness, aligned and assembled into a joint with a test rivet. When testing rivets, except those covered in IFI-521, the total thickness of the joint shall not be less than 1.0 times the nominal rivet diameter when testing protruding head rivets, or 1.5 times the nominal rivet diameter when testing flush head rivets, nor be greater than the specified maximum grip length of the test rivet. When testing IFI-521 rivets the total thickness of the joint shall not be less than 1.5 times the nominal rivet diameter when testing protruding head rivets, or 2.0 times the nominal rivet diameter when testing flush

MECHANICAL TESTING OF BLIND RIVETS

IFI
522
1982

head rivets, nor be greater than the specified maximum grip length of the test rivet.

The test rivet shall be set with a setting tool which is standard for that type of rivet and in accordance with the setting procedures recommended by the rivet manufacturer.

2.3 Mandrel Break Load Test. The test rivet shall be installed in a test plate(s), and the assembly mounted in the fixture of a tensile testing machine. A suggested test fixture is illustrated in Figure 3. Load shall be applied

axially to the mandrel. Loading shall be continued until the mandrel breaks, and the maximum load occurring coincident with or prior to failure shall be recorded as the mandrel break load.

The test plate(s) may be of any material capable of supporting the test load without permanent deformation.

Thickness of test plate(s) shall be as close as practicable to the maximum of the grip range of the test rivet as specified in the application data tables in the product stan-

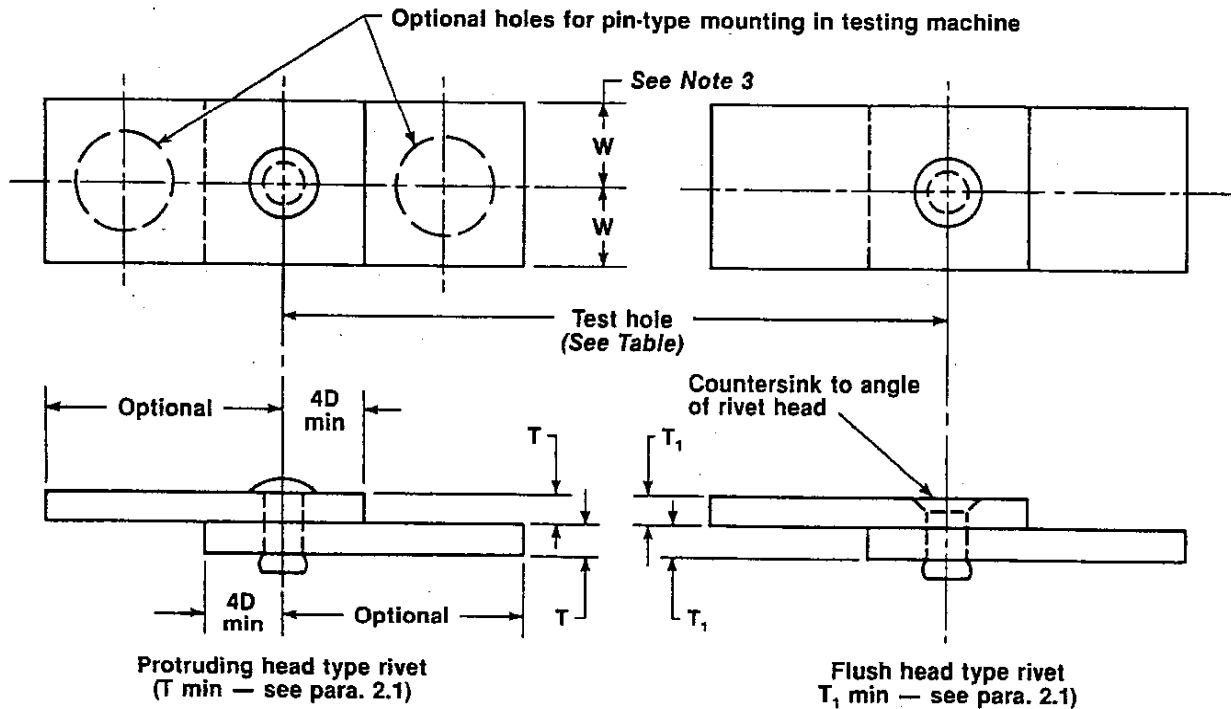

Rivet Series No.	Nom Rivet Size mm D	Test Hole Dia, mm	
		Max	Min
3	2.4	2.54	2.49
4	3.2	3.35	3.30
5	4.0	4.16	4.11
6	4.8	4.98	4.93
8	6.3	6.60	6.55

FIG. 1 TEST FIXTURE FOR SHEAR TESTING BLIND RIVETS

- NOTES: 1. Design of plates may be modified to add holes for shear testing two or more sizes of rivets using the same plates. Such holes shall be located on the longitudinal centerline of the plate, and center distances between adjacent holes shall be at least 4 times the diameter of the larger hole. Ends of plates may be drilled for pin-type mounting in testing machine.
2. Plates shall be of alloy steel, quenched and tempered to a hardness of Rockwell C46 to 50.
3. W for plates for testing IFI-521 rivets equals 25 mm, when testing all other rivets W equals 12.7 mm.



IFI
522
1982

MECHANICAL TESTING OF BLIND RIVETS

BLIND
RIVETS

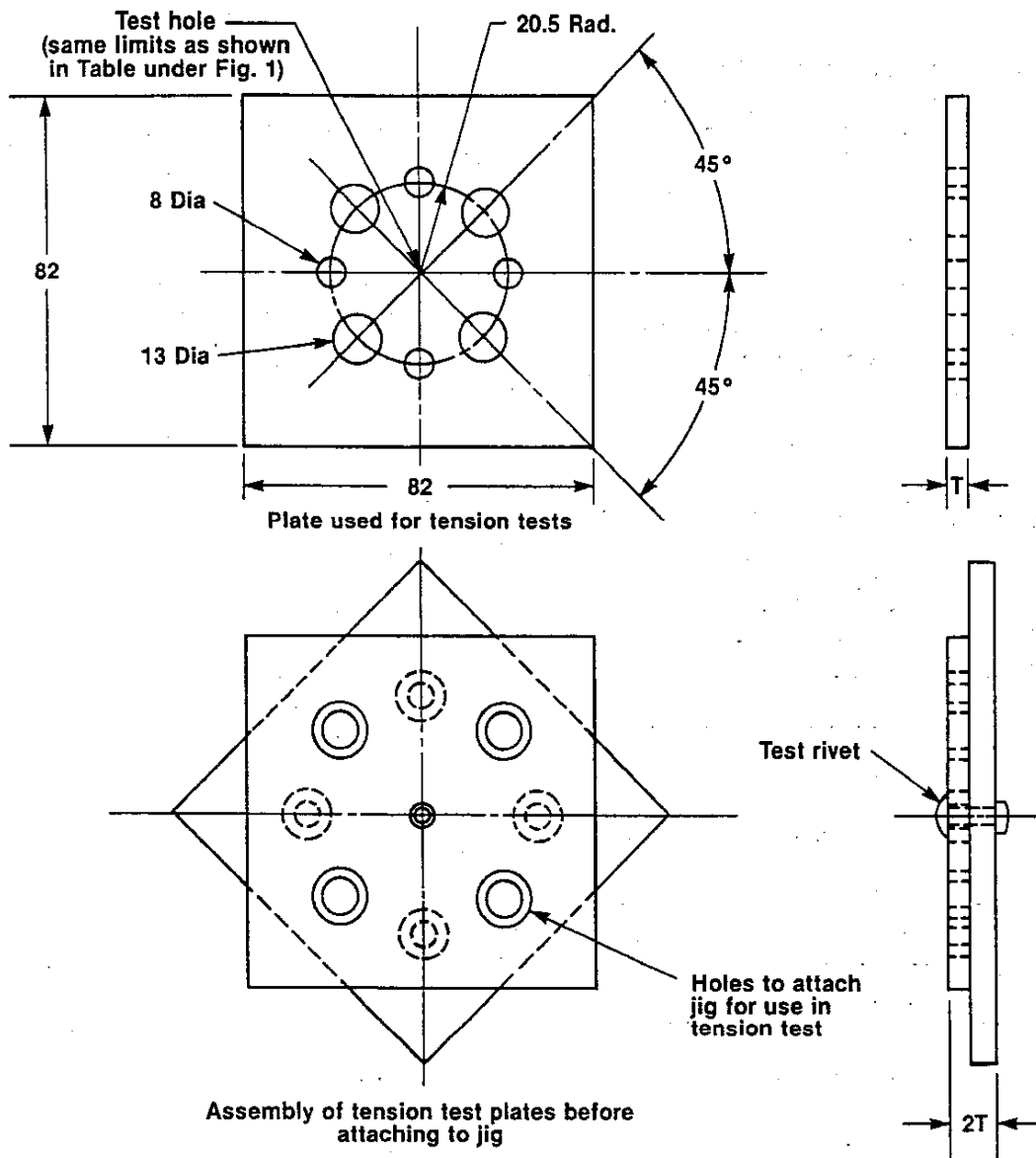

FIG. 2 TEST FIXTURE FOR TENSILE TESTING BLIND RIVETS

1. Dimensions are in millimeters.
2. Plates shall be of alloy steel, quenched and tempered to a hardness of Rockwell C46 to 50.
3. Minimum plate thickness "T" is specified in para. 2.2.

standard. The hole in test plate(s) shall conform to the recommended hole size given for the rivet size in the application data tables in the product standard.

The restraining plate shall be alloy steel, quenched and tempered to a hardness of Rockwell C42 to 46. The hole in the plate shall be

0.25 mm larger than the nominal mandrel diameter specified in the product standard.

2.4 Blind Head Formation Test.

2.4.1 The blind head formation load is a load applied to the mandrel sufficient to pull the mandrel head into the rivet body and initiate



MECHANICAL TESTING OF BLIND RIVETS

IFI
522
1982FIG. 3 TEST FIXTURE
FOR TESTING MANDREL
BREAK LOADS

FIG. 4 MANDREL RETENTION TEST FIXTURE

an expansion of the length of rivet body projecting beyond the blind side surface of the joined parts. When the formation of the blind side upset occurs there will normally be a period of tensile machine cross head travel with little or no increase in applied load.

2.4.2 The blind head formation test shall be conducted in conjunction with the mandrel break load test (2.3). As the load is being applied to the mandrel of the test rivet, the load at which it is visually observed that the rivet body end is upset or otherwise deformed to form a head on the blind side shall be recorded as the blind head formation load.

2.5 Mandrel Retention Test. The test rivet shall be installed in a test plate(s), and the assembly mounted on a test block. A suggested fixture is shown in Figure 4. A load equal to the mandrel retention load specified in the

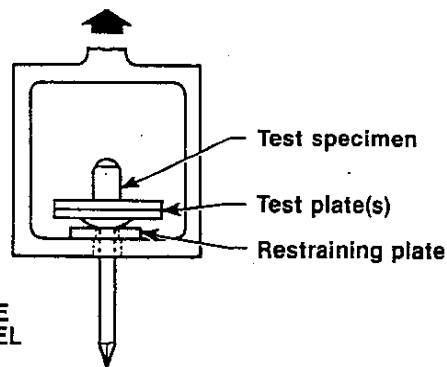
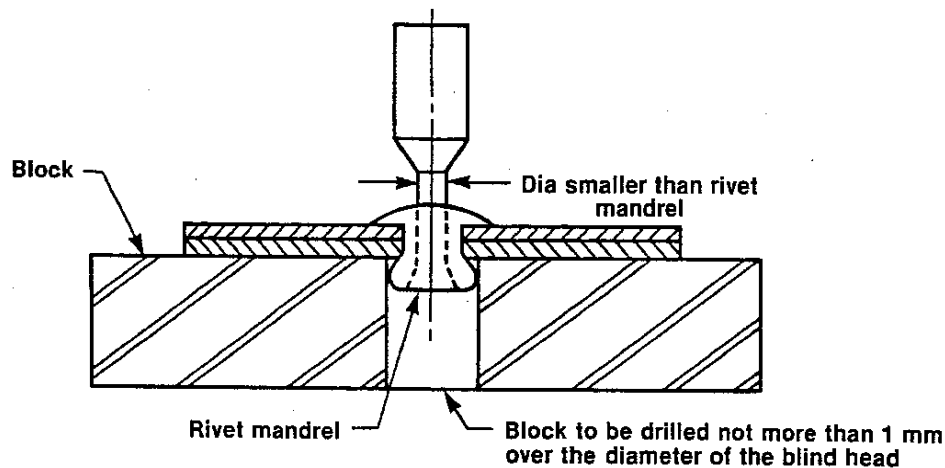
product standard shall be applied to the untrimmed mandrel from the top of the rivet, and the mandrel shall support this load without apparent movement with respect to the rivet body. During testing the load shall be applied steadily without impact, and care shall be exercised that the load is applied directly in line with the axis of the mandrel.

The test assembly may comprise one or more plates with a total thickness equal to the specified minimum grip length of the test rivet, except that no plate shall have a nominal thickness less than 1.5 mm. Test plates shall be aluminum alloy 2024T4. The rivet hole shall be drilled to the maximum test hole diameter shown in Figure 1 within a tolerance of plus 0.00 mm and minus 0.03 mm. When setting the rivet, care shall be taken to assure that the force of the setting device is applied directly in line with the axis of the mandrel.