

Seamless circular tubes made from steels with low temperature toughness

Technical delivery conditions

DIN
17 173

Nahtlose kreisförmige Rohre aus kaltzähnen Stählen; technische Lieferbedingungen

In keeping with current practice in standards published by the International Organization for Standardization (ISO), a comma has been used throughout as the decimal marker.

See Explanatory notes for connection with Standard ISO 2604/2 – 1975 published by the International Organization for Standardization (ISO).

The subclauses marked with a single dot • give specifications which are to be agreed upon at the time of ordering.

The subclauses marked with two dots •• give specifications which are optional and may be agreed upon at the time of ordering.

Contents

	Page	Page
1 Field of application	1	5.8 Leak tightness
2 General	1	5.9 Non-destructive testing
2.1 Concept	1	5.10 Dimensions, masses per unit length and permissible deviations
2.2 Test classes	1	6 Testing and documents on materials testing
3 Classification into grades	1	6.1 General
4 Designation and ordering	2	6.2 Test site
5 Requirements	2	6.3 Scope of test programme
5.1 Manufacturing process	2	6.4 Sampling and sample preparation
5.2 As delivered condition	2	6.5 Test procedure
5.3 Chemical composition	2	6.6 Retests
5.4 Mechanical properties	2	6.7 Documents on materials testing
5.5 Technological properties	4	7 Marking
5.6 Weldability	4	8 Complaints
5.7 Appearance of surface	4	

1 Field of application

1.1 This standard applies to seamless circular tubes made from carbon and alloy steels with low temperature toughness, as listed in table 1, for low temperature applications. These tubes are predominantly used in the construction of chemical plant, vessels, pipework and for general mechanical engineering purposes.

Note. Seamless fine grain steel tubes (see DIN 17 179) and seamless stainless austenitic steel tubes (see DIN 17 458) are also used for low temperature applications.

1.2 If tubes complying with the requirements of this standard are intended for use in installations subject to regular inspection, the specifications in the relevant codes of practice shall be taken into consideration, e.g. the *Technische Regeln Druckbehälter* (Technical rules for pressure vessels), *Merkblätter der Arbeitsgemeinschaft Druckbehälter (AD-Merkblätter)* (Instruction sheets of the pressure vessels Study Group) (AD Instruction sheets), *Technische Regeln für brennbare Flüssigkeiten* (Technical rules on combustible liquids), *Technische Regeln Druckgase* (Technical rules on pressure gases).

The same applies for other fields of application for which additional specifications exist.

2 General

2.1 Concept

For the purposes of this standard, steels with low temperature toughness are steels for which a minimum value of impact energy of 40J in the as delivered condition is stated for ISO V-notch test pieces taken in the longitudinal direction at a temperature of -40°C or lower.

2.2 Test classes

The tubes may be supplied in test class 1 or test class 2. Test class 2 tubes are distinguished from test class 1 tubes in that they are subjected to non-destructive testing.

• The selection of the test class is at the purchaser's discretion.

3 Classification into grades

3.1 This standard covers tubes made from the steel grades listed in table 1.

3.2 • The selection of the steel grade is at the purchaser's discretion.

Continued on pages 2 - 3

3.2.1 The factors taken into consideration when selecting the steel grade shall include not only the operating temperature, but also the overall stressing on the tubes (e.g. also that resulting from stresses set up by the design and the manufacturing processes).

3.3 Any relevant specifications, codes of practice or technical rules (e.g. *AD-Merkblatt W10*) relating to the application of the steel grade shall be taken into consideration when selecting the steel grade in accordance with this standard.

4 Designation and ordering

4.1 The standard designation for tubes complying with this standard shall give in the following order:

- the term "tube";
- DIN number of the dimensional standard (e.g. DIN 2448);
- characteristic dimensions of the tube (outside diameter X wall thickness);
- number of the DIN Standard giving the technical delivery conditions (DIN 17 173);
- symbol or material number identifying the steel grade (see table 1).

Example:

A seamless tube conforming to this standard, with an outside diameter of 168,3 mm and a wall thickness of 4,5 mm as specified in DIN 2448, made from TTSt 35 steel (material number 1.0356), in the quenched and tempered condition (V) shall be designated as follows:

Tube DIN 2448 — 168,3 X 4,5
DIN 17 173 — TTSt 35 V

or

Tube DIN 2448 — 168,3 X 4,5
DIN 17 173 — 1.0356 V

4.2 ● In addition to the standard designation as specified in subclause 4.1, the order shall always give the quantity required (e.g. total length to be supplied), the type of length (see table 5), the length of the individual tube in the case of specified lengths and exact lengths, the test class, the type of document on materials testing as specified in DIN 50 049 and the technical rule which may also be taken into consideration.

Example of an order:

1000 m of tube DIN 2448 — 168,3 X 4,5
DIN 17 173 — TTSt 35 V

in exact lengths of 8 m, test class 1,
document DIN 50 049 — 3.1 B

4.3 ●● In addition, further details such as are specified in the subclauses marked with two dots may be agreed at the time of ordering.

5 Requirements

5.1 Manufacturing process

5.1.1 The steels shall be produced by the basic oxygen process, by the open-hearth process, or in an electrical furnace. The process employed to make the steels used to manufacture the tubes complying with the require-

ments of this standard is left to the manufacturer's discretion. The purchaser shall be informed of the process selected.

A different, equivalent, process may also be employed, subject to agreement with the purchaser.

5.1.2 Steels TTSt 35 V, TTSt 35 N, 11 MnNi 5 3 and 13 MnNi 6 3 shall be specially killed (see table 1). Other steels complying with the requirements of this standard shall be fully killed.

5.1.3 ●● Unless otherwise agreed at the time of ordering, the process used to manufacture the tubes (e.g. hot or cold rolling, hot pressing, hot or cold drawing) is at the manufacturer's discretion.

5.2 As delivered condition

5.2.1 Table 3 shows the heat treatment condition in which the tubes shall be supplied.

5.2.2 ●● If the surfaces of the tubes are to be provided with an anti-corrosive agent with a limited life, this shall be agreed at the time of ordering.

5.3 Chemical composition

5.3.1 Cast analysis

The chemical composition of the steels determined in the cast analysis¹⁾ shall be as specified in table 1. Slight deviations from these values are permitted after consultation of, and agreement by the purchaser provided that the mechanical and technological properties of the tubes conform to this standard and weldability is not impaired.

5.3.2 Product analysis

When testing the finished tube, the permissible deviations shown in table 2, referring to the values specified in table 1, shall apply.

5.4 Mechanical properties

5.4.1 The yield stress, tensile strength and elongation after fracture of the tubes shall conform to the values specified in table 3. These shall apply for tubes in the as delivered condition specified in subclause 5.2.1 and for the test conditions described in clause 6. If, by way of departure from table 7, the order for tubes specifies a minimum wall thickness instead of a nominal wall thickness, the relevant minus tolerance given in table 7 is to be added to the thickness ordered before classifying the tubes according to the wall thickness ranges given in table 3.

5.4.2 Table 4 gives minimum values for the impact energy determined on ISO V-notch test pieces used to characterize the strength at low temperatures (see also footnote 2 to table 4).

5.4.3 The values shown in tables 3 and 4 shall also apply after any stress relieving for the further processing of the tubes as long as this is carried out in accordance with the data given in table 10. The total maximum holding time

¹⁾ When sequential castings are supplied, as is possible with continuously cast tubes, the term "cast" should be read as "casting unit".

Table 1. Chemical composition (cast analysis) of steels with low temperature toughness for seamless tubes

Steel grade		% by mass										
Symbol	Material number	C	Si _{max}	Mn	P _{max}	S _{max}	Al _{min}	Cr	Mo	Nb _{max}	Ni	V _{max}
TTSt 35 N TTSt 35 V	1.0356	max. 0,17	0,35	min. 0,40	0,030	0,025	0,020	-	-	-	-	-
26 CrMo 4	1.7219	0,22 to 0,29	0,35	0,50 to 0,80	0,030	0,025	-	0,90 to 1,20	0,15 to 0,30	-	-	-
11 MnNi 5 3	1.6212	max. 0,14	0,50	0,70 to 1,50	0,030	0,025	0,020	-	-	0,05	0,30 ¹⁾ to 0,80	0,05
13 MnNi 6 3	1.6217	max. 0,18	0,50	0,85 to 1,65	0,030	0,025	0,020	-	-	0,05	0,30 ¹⁾ to 0,85	0,05
10 Ni 14	1.5637	max. 0,15	0,35	0,30 to 0,80	0,025	0,020	-	-	-	-	3,25 to 3,75	0,05
12 Ni 19	1.5680	max. 0,15	0,35	0,30 to 0,80	0,025	0,020	-	-	-	-	4,50 to 5,30	0,05
X 8 Ni 9	1.5662	max. 0,10	0,35	0,30 to 0,80	0,025	0,020	-	-	max. 0,10	-	8,00 to 10,00	0,05

1) The lower limit value for the nickel content may be reduced to not less than 0,15 % by mass for tubes with wall thicknesses not exceeding 10 mm.

Table 2. Permissible deviations between the results of the chemical composition determined by the product analysis and the limiting values for the cast analysis

Element	Limiting values for the cast analysis as specified in table 1	Permissible deviations between the results of product analysis and the limiting values for the cast analysis ¹⁾
	% by mass	% by mass
C	≤ 0,29	0,02
Si	≤ 0,35 > 0,35 ≤ 0,50	0,03 0,05
Mn	≤ 0,80 > 0,80 ≤ 1,65	0,06 0,10
P	≤ 0,030	0,005
S	≤ 0,025	0,005
Al	≤ 0,020	0,005
Cr	≤ 1,20	0,10
Ni	≤ 0,85 > 0,85 ≤ 3,75 > 3,75 ≤ 5,30 ≤ 8,00 ≤ 10,00	0,05 0,07 0,10 0,15
Mo	≤ 0,10 > 0,10 ≤ 0,30	0,01 0,04
Nb	≤ 0,05	0,01
V	≤ 0,05	0,01

¹⁾ If several product analyses are carried out for a single cast and if these analyses show contents for a single element outside the range specified for the cast analysis, this content shall only either exceed the permissible maximum content or fall short of the permissible minimum content, but not both at the same time for one cast.

for multiple annealing shall be 150 minutes. An attempt should be made to keep to the lower limit of the temperature range where the holding time exceeds 90 minutes.

5.5 Technological properties

The tubes can be cold and hot formed (see table 10). They shall comply with the requirements to be verified in the technological tests specified in subclauses 6.5.3, and 6.5.4 and 6.5.5 as appropriate.

5.6 Weldability

5.6.1 Tubes made from the steel grades complying with this standard are weldable, if the generally recognized rules of the art are observed, steel grade 26 CrMo 4 being weldable only to a limited extent.

5.6.2 According to DIN 8528 Part 1 however, weldability is dependent not only on the steel grade but also on the conditions during welding, on the design and the operating conditions of the structural component.

●● It may be agreed at the time of ordering to restrict the residual magnetism of steels 12 Ni 19 and X 8 Ni 9 when supplied (see *DVS-Merkblatt* 1501).

5.7 Appearance of surface

5.7.1 The tubes shall have a smooth outside and inside surface consistent with the manufacturing process used.

5.7.2 Slight irregularities in the surface resulting from the manufacturing process, such as raised or depressed areas or shallow grooves are permitted as long as the remaining wall thickness fulfils the requirements specified in subclause 5.10.2.3 and the function of the tubes is not impaired (see also subclause 8.1).

5.7.3 Proper removal of surface defects using appropriate means (e.g. by grinding) is permitted as long as the remaining wall thickness fulfils the requirements of subclause 5.10.2.3. Stopping of surface defects is not permitted.

●● The tubes supplied may also have a particular surface condition (e.g. descaled), which has to be agreed upon at the time of ordering.

5.8 Leak tightness

The tubes shall remain leaktight when tested as specified in subclause 6.5.7.

5.9 Non-destructive testing

Test class 2 tubes shall comply with the requirements specified in *Stahl-Eisen-Prüfblatt* (Iron and steel test sheet) 1915 when subjected to non-destructive testing as described in subclause 6.5.9.

Table 3. Mechanical properties of the tubes in the as delivered condition¹⁾

Steel grade	Material number	Heat treatment condition 2)	Wall thickness s mm	Upper yield stress N/mm ² min	Tensile strength N/mm ²	Elongation after fracture ($L_{w1} = 5 d_w$)	
						longitudinal %	transverse %
TTSt 35 N	1.0356	N	$s \leq 10$	225	340 to 460	25	23
TTSt 35 V	1.0356	V	$s \leq 25$ $25 < s \leq 40$	255 235	360 to 490	23	21
26 CrMo 4	1.7219	V	$s \leq 25$ $25 < s \leq 40$	440 420	560 to 740	18	16
11 MnNi 5 3	1.6212	N ³⁾	$s \leq 13$ $13 < s \leq 25$ $25 < s \leq 40$	285 275 265	410 to 530	24	22
13 MnNi 6 3	1.6217	N ³⁾	$s \leq 13$ $13 < s \leq 25$ $25 < s \leq 40$	355 345 335	490 to 610	22	20
10 Ni 14	1.5637	V ⁴⁾	$s \leq 25$ $25 < s \leq 40$	345 335	470 to 640	20	18
12 Ni 19	1.5680	V ⁴⁾	$s \leq 25$ $25 < s \leq 40$	390 380	510 to 710	19	17
X 8 Ni 9	1.5662	V	$s \leq 25$ $25 < s \leq 40$	490 480	640 to 840	18	16

1) ●● The values for the mechanical properties of tubes with wall thicknesses greater than 40 mm, with the exception of steels TTSt 35 N and TTSt 35 V, shall be agreed at the time of ordering.

2) N = normalized; V = quenched and tempered.

3) Tempering can, occasionally, be necessary after normalizing. In this case, the manufacturer shall inform the purchaser, and shall indicate to him the tempering temperature.

4) If this is permitted by the dimensions, normalizing (N), with additional tempering as necessary, may be carried out at the manufacturer's discretion instead of quenching and tempering (V). The purchaser shall be informed if this is the case.

5.10 Dimensions, masses per unit length and permissible deviations

5.10.1 Dimensions

DIN 2448 shall apply for the outside diameter and wall thickness of tubes.

Table 5 shall apply for the types of tube length.

5.10.2 Permissible dimensional deviations

5.10.2.1 The information given in table 6 (see subclause 6.5.11) shall apply for the permissible deviations in outside diameter d_a .

●● For the tube ends, the lower permissible deviations in diameter given in table 6 may also be agreed.

5.10.2.2 The permissible minus deviation may, however, be slightly exceeded for a maximum tube length of 1 m at points where the surface of the tube has been repaired mechanically, for instance, because of defects found in non-destructive testing, as long as the conditions specified in subclause 5.10.2.3 are observed.

5.10.2.3 The permissible deviations in wall thickness are given in table 7.

5.10.2.4 ●● In special cases, by agreement at the time of ordering, tubes may be supplied in accordance with these technical delivery conditions with the permissible deviations in outside diameter and wall thickness as specified in DIN 2391 Part 1 or DIN 28 180.

5.10.2.5 The permissible deviations in length are given in table 5.

5.10.3 Permissible deviations of form

5.10.3.1 Circularity

The tubes shall be as circular as possible. The out-of-roundness shall be within the permissible deviations for the outside diameter.

5.10.3.2 Straightness

The tubes shall be straight to the eye.

●● Particular requirements regarding straightness may be agreed.

5.10.4 Finish of tube ends

The tube ends shall be cut perpendicular to the tube axis and shall be free from burr.

Table 4. Requirements relating to the impact energy in the impact test on ISO V-notch test pieces^{1), 2)}

Steel grade	Material number	Wall thickness <i>s</i> mm	Location of test pieces relative to tube axis	Minimum values of impact energy, in J ^{3), 4)} at test temperature, in °C										
				- 196	- 120	- 110	- 100	- 90	- 60	- 50	- 40	- 20	+ 20	
TTSt 35 N	1.0356	$s \leq 10$	Longitudinal									40	45	55
TTSt 35 V	1.0356	$s \leq 25$	Longitudinal Transverse ⁵⁾							40 27	45 30	50 35	60 40	
		$25 < s \leq 40$	Longitudinal Transverse ⁵⁾								40 27	45 30	55 35	
26 CrMo 4	1.7219	$s \leq 40$	Longitudinal Transverse ⁵⁾						40 27	40 27	45 30	50 35	60 40	
11 MnNi 5 3 13 MnNi 6 3	1.6212 1.6217	$s \leq 40$	Longitudinal Transverse ⁵⁾						40 27	45 30	50 35	55 40	70 45	
10 Ni 14	1.5637	$s \leq 25$	Longitudinal Transverse ⁵⁾				40 27	45 30	50 35	55 35	55 40	60 45	65 45	
		$25 < s \leq 40$	Longitudinal Transverse ⁵⁾					40 27	45 30	50 30	50 35	55 40	65 45	
12 Ni 19	1.5680	$s \leq 25$	Longitudinal Transverse ⁵⁾		40 27	45 30	50 30	55 35	65 45	65 45	65 45	70 50	70 50	
		$25 < s \leq 40$	Longitudinal Transverse ⁵⁾			40 27	45 30	50 30	60 40	65 45	65 45	65 45	70 50	
X 8 Ni 9	1.5662	$s \leq 40$	Longitudinal Transverse ⁵⁾	40 27	50 35	50 35	60 40	60 40	70 50	70 50	70 50	70 50	70 50	

¹⁾ ●● The values for tubes with wall thicknesses exceeding 40 mm, with the exception of steels TTSt35 N and TTSt35 V, shall be agreed at the time of ordering.
²⁾ The impact energy values shall each be determined for the lowest test temperature stated for the steel grade concerned; the values of impact energy at higher test temperatures shall be considered to have been demonstrated by the same determination.
³⁾ Average value from three test pieces, only one individual value may fall short of the specified minimum value by a maximum of 30 % (see also subclause 6.4.2).
⁴⁾ The values given in subclause 6.5.2 shall apply for wall thicknesses less than 10 mm.
⁵⁾ ●● To be determined only by agreement.

Table 5. Types of length and permissible deviations in length

Type of length	Permissible deviations in length, in mm	
Manufacturing length ¹⁾	1)	
Specified length	± 500	
Exact lengths	up to 6 m	+ 10 0
	over 6 m up to 12 m	+ 15 0
	over 12 m	By agreement.

¹⁾ The products are supplied in the manufacturing lengths occurring in production.
 ● The lengths differ according to the diameter, wall thickness and manufacturer's works and shall be agreed at the time of ordering.

Table 6. Permissible deviations in outside diameter

Outside diameter d_u mm	Permissible deviation in diameter	
	Tube barrel and tube ends	●● At tube ends, subject to particular agreement ¹⁾
$d_u \leq 100$	± 1% d_u (values up to ± 0,5 mm are permitted in all cases).	± 0,4 mm
$100 < d_u \leq 200$	± 1% d_u	± 0,5% d_u
$200 < d_u$	± 1% d_u	± 0,6% d_u ²⁾

¹⁾ Over a length of about 100 mm from the tube ends.
²⁾ ●● Subject to agreement at the time of ordering, the permissible deviation may also be referred to the inside diameter, in which case the permissible deviation in wall thickness is to be taken into account.

Table 7. Permissible deviations in wall thickness

Permissible deviation in wall thickness for outside diameters d_a								
$d_a \leq 130$ mm			130 mm < $d_a \leq 320$ mm and wall thicknesses s			320 mm < $d_a \leq 660$ mm		
$\leq 2 \cdot s_n$	$2 \cdot s_n < s \leq 4 \cdot s_n$	$> 4 \cdot s_n$	$\leq 0,05 d_a$	$0,05 d_a < s \leq 0,11 d_a$	$> 0,11 d_a$	$\leq 0,05 d_a$	$0,05 d_a < s \leq 0,09 d_a$	$> 0,09 d_a$
+ 15%	+ 12,5%	$\pm 9\%$	+ 17,5%	$\pm 12,5\%$	$\pm 10\%$	+ 22,5%	+ 15 %	+ 12,5%
- 10%	- 10 %		- 12,5%			- 12,5%	- 12,5%	- 10 %

Note. s_n is the standard wall thickness as specified in DIN 2448.

●● Subject to agreement, the tubes may be supplied with the joint faces prepared. In this case, the form of joint faces shall be specified.

5.10.5 Masses per unit length and permissible deviations

The values of masses per unit length of tubes are specified in DIN 2448. The following deviations from these values are permitted:

- + 12 % for a single tube;
- 8 %
- + 10 % for a batch of tubes not less than 10 t by mass.
- 5 %

6 Testing and documents on materials testing

6.1 General

Tubes complying with this standard shall be supplied with one of the following documents on materials testing as specified in DIN 50 049:

- document DIN 50 049 - 3.1 A (inspection certificate A);
- document DIN 50 049 - 3.1 B (inspection certificate B);
- document DIN 50 049 - 3.1 C (inspection certificate C).

● The type of document required and the test house where acceptance inspection is to be carried out by a third party shall be specified in the order.

6.2 Test site

The tubes shall be tested at the manufacturer's works. Production at the manufacturer's works shall not be unduly disturbed when acceptance inspection is carried out by experts who are not employees of the manufacturer.

6.3 Scope of test programme

6.3.1 The tubes shall be inspected by batches. Table 8 gives a synopsis of the scope of the test programme in each case.

For the purposes of testing, the tubes shall be divided up by steel grade, test class and dimensions and, if possible, also by casts, as a function of the outside diameter d_a , into batches each comprising the following numbers of tubes:

- for $d_a \leq 500$ mm, 100 tubes;
- for $d_a > 500$ mm, 50 tubes.

Remainders of up to 50 % of the batch quantity concerned may be distributed uniformly across the batches.

Remainders of more than 50 % and supplies of more than 10 tubes but not exceeding 50 tubes count as one complete batch.

If heat treatment is not carried out continuously, totals of up to 10 tubes with outside diameters d_a exceeding 500 mm count as one batch.

6.3.2 Two sample tubes shall be taken at the inspector's discretion from each of the two first batches (see subclause 6.3.1) and one sample tube from each further batch for the purposes of testing as specified in subclauses 6.5.1 to 6.5.5; sampling shall ensure that every cast is represented.

6.3.3 One sample tube shall be taken where supplies or batches are 10 tubes or less.

6.3.4 The following tests shall be carried out on the sample tubes:

- tensile test;
- impact test in the case of wall thicknesses not smaller than 5 mm;
- flattening test, ring expanding test or ring tensile test, as a function of the diameter and wall thickness of the tubes as shown in table 9.

6.3.5 ●● If it has been agreed at the time of ordering to verify the chemical composition (product analysis), this analysis shall be carried out on one tube per cast.

6.3.6 Furthermore,

6.3.6.1 all tubes shall be tested by the manufacturer's works for leak tightness, normally by means of a hydraulic test (see subclause 6.5.7). If, under the test conditions specified in subclause 6.5.7 (test pressure, 80 bar) a load limit of $0,7 \times R_{eH}$ (equivalent to a safety factor of about 1,5 against the yield stress) is not exceeded, then, at the manufacturer's discretion, instead of the hydraulic test a suitable non-destructive test method may be used for testing the leak tightness (for example an eddy current test as specified in *Stahl-Eisen-Prüfblatt* 1925).

6.3.6.2 all tubes made from alloy steels shall be subjected to a materials identity test by the manufacturer's works;

6.3.6.3 all tubes shall be inspected inside and outside for their surface appearance;

6.3.6.4 the tubes shall be inspected for their accuracy to size and permissible deviations as specified in subclause 5.10;

6.3.6.5 all test class 2 tubes shall be subjected to non-destructive testing (see subclause 6.5.9).

Table 8. Summary of the scope of test programme and documents on materials testing
(See figure 1 for sampling points and location of test pieces; see subclause 6.3.1 for batch size.)

Testing			Scope of test programme		Responsible for carrying out the tests	Type of document on materials testing
No.	Type of test	Subclause	Test class 1	Test class 2		
1	Cast analysis	5.3.1	Per cast or casting unit		Manufacturer	DIN 50 049 - 2.2 ¹⁾
2	Tensile test	6.4.1 6.5.1	On two sample tubes from the two first batches; from each further batch or from supplies of not more than 10 tubes, one test piece from one sample tube.		By agreement.	DIN 50 049 - 3.1A or DIN 50 049 - 3.1B or DIN 50 049 - 3.1C
3	Impact test	6.4.2 6.5.2	At one end of sample tube specified above (No. 2) for wall thicknesses ≥ 5 mm, one set of 3 test pieces.		By agreement.	DIN 50 049 - 3.1A or DIN 50 049 - 3.1B or DIN 50 049 - 3.1C
4	Flattening test, ring expanding test or ring tensile test (see table 9)	6.4.3 6.5.3 6.5.4 6.5.5	At one end of sample tube specified above (No. 2), one test piece for the flattening test or one test piece for the ring expanding test or one test piece for the ring tensile test.		By agreement.	DIN 50 049 - 3.1A or DIN 50 049 - 3.1B or DIN 50 049 - 3.1C
5	Leak tightness test	6.3.6.1 6.5.7	All tubes		Manufacturer	DIN 50 049 - 2.1 ¹⁾
6	Inspection of surface	6.5.8	All tubes		By agreement.	DIN 50 049 - 3.1A or DIN 50 049 - 3.1B or DIN 50 049 - 3.1C
7	Materials identity test	6.3.6.2	All alloy tubes		Manufacturer	DIN 50 049 - 2.1 ¹⁾
8	Non-destructive testing	6.5.9	-	All tubes	Manufacturer	DIN 50 049 - 3.1B
9	Check on dimensions	6.5.10 to 6.5.11	All tubes		By agreement.	DIN 50 049 - 3.1A or DIN 50 049 - 3.1B or DIN 50 049 - 3.1C
10	Product analysis ²⁾	6.4.4 6.5.6	By agreement.		Manufacturer	DIN 50 049 - 3.1B

¹⁾ This certificate may also be included in the next higher stage of document.
²⁾ The product analysis shall only be carried out if so agreed between the manufacturer and the purchaser.

Table 9. Tests to be carried out on annular test pieces, as a function of diameter and wall thickness of the tube

Diameter d mm		Wall thickness s , in mm		
outside	inside	< 2	$2 \leq s \leq 16$	$16 < s \leq 40$
≤ 21.3	≤ 15	Flattening test	Flattening test	-
$21.3 < d \leq 146$	> 15	Flattening test	Ring expanding test	Flattening test
> 146 ¹⁾			Ring tensile test	Ring tensile test ²⁾

¹⁾ This limit shall also apply for tubes ordered by inside diameter, if the outside diameter exceeds 146 mm.
²⁾ For tubes with inside diameters not exceeding 100 mm, the flattening test shall be carried out instead of the ring tensile test.

Table 10. Guideline values for hot forming and heat treatment^{1), 2)}

Steel grade		Hot forming ³⁾ °C	Normalizing °C	Tempering °C	Quenching and tempering			Stress relieving ⁴⁾ °C
Symbol	Material number				Hardening °C	Quenching in	Tempering °C	
TTSt 35 N	1.0356	1100 to 850	900 to 940	-	-	-	530 to 580	
TTSt 35 V			-	-	Water or oil	600 to 680		
26 CrMo 4	1.7219	1050 to 850	-	-	830 to 860	Water or oil	550 to 620 ⁵⁾	
11 MnNi 5 3	1.6212	1050 to 850	890 to 940	(580 to 640) ⁶⁾	-	-	520 to 560	
13 MnNi 6 3	1.6217	1050 to 850	890 to 940	(580 to 640) ⁶⁾	-	-	520 to 560	
10 Ni 14	1.5637	1100 to 850	830 to 880	580 to 640	820 to 880	Water or oil	520 to 560 ⁵⁾	
12 Ni 19	1.5680	1100 to 850	800 to 850	580 to 640	800 to 850	Water or oil	520 to 560 ⁵⁾	
X 8 Ni 9	1.5662	1050 to 850	880 to 930	-	770 to 820	Water or oil	- ⁸⁾	

1) The tubes shall reach the temperature throughout. If that is certain, then the holding time need not be extended in the case of normalizing and hardening.

2) The holding time for tempering and stress relieving shall be at least 30 minutes.

3) The temperature can fall to 750 °C during working. Shaping with a predominant proportion of upsetting can be carried out in the upper temperature range. Shaping processes in which stretching occurs, e.g. bending, should, on the other hand, be carried out in the lower temperature range. The shaping parameters shall, as a matter of principle, be harmonized with the process.

4) The information given by the manufacturer of the filler metals shall also be observed if stress relieving is carried out after welding.

5) The temperature should be approximately 30 K below the tempering temperature used; the tempering temperature shall not be exceeded in any event.

6) See footnote 3 to table 3.

7) Cooling after tempering shall be rapid (rate of cooling approximately 250 to 300 K/h to below 300 °C).

8) Stress relieving after welding shall be avoided.

6.4 Sampling and sample preparation

The information given in figure 1 shall apply for the sampling points and the test piece location.

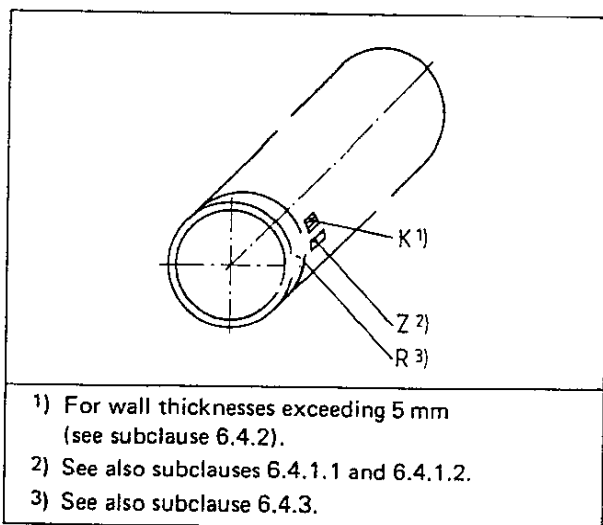

Figure 1. Sampling points and location of test pieces

In figure 1

K = set of 3 ISO V-notch test pieces as specified in DIN 50 115;

Z = tensile test piece (see subclause 6.4.1);

R = test piece for flattening test, ring expanding test or ring tensile test (see subclause 6.3.4 and table 9).

6.4.1 Tensile test

6.4.1.1 For the tensile test, one strip test piece (see DIN 50 140) shall be taken from the sample tube, longitudinal to the tube axis. The test piece shall not be heat treated and not straightened within the gauge length. At the manufacturer's discretion, tubes may also be subjected to the tensile test in full (see DIN 50 140).

6.4.1.2 Where the tubes have outside diameters not less than 200 mm, round or flat test pieces worked on all sides (see DIN 50 125) may be taken for the tensile test transverse to the tube axis, if the tube dimensions permit this without straightening.

6.4.1.3 As a rule, short proportional test pieces shall be taken for the tensile test.

In the case of test pieces which are not to be worked on all sides it is permitted to remove local irregularities but the rolling skin shall be retained at the thinnest area.

6.4.2 Impact test

For the impact test, a set of three ISO V-notch test pieces shall be taken from the sample tube transverse to the tube axis.

●● Test pieces shall only be taken transverse to the tube axis if agreed at the time of ordering, where the dimensions of the tube permit 10 mm wide test pieces to be taken without straightening.

If the wall thickness is not adequate for ISO V-notch test pieces, test pieces shall only be taken where wall thicknesses are not less than 5 mm if the width measured in the direction of the notch axis is at least 5 mm, but the remaining dimensions correspond to those of the normal V-notch test piece (see also subclause 6.5.2).

In the case of tubes the wall thickness of which exceeds 30 mm, the centre line of the test pieces shall have a distance from the external surface equal to one quarter of the wall thickness or shall be positioned as close as possible to this location.

The test pieces shall be taken and prepared in such a way that the axis of the notch is perpendicular to the tube surface.

6.4.3 Technological tests

The test piece for the flattening test as in DIN 50 136 or for the ring expanding test as in DIN 50 137 or for the ring tensile test as in DIN 50 138 shall be taken from one end of each sample tube (see table 9).

6.4.4 Chemical composition

For checking the chemical composition by a product analysis on the finished tube, sample chips shall be taken at points uniformly distributed over the entire wall thickness of the product; a similar procedure shall be used for spectral analyses. In general, *Stahl-Eisen-Prüfblatt* 1805 shall apply for sampling.

6.5 Test procedure

6.5.1 The tensile test shall be carried out as specified in DIN 50 140 or DIN 50 145.

6.5.2 The impact test shall be carried out as described in DIN 50 115.

The impact energy shall always be determined at the lowest test temperature specified for the steel grade and wall thickness in table 4.

The minimum values specified in table 4 shall apply for the average of three test pieces, and only one individual value may fall short of this specified minimum value by not more than 30%.

Where the width of test pieces is not equal to 10 mm (see subclause 6.4.2), the impact energy measured $A_{v,p}$ shall be stated along with the test piece cross section S_p . It can be converted to the impact energy A_v (in J) using the formula

$$A_v = \frac{8 \cdot 10 \cdot A_{v,p}}{S_p}$$

where

S_p is the cross section of the test piece under the notch, in mm².

6.5.3 The flattening test shall be carried out as specified in DIN 50 136, even in cases where the outside diameter exceeds 400 mm. The test pieces or tube ends shall be flattened until a specified distance between platens H is reached.

The following formula shall apply for the distance between platens H , in mm:

$$H = \frac{(1 + c) \cdot s}{c + s/d_n}$$

where

s is the wall thickness, in mm;

d_n is the outside diameter, in mm;

c is a constant having the following value:

0,09 for steel grades TTSt 35 N and TTSt 35 V;

0,07 for steel grades 11 MnNi 5 3, 13 MnNi 6 3 and 10 Ni 14;

0,06 for steel grades 26 CrMo 4, 12 Ni 19 and X 8 Ni 9.

If the ratio s/d_n exceeds a value of 0,15, c shall be reduced by 0,01 for the steel grades required.

6.5.4 The ring expanding test shall be carried out as specified in DIN 50 137; for this test, the change in diameter of the test piece when drifted until fracture shall also be measured. In addition, the ductility of the ring expanding test pieces shall be assessed on the basis of the appearance of the fracture and the fracture surfaces.

6.5.5 The ring tensile test shall be carried out as specified in DIN 50 138.

6.5.6 The chemical composition shall be determined in accordance with the methods specified by the Chemists' Committee of the *Verein Deutscher Eisenhüttenleute* (Society of German Ferrous Metallurgy Engineers) (see the "Standards and other documents referred to" clause).

6.5.7 For the hydraulic test (see also subclause 6.3.6.1) as specified in DIN 50 104, the test pressure shall be 80 bar.

6.5.7.1 ●● A higher test pressure may be agreed.

6.5.7.2 In no case however shall the safety margin with respect to the yield stress go below 1,1 (DIN 2413, June 1972 edition, subclause 4.6, $Y' = 0,9$ shall be complied with). Where appropriate, this shall also apply in the case of thin walled tubes with large outside diameters, even at 80 bar.

6.5.7.3 The test pressure shall be maintained for at least ten seconds.

6.5.8 The appearance of the tubes shall be examined visually under appropriate lighting conditions by an inspector having normal vision.

Note. Subject to agreement between manufacturer and purchaser, another suitable method of test may also be used instead of the visual examination.

6.5.9 The non-destructive testing of test class 2 tubes shall be carried out using the ultrasonic method specified in *Stahl-Eisen-Prüfblatt* 1915, or an equivalent method of test.

Non-destructive testing shall be carried out by the manufacturer.

●● Subject to prior agreement, the purchaser or a qualified inspector acting on his behalf may be present at the inspection.

6.5.10 The wall thicknesses shall be measured at the ends of the tube using suitable measuring instruments.

6.5.11 The diameter shall be measured using suitable measuring instruments as a two-point measurement.

6.6 Retests

6.6.1 Tubes not satisfying the requirements when tested as specified in subclauses 6.5.7 to 6.5.11 (leak tightness test, visual examination, non-destructive testing, check on dimensions) shall be rejected.

The manufacturer's works shall have the right to take suitable measures to correct defects or deviations found in these tests and to present these tubes for renewed acceptance inspection.

6.6.2 If one of the sample tubes fails the acceptance inspection including tensile test, impact test, flattening

test, ring expanding test or ring tensile test specified in subclauses 6.5.1 to 6.5.5, the manufacturer is justified in repeating the test giving unsatisfactory results on the same tube with twice the number of test pieces. All test pieces shall satisfy the requirements. If the requirements are still not satisfied in the new tests, the tube shall be rejected.

Two further tubes shall be taken from the batch concerned in place of the rejected sample tube and shall be submitted to the tests specified in subclauses 6.5.1 to 6.5.5.

If one of the requirements is still not fulfilled, the entire batch shall be considered not to comply with the standard. However, individual testing may be agreed between the parties concerned.

If the unsatisfactory result of testing can be improved by means of heat treatment or other suitable measures, the supplier shall be given the opportunity to present a batch which was rejected for renewed acceptance inspection. If the test pieces continue to fail to satisfy the requirements, the entire batch shall be considered not to comply with the standard.

6.6.3 Test results attributable to improperly carried out sampling, sample preparation or test procedure, or to an accidental and local defect in a test piece shall be deemed invalid.

6.7 Documents on materials testing

6.7.1 Depending on the agreement made at the time of ordering (see subclause 6.1), either document DIN 50 049—3.1 A (inspection certificate A), DIN 50 049—3.1 B (inspection certificate B) or DIN 50 049—3.1 C (inspection certificate C) shall be issued for tubes complying with this standard.

The type and scope of the tests, the responsibility for carrying out the tests and the type of documentation covering the tests are shown in table 8.

In each case, the technical rule agreed at the time of ordering shall be specified.

6.7.2 The documents shall state the marking of the tubes as specified in clause 7.

7 Marking

7.1 Every tube supplied in accordance with this standard shall be clearly and durably marked at one end, as follows:

- manufacturer's mark;
- an appended symbol S indicating that the tube is of the seamless type;
- appended symbol indicating test class (1 or 2);
- inspector's mark;
- inspector's mark indicating that test class 2 tubes have been tested non-destructively;
- tube number, number of tube under test or an equivalent identification number, e.g. number of test batch;
- ●● subject to agreement, tubes with outside diameters not less than 159 mm may be marked by the number of the cast.

7.2 Marking shall generally be applied by stamping. A different marking method (e.g. labelling the bundle of tubes) is also permitted for tubes with small outside diameters and/or small wall thicknesses.

their processing and use. This shall apply unless otherwise agreed at the time of ordering.

8 Complaints

8.1 Under current law, a complaint may only be raised against defective tubes if the defects noticeably impair

8.2 It is normal and practical for the purchaser to give the supplier the opportunity to judge whether the complaints are justified, if possible by submitting the tube objected to or samples of the tubes supplied.

Standards and other documents referred to

DIN 2391 Part 1	Seamless precision steel tubes; dimensions
DIN 2413	Steel pipes; calculation of wall thickness with regard to internal pressure
DIN 2448	Seamless steel tubes; dimensions, masses per unit length
DIN 8528 Part 1	Weldability; metallic materials; concepts
DIN 17 179	(at present at the stage of draft) Seamless circular fine grain steel tubes subject to special requirements; technical delivery conditions
DIN 17 458	(at present at the stage of draft) Seamless circular stainless austenitic steel tubes subject to special requirements; technical delivery conditions
DIN 28 180	(at present at the stage of draft) Seamless steel tubes for tubular heat exchangers
DIN 50 049	Documents on materials testing
DIN 50 104	Internal pressure test on hollow products; leak tightness test up to a defined internal pressure; general specifications
DIN 50 115	Testing of metallic materials; impact test
DIN 50 125	Testing of metallic materials; tensile test pieces; guidelines for their preparation
DIN 50 136	Testing of metallic materials; flattening test on tubes
DIN 50 137	Testing of metallic materials; ring expanding test on tubes
DIN 50 138	Testing of metallic materials; ring tensile test on tubes
DIN 50 140	Testing of metallic materials; tensile test on tubes and strips from tubes
DIN 50 145	Testing of metallic materials; tensile test
<i>Stahl-Eisen-Prüfblatt</i> 1805 2)	<i>Probenahme und Probenvorbereitung für die Stückanalyse bei Stählen</i> (Sampling and sample preparation for the product analysis of steels)
<i>Stahl-Eisen-Prüfblatt</i> 1915 2)	<i>Ultraschallprüfung auf Längsfehler von Rohren aus warmfesten Stählen</i> (Ultrasonic testing of creep-resisting steel tubes for longitudinal defects)
<i>Stahl-Eisen-Prüfblatt</i> 1925 2)	<i>Elektromagnetische Prüfung von Rohren zum Nachweis der Dichtheit</i> (Electromagnetic testing of tubes for leak tightness)
<i>Handbuch für das Eisenhüttenlaboratorium</i> 2)	(Handbook for the ferrous metallurgy laboratory); volume 2: <i>Die Untersuchung der metallischen Werkstoffe</i> (Investigation of metallic materials); Düsseldorf 1966; volume 5 (supplement): A 4.4 – <i>Aufstellung empfohlener Schiedsverfahren</i> (List of recommended arbitration procedures); B – <i>Probenahmeverfahren</i> (Sampling methods); C – <i>Analysenverfahren</i> (Methods of analysis); most recent edition in each case.
<i>AD-Merkblatt</i> W10	<i>Werkstoffe für tiefe Temperaturen; Eisenwerkstoffe</i> (Materials for use at low temperatures; ferrous materials); (obtainable from <i>Beuth Verlag GmbH</i> , Berlin).
<i>DVS-Merkblatt</i> 1501	<i>Empfehlungen für das Schweißen der kaltzähnen Nickelstähle 10 Ni 14, 12 Ni 19 und X 8 Ni 9</i> (Recommendations for welding nickel steels 10 Ni 14, 12 Ni 19 and X 8 Ni 9) (obtainable from <i>Deutscher Verlag für Schweißtechnik GmbH</i> , Krefeld).

2) Obtainable from: *Verlag Stahleisen mbH*, Düsseldorf.

Explanatory notes

This first edition of a DIN Standard for seamless circular tubes made from steels with low temperature toughness was developed from *Stahl-Eisen-Werkstoffblatt 680-70 Kaltzähe Stähle; Gütevorschriften* (Steels with low temperature toughness; quality specifications). Welded tubes and sheet, strip, wide flats, profiles, bars and forgings made from steel with low temperature toughness have been standardized in Standards DIN 17 174 and DIN 17 281 respectively which are being published at the same time. By comparison with *Stahl-Eisen-Werkstoffblatt 680-70*, these standards omit the stainless austenitic steels with low temperature toughness and also steels 14 Ni 6 and 16 Ni 14, whilst steels 11 MnNi 5 3 and 13 MnNi 6 3 have been included.

During the discussions on this standard, it was agreed that the lowest test temperatures for the impact test specified in table 4 may not, in any event, be equated with the lowest application temperatures. It was also agreed that the consumers should not experience any disadvantages in the application of the steels as a consequence of the transition from DVM test pieces to ISO V-notch test pieces; this is to be taken into consideration in the revision of *AD-Merkblatt W10 Werkstoffe für tiefe Temperaturen; Eisenwerkstoffe*.

This standard is related to ISO 2604/2 – 1975, "Steel products for pressure purposes; quality requirements; wrought seamless tubes", published by the International Organization for Standardization. ISO 2604/2 – 1975 only gives, to some extent, comparable grades (steel TS 6 and TS 45, respectively) for TTSt 35 and X 8 Ni 9. There are no grades in DIN 17 173 corresponding to the three other steel grades covered by ISO 2604/2 – 1975 (TS 10, TS 15 and TS 43).

International Patent Classification

F 16 L 9/02
G 01 N 3/08
G 01 N 3/48
G 22 C 38/08
G 01 N 3/28
G 01 N 29/04
G 01 N 19/08
G 01 N 27/82
G 01 M 3/00