

# Square and rectangular fine grain steel tubes (hollow sections) for structural steelwork

Technical delivery conditions

**DIN**  
17 125

Quadratische und rechteckige Rohre (Hohlprofile) aus Feinkornbaustählen für den Stahlbau; technische Lieferbedingungen

*In keeping with current practice in standards published by the International Organization for Standardization (ISO), a comma has been used throughout as the decimal marker.*

The subclauses marked with a single dot ● give specifications which are to be agreed upon at the time of ordering. The subclauses marked with two dots ●● give specifications which are optional and may be agreed upon at the time of ordering.

## Contents

	Page		Page
<b>1 Field of application</b> .....	1	<b>5.8 Dimensions, masses per unit length, permissible deviations</b> .....	3
<b>2 Concept</b> .....	1	<b>6 Testing and materials testing certificates</b> .....	5
<b>3 Classification into grades</b> .....	1	6.1 General .....	5
<b>4 Designation and ordering</b> .....	1	6.2 Test site .....	5
<b>5 Requirements</b> .....	1	6.3 Scope of test programme .....	5
5.1 Manufacturing process .....	1	6.4 Sampling and sample preparation .....	6
5.2 As delivered condition .....	2	6.5 Test procedure .....	7
5.3 Chemical composition .....	3	6.6 Retests .....	7
5.4 Mechanical properties .....	3	6.7 Materials testing certificates .....	7
5.5 Weldability .....	3	<b>7 Marking</b> .....	7
5.6 Heat treatment and further processing .....	3	<b>8 Complaints</b> .....	7
5.7 Appearance of surface .....	3		

### 1 Field of application

**1.1** This standard applies to seamless and welded square and rectangular tubes (hereinafter referred to as "hollow sections") made from the fine grain structural steels listed in table 1. These hollow sections are used in structural steelwork (as in building and civil engineering, tubular steel construction, bridge and crane construction, etc.). They are not intended to withstand internal or external pressures.

### 2 Concept

For the purposes of this standard, fine grain structural steels are steels with a minimum yield strength between 255 and 460 N/mm<sup>2</sup>, whose chemical composition is selected so as to ensure weldability, this being a function of the minimum yield strength. The steels are fully killed and contain elements forming precipitations, e.g. nitrides and/or carbonitrides. These prevent the growth of crystal grains in the austenite region and lead to fine grain in the as delivered condition (ferrite grain size 6 and finer when tested as described in DIN 50 601). Thus, the steels of this type are highly resistant to brittle fracture.

### 3 Classification into grades

This standard comprises three series of steel grades, as listed in table 1:

- a) the basic (StE...) series;
- b) the low temperature (TStE...) series including grades which are to have a minimum impact energy down to temperatures of -50°C (see table 4);

c) the special low temperature (EStE...) series including grades which are to have a minimum impact energy down to temperatures of -60°C (see table 4);

● The selection of the steel grade is at the purchaser's discretion.

### 4 Designation and ordering

**4.1** The specifications given in the dimensional standard (DIN 59 410 or DIN 59 411) shall apply for the standard designation of hollow sections.

**4.2** ● In addition to the standard designation, the order shall always give the quantity required (e.g. total length to be supplied), the type of length (see DIN 59 410 or DIN 59 411), the length of the individual hollow section in the case of specified lengths and exact lengths, the type of materials testing certificate as specified in DIN 50 049 or any additional relevant technical rule or code of practice (e.g. *DAST-Richtlinie* (DAST Code of practice) 011).

**4.3** ●● In addition, further details such as are specified in the subclauses marked with two dots may be agreed at the time of ordering.

### 5 Requirements

#### 5.1 Manufacturing process

**5.1.1** The steels shall be produced either by the basic oxygen process, the open hearth process or in the electric furnace.

**5.1.1.1** ●● Subject to agreement with the purchaser, an alternative equivalent process may also be used.

Continued on pages 2 to 9

5.1.1.2 ●● If so agreed, the purchaser shall be informed on the steelmaking process used.

5.1.2 The steels shall be fully killed, shall have sufficient elements for nitrogen control and shall be fine grained (see clause 2).

5.1.3 The process used to manufacture the hollow sections is left to the manufacturer's discretion.

5.1.3.1 Hollow sections complying with this standard shall generally be fabricated from seamless, pressure welded or fusion welded tubes, by hot or cold working followed by a normalizing process.

5.1.3.2 In the case of hollow sections made from welded tubes, a full penetration weld shall be produced.

In the case of hollow sections made from fusion welded tubes, the welds shall be made from both sides.

Hollow sections made from pressure welded tubes shall be supplied without external upset.

5.1.3.3 ●● Internal deburring may be agreed at the time of ordering.

5.1.3.4 Local repair of welds is permitted.

5.1.3.5 In the case of hollow sections made from welded tubes, the manufacturer's works shall have at its disposal the specialists and suitable equipment or processes to enable welding work to be properly carried out and inspected.

5.1.3.6 ●● The purchaser may, on one occasion only, request a document certifying compliance with the requirements specified in subclause 5.1.3.5. The details of this document<sup>1)</sup>, in particular with regard to the test house, shall be agreed between manufacturer and purchaser.

This document shall be considered valid only for the steel grades, dimensional ranges, welding processes and filler metals to which it refers.

5.2 As delivered condition

5.2.1 The hollow sections shall be supplied in the normalized condition.

Normalizing of the hollow sections may be dispensed if, in the case of steel grades having a minimum yield strength not exceeding 355 N/mm<sup>2</sup>, the final forming operation in production of hollow sections is normalizing forming, ensuring a condition equivalent to normalizing (see *Stahl-Eisen-Werkstoffblatt* (Iron and steel materials sheet) 082).

5.2.2 In the case of hollow sections with small wall thickness and made from steel grades having a minimum yield strength not less than 420 N/mm<sup>2</sup>, a delayed cooling or additional tempering may be required.

In the case of hollow sections with a wall thickness exceeding 50 mm or if the wall thickness/diameter ratio exceeds 0,15, an accelerated cooling after normalizing or liquid quenching and tempering is permitted.

5.2.3 ●● If the surface of hollow sections is to be provided with an anti-corrosive agent with a limited life, this shall be agreed at the time of ordering.

5.2.4 ●● If special requirements are made on hollow sections with regard to further processing (e.g. galvanizing), this shall be agreed at the time of ordering.

<sup>1)</sup> Steel structures as specified in DIN 18800 Part 7, subject to building inspectorate approval.

Table 1. Chemical composition as determined by the cast analysis

Steel grade		% by mass														
Symbol	Material number	C ≤	Si	Mn	P ≤	S ≤	N ≤	Al <sub>(tot)</sub> <sup>1)</sup> ≥	Cr ≤	Cu ≤	Mo ≤	Ni ≤	Nb ≤	Ti ≤	V ≤	Nb+Ti+V ≤
StE 255	1.0461	0,18	≤ 0,40	0,50	0,035	0,030	0,020	0,020	0,30 <sup>2)</sup>	0,20 <sup>2)</sup>	0,08 <sup>2)</sup>	0,30	0,03	-	-	0,05
TStE 255	1.0463	0,16		to	0,030	0,025										
EStE 255	1.1103	0,16		1,30	0,025	0,015										
StE 285	1.0486	0,18	0,10	0,60	0,035	0,030	0,020	0,020	0,30	0,20	0,08	0,30 <sup>4)</sup>	-	-	0,10	0,12
TStE 285	1.0488	0,16		to	0,030	0,025										
EStE 285	1.1104	0,16		1,40	0,025	0,015										
StE 355	1.0562	0,20	0,10	0,90	0,035	0,030	0,020	0,020	0,30	0,20 <sup>3)</sup>	0,10	1,00	0,05	- <sup>5)</sup>	0,20	0,22
TStE 355	1.0566	0,18		to	0,030	0,025										
EStE 355	1.1106	0,18		0,50	1,65	0,025										
StE 420	1.8902	0,20	0,10	1,00	0,035	0,030	0,020	0,020	0,30	0,20 <sup>3)</sup>	0,10	1,00	0,05	- <sup>5)</sup>	0,20	0,22
TStE 420	1.8912				0,030	0,025										
EStE 420	1.8913				0,025	0,015										
StE 460	1.8905	0,20	0,10	1,70	0,035	0,030	0,020	0,020	0,30	0,20 <sup>3)</sup>	0,10	1,00	0,05	- <sup>5)</sup>	0,20	0,22
TStE 460	1.8915				0,030	0,025										
EStE 460	1.8918				0,025	0,015										

<sup>1)</sup> If nitrogen is additionally controlled by niobium, titanium or vanadium, the requirement for a minimum aluminium content need not be complied with.  
<sup>2)</sup> The sum of the contents by mass of chromium, copper and molybdenum shall not exceed 0,45%.  
<sup>3)</sup> If copper is added as an alloying element, the maximum content by mass may be 0,70%.  
<sup>4)</sup> If nickel is added as an alloying element, the maximum content by mass may be 0,85%.  
<sup>5)</sup> If titanium is added as an alloying element, the maximum content by mass may be 0,20%.

### 5.3 Chemical composition

#### 5.3.1 Chemical composition as determined by the cast analysis

The chemical composition of the steels as determined by the case analysis<sup>2)</sup> is given in table 1.

The table specifies the permissible contents of the individual alloying elements. The manufacturer shall inform the purchaser on the types of alloying element used and on the associated percentages, for the steel grade supplied.

#### 5.3.2 ●● Chemical composition as determined by the product analysis

If checking of the chemical composition on the product has been agreed at the time of ordering, the results of the product analysis shall be allowed to deviate, by the amounts stated in table 2, from the limit values for the cast analysis to be notified by the manufacturer.

Table 2. Amounts by which the chemical composition as determined by the product analysis may deviate from the limit values to be stated by the manufacturer for the cast analysis (see subclause 5.3.2)

Element	Limit values specified for the cast analysis as in table 1	Permissible deviations of results of product analysis from the limit values as determined by the cast analysis <sup>1)</sup>
	% by mass	% by mass
C	≤ 0,20	0,02
Si	≤ 0,60	0,05
Mn	≤ 1,00	0,06
	> 1,00 ≤ 1,70	0,10
P	≤ 0,035	0,005
S	≤ 0,030	0,005
Cr	≤ 0,30	0,04
Cu	≤ 0,70	0,07
Mo	≤ 0,10	0,03
Ni	≤ 1,00	0,05
Nb	≤ 0,05	0,01
Ti	≤ 0,20	0,02
V	≤ 0,20	0,02
N	≤ 0,020	0,002

<sup>1)</sup> If several product analyses are carried out for a single cast and if these elements show contents for a single element outside the range specified for the cast analysis, this content shall either exceed the permissible maximum content or be below the permissible minimum content, but not both at the same time for one cast.

### 5.4 Mechanical properties

5.4.1 The values of yield stress, tensile strength, elongation after fracture and impact energy given in tables 3 and 4 for hollow sections with a wall thickness not exceeding 40 mm are based on the test conditions given in clause 6 and shall apply for the as delivered condition as specified in subclauses 5.2.1 and 5.2.2.

The minimum values of yield stress and tensile strength shall also apply for the weld.

5.4.2 ●● If hollow sections are subjected to stresses vertical to their axis, which will normally occur in the case of

<sup>2)</sup> When sequential castings are supplied, as is possible with continuously cast tubes, the term "cast" should be read as "casting unit".

wall thicknesses equal to or exceeding 20 mm, minimum values of reduction in area after fracture as laid down in *Stahl-Eisen-Lieferbedingungen* (Iron and steel delivery conditions) 096 may be agreed at the time of ordering.

5.4.3 For characterizing the susceptibility to brittle fracture, table 3 gives minimum values of impact energy determined on ISO standard test pieces taken in the longitudinal direction, at a test temperature of  $-20^{\circ}\text{C}$ .

5.4.3.1 ●● If the hollow section dimensions permit sampling without straightening of the hollow sections, minimum values of impact energy determined on ISO standard test pieces taken transverse to the hollow section axis or minimum values at test temperatures other than given in table 4 may also be agreed at the time of ordering.

### 5.5 Weldability

Hollow sections made from the steel grades complying with this standard are weldable, if the generally recognized rules of the art (see *Stahl-Eisen-Werkstoffblatt* 088) are observed.

### 5.6 Heat treatment and further processing

5.6.1 The temperatures for normalizing the steel grades are a function of their chemical composition.

Although the normalizing temperature may differ from one works to the next for one and the same steel grade (see subclause 5.3.1), it shall generally be between 880 and 960 °C.

5.6.2 Stress relieving shall be performed at temperatures between 530 and 580 °C, with cooling in still air. The holding period (as specified in DIN 17 014 Part 1) shall not exceed 150 minutes. Where the holding period exceeds 90 minutes, the lower limit of the temperature range shall be aimed at.

5.6.3 In the event of further processing of the hollow sections complying with this standard, the data specified in *Stahl-Eisen-Werkstoffblatt* 088 and in the certificate (see subclause 5.1.3.6) shall be observed.

### 5.7 Appearance of surface

5.7.1 Hollow sections shall have a smooth internal and external surface consistent with the manufacturing process.

5.7.2 Slight irregularities in the surface such as raised or depressed areas or shallow grooves resulting from the manufacturing process are permitted provided that the remaining wall thickness continues to meet the requirements specified in subclause 5.8.2.3, and the function of the hollow section is not impaired (see subclause 8.1).

5.7.3 Proper removal of shallow surface defects using appropriate means is permitted provided that the remaining wall thickness continues to meet the requirements specified in subclause 5.8.2.3. Stopping of surface defects is not permitted.

### 5.8 Dimensions, masses per unit length, permissible deviations

#### 5.8.1 Dimensions

DIN 59 410 or DIN 59 411 shall apply for the dimensions and types of length of hollow sections.

#### 5.8.2 Permissible dimensional deviations

5.8.2.1 The specifications given in DIN 59 410 or DIN 59 411 shall apply for the permissible deviations in side length of hollow sections.

Table 3. Mechanical properties of tubes with a wall thickness not exceeding 65 mm<sup>1)</sup>

Steel grade	Symbol	Material number	Minimum upper yield stress <sup>2)</sup> , $R_{eH}$ , for wall thicknesses, in mm, of					Tensile strength, $R_m$	Minimum elongation after fracture, $A_5$ , when testing test pieces taken		Minimum impact energy, $A_v$ <sup>4)</sup> (ISO standard test pieces taken in the longitudinal direction; test temperature: -20°C)
			$\leq 12$	$> 12$ $\leq 20$	$> 20$ $\leq 40$	$> 40$ $\leq 50$	$> 50$ $\leq 65$		N/mm <sup>2</sup>	parallel to the tube axis	
StE 255 TStE 255 EStE 255	1.0461 1.0463 1.1103		255	245	235	225	360 to 480 <sup>3)</sup>	25	23	39 47 65	
StE 285 TStE 285 EStE 285	1.0486 1.0488 1.1104		285	275	265	255	390 to 510 <sup>3)</sup>	24	22	39 47 65	
StE 355 TStE 355 EStE 355	1.0562 1.0566 1.1106		355	345	335	325	490 to 630 <sup>3)</sup>	22	20	39 47 65	
StE 420 TStE 420 EStE 420	1.8902 1.8912 1.8913		420	410	400	385	375	530 to 680	21	19	39 47 65
StE 460 TStE 460 EStE 460	1.8905 1.8915 1.8918		460	450	440	425	410	560 to 730	19	17	39 47 65

1) ● For wall thicknesses exceeding 65 mm, the values shall be agreed at the time of ordering.  
 2) If the yield stress cannot be easily recognized, the values shall apply for the 0,2% proof stress.  
 3) No objections shall be made if the upper limit is exceeded by up to 20 N/mm<sup>2</sup>.  
 4) ●● At the time of ordering, minimum values of impact energy determined on ISO standard test pieces taken transverse to the tube axis or minimum values at test temperatures other than given in table 4 may be agreed (see subclause 5.4.3.1).

Table 4. ●● Requirements regarding impact energy to be particularly agreed for Impact tests on ISO standard test pieces (see subclause 5.4.3.1)

Steel grades as in tables 1 and 3	Direction of sampling	Minimum values of impact energy, $A_v$ , for wall thicknesses, $s$ , from 10 to 65 mm at a test temperature, in °C, of								
		-60	-50	-40	-30	-20	-10	0	+10	+20
Basic series (StE...)	Longitudinal	-	-	-	-	39	43	47	51	55
	Transverse	-	-	-	-	21	24	31	31	31
Low temperature series (TStE...)	Longitudinal	-	27	31	39	47	51	55	59	63
	Transverse	-	16	20	24	27	31	31	35	39
Special low temper- ature series (EStE...)	Longitudinal	25	30	40	50	65	80	90	95	100
	Transverse	20 <sup>1)</sup>	27 <sup>1)</sup>	30 <sup>1)</sup>	35 <sup>1)</sup>	45 <sup>1)</sup>	60 <sup>1)</sup>	70 <sup>1)</sup>	75 <sup>1)</sup>	80 <sup>1)</sup>

1) Shall apply for wall thicknesses not exceeding 40mm. In the case of larger wall thicknesses, the values shall be agreed at the time of ordering.

**5.8.2.2** At points where the surface of hollow sections has been repaired by mechanical means, e.g. by grinding, the permissible minus deviation in side length may be exceeded provided that the requirements specified in subclause 5.8.2.3 are complied with.

**5.8.2.3** The specifications given in DIN 59410 or DIN 59411 shall apply for the permissible deviations from wall thickness,  $s$ , of hollow sections.

Misaligned weld edges in pressure welded hollow sections, where the reduction in cross section exceeds the permissible lower deviation in wall thickness, are not permitted.

**5.8.2.4** DIN 59410 or DIN 59411 specifies the permissible deviations in length.

### 5.8.3 Permissible deviations of form

The specifications given in DIN 59410 or DIN 59411 shall apply for the permissible deviations of form of hollow sections.

### 5.8.4 Permissible weld reinforcement

The weld reinforcement,  $\Delta a$ , as a function of the wall thickness,  $s$ , shall not exceed the following values:

a) for fusion welded hollow sections:

for  $s \leq 8$  mm,  $\Delta a \leq 2,5$  mm;

for  $s$  over 8 mm up to and including 14 mm,  
 $\Delta a \leq 3,0$  mm;

for  $s$  over 14 mm up to and including 40 mm,  
 $\Delta a \leq 4,0$  mm;

b) for pressure welded hollow sections:

After the upset has been removed, the inside weld reinforcement shall not exceed  $0,3$  mm +  $0,05 \times s$  ( $s$  given in mm) (see also subclause 5.1.3.2).

### 5.8.5 Finish of hollow section ends

The hollow section ends shall be cut perpendicular to the hollow section axis; the edges are not required to be deburred.

### 5.8.6 Masses per unit length

The masses per unit length shall comply with the values specified in DIN 59410 or DIN 59411.

## 6 Testing and materials testing certificates

### 6.1 General

Hollow sections complying with this standard may be supplied with one of the following materials testing certificates as specified in DIN 50049

- certificate DIN 50049 – 3.1 A (inspection certificate A);
- certificate DIN 50049 – 3.1 B (inspection certificate B);
- certificate DIN 50049 – 3.1 C (inspection certificate C).

● The type of certificate required and the test house where acceptance inspection is to be carried out by a third party shall be stated at the time of ordering.

### 6.2 Test site

Hollow sections shall be tested at the manufacturer's works. Production at the manufacturer's works shall not be unduly disturbed when acceptance inspection is carried out by experts who are not employees of the manufacturer.

### 6.3 Scope of test programme

Table 5 shows a summary of the scope of test programme in each case.

Table 5. Summary of the scope of test programme and materials testing certificates (see figure 1 for sampling points and location of test pieces; see subclause 6.3.1 for batch size)

No.	Testing Type of test	As in subclause	Scope of test programme	Responsibility for carrying out the tests	Type of materials testing certificate
1	Cast analysis	5.3.1	All characterizing elements per cast or casting unit.	Manufacturer	DIN 50049 – 2.2 <sup>1)</sup>
2	Tensile test	6.4.1 6.5.1	1 sample hollow section per batch, 1 test piece.	By agreement.	DIN 50049 – 3.1 A or DIN 50049 – 3.1 B or DIN 50049 – 3.1 C
3	Impact test	6.4.2 6.5.2	At one end of sample hollow section (No. 2) (for a wall thickness not less than 5 mm); 1 set of 3 test pieces.	By agreement.	DIN 50049 – 3.1 A or DIN 50049 – 3.1 B or DIN 50049 – 3.1 C
4	Surface inspection	6.5.4	All hollow sections.	By agreement.	DIN 50049 – 3.1 A or DIN 50049 – 3.1 B or DIN 50049 – 3.1 C
5	Check on dimensions	6.5.5 to 6.5.9	All hollow sections.	By agreement.	DIN 50049 – 3.1 A or DIN 50049 – 3.1 B or DIN 50049 – 3.1 C
6	Product analysis <sup>2)</sup>	6.4.3 6.5.3	By agreement.	Manufacturer	DIN 50049 – 3.1 B
7	Reduction in area after fracture <sup>3)</sup>	6.4.1.3	By agreement.	Manufacturer	DIN 50049 – 3.1 B

<sup>1)</sup> This certificate may also be included in the next higher stage of document.

<sup>2)</sup> The product analysis is only to be carried out subject to agreement between the manufacturer and purchaser.

<sup>3)</sup> This property is to be tested only subject to agreement between the manufacturer and purchaser on test pieces taken transverse to the tube axis.

**6.3.1** The hollow sections shall be inspected by batches. For the purposes of testing, the hollow sections shall be divided by steel grade and, where possible, by casts, dimensions and heat treatment units, into batches each comprising 100 units.

Remainders up to 50 units may be distributed uniformly across the other batches. Remainders over 50 units and consignments less than 50 units of a batch are to be considered a whole batch.

One hollow section (sample hollow section) shall be taken at the inspector's discretion from each batch for the tests to be carried out. The following tests shall be carried out on this sample hollow section:

- tensile test;
- impact test for wall thicknesses equal to or exceeding 5 mm;
- ●● product analysis, if this was agreed at the time of ordering.

**6.3.2** All hollow sections shall be inspected for surface appearance.

**6.3.3** All hollow sections shall be inspected for their accuracy to size and permissible deviations (see subclause 5.8).

#### 6.4 Sampling and sample preparation

See figure 1 for the sampling points and the location of test pieces.

##### 6.4.1 Tensile test

**6.4.1.1** For the tensile test, one flat test piece (short proportional test piece) as specified in DIN 50125 the thickness of which shall, as a rule, be equal to the wall thickness,

shall be taken in the longitudinal direction from the middle of one side. In the case of welded hollow sections, the test piece shall not include any part of the weld.

**6.4.1.2** The removal of local irregularities is permitted, the rolling skin shall however be retained at the thinnest spots.

**6.4.1.3** ●● If minimum values of reduction in area after fracture have been agreed at the time of ordering, testing shall be carried out on the basis of *Stahl-Eisen-Lieferbedingungen* 096, the scope of test programme being the subject of a particular agreement.

##### 6.4.2 Impact test

For the impact test, a set of three ISO standard test pieces shall be taken from the sample hollow section parallel to the axis, unless testing of test pieces taken transverse to the tube axis has been agreed at the time of ordering (see subclause 5.4.3.1). In the case of hollow sections with wall thicknesses exceeding 30 mm, the centre line of the test pieces shall have a distance from the hollow section external surface equal to one quarter of the wall thickness or shall be positioned as close as possible to this location.

The test pieces shall be taken and prepared in such a way that the notch axis is perpendicular to the hollow section surface.

If the wall thickness is inadequate for the manufacture of ISO standard test pieces, test pieces shall be taken whose width measured in the direction of the notch axis is equal to the wall thickness, but whose other dimensions correspond to those of ISO standard test pieces, in the case of wall thicknesses from 5 mm to 10 mm (see subclause 6.5.2). In this case, the values otherwise required decrease in direct proportion to the test piece cross section.

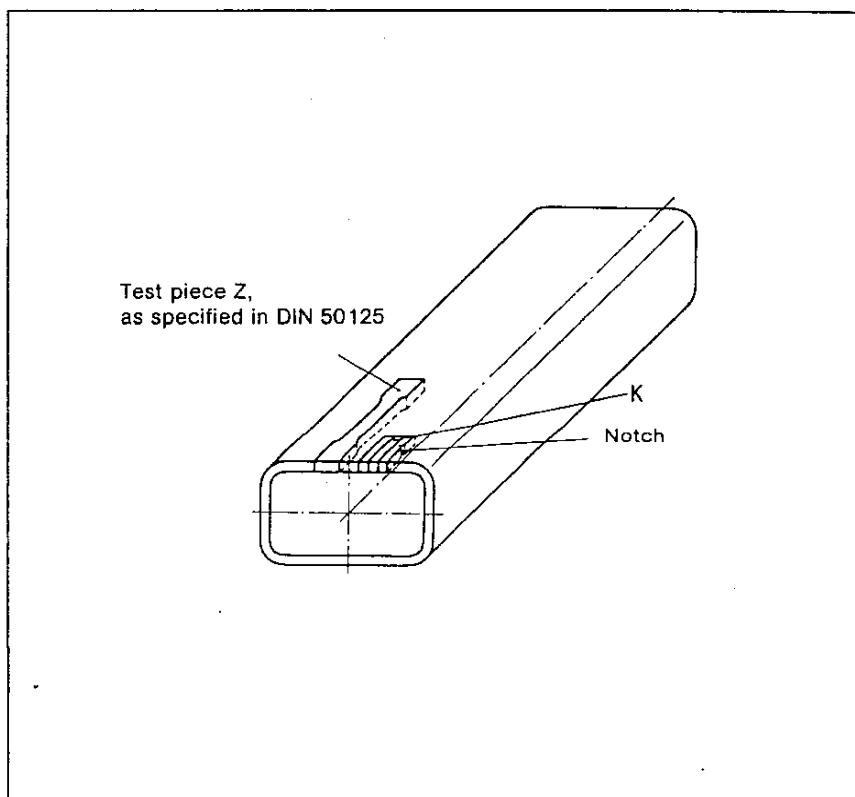

Figure 1. Sampling points and location of test pieces in the illustration.

K = set of 3 ISO standard test pieces as specified in DIN 50115;

Z = tensile test piece (see subclause 6.4.1).

### 6.4.3 Chemical composition

The sample chips required for checking the chemical composition shall be taken uniformly over the entire wall thickness of the product, the test being carried out as a product analysis on the finished hollow section; the procedure for spectral analysis shall be analogous. *Stahl-Eisen-Prüfblatt* (Iron and steel test sheet) 1805 shall normally apply for sampling.

### 6.5 Test procedure

**6.5.1** The tensile test shall be carried out in accordance with DIN 50 145.

**6.5.2** Unless otherwise agreed at the time of ordering (see subclause 5.4.3.1), the impact test shall be carried out as specified in DIN 50 115 at the test temperatures given in table 3. The specified minimum values shall apply for the mean obtained from three test pieces; only one individual value may be lower than this specified minimum value, yet by not more than 30%.

Where the width of test pieces is not equal to 10 mm (see subclause 6.4.2), the impact energy measured,  $A_{v,p}$ , shall be stated along with the test piece cross-sectional area. It can be converted to the impact energy,  $A_v$ , in J, using the following formula

$$A_v = \frac{8 \times 10 \times A_{v,p}}{S_p} \quad (1)$$

where

$S_p$  is the cross-sectional area of the test piece under the notch.

**6.5.3** The chemical composition shall be determined in accordance with the methods specified by the Chemists' Committee of the *Verein Deutscher Eisenhüttenleute* (Society of German Ferrous Metallurgy Engineers) (see the "Standards and other documents referred to" clause).

**6.5.4** The appearance of the hollow sections shall be examined visually under appropriate lighting conditions by an inspector having normal vision.

Note. Subject to agreement between manufacturer and purchaser, any other suitable method of test may be used instead of the visual examination.

**6.5.5** The wall thickness of hollow sections shall be measured outside the region of the permissible radius and outside the weld region, using suitable measuring instruments.

**6.5.6** The side lengths of hollow sections shall be measured, using suitable measuring instruments, as a two-point measurement.

**6.5.7** The deviation from straightness,  $q$  (see DIN 59 410 or DIN 59 411), shall be measured over the entire length of the hollow section.

**6.5.8** The twist,  $v$ , shall be measured as specified in DIN 59 410 or DIN 59 411. The measurement may be carried out at any point of the hollow section. During measurement, the hollow section shall be positioned horizontally, in the case of rectangular hollow sections lying on the long side of the cross section.

**6.5.9** In the case of hot formed hollow sections, the camber,  $t$ , shall be measured as specified in DIN 59 410 using suitable measuring instruments.

### 6.6 Retests

**6.6.1** Hollow sections not satisfying the requirements when tested as specified in subclauses 6.5.4 to 6.5.7 (visual examination, check on dimensions) shall be rejected.

The manufacturer's works shall have the right to take suitable measures to remedy defects or to correct deviations found in these tests and to present these hollow sections for renewed acceptance inspection.

**6.6.2** If one of the sample hollow sections fails the acceptance inspection including tensile test and impact test as specified in subclauses 6.5.1 and 6.5.2, the manufacturer is justified in repeating the test giving unsatisfactory results on the same hollow section with twice the number of test pieces. All test pieces shall satisfy the requirements. If the requirements are still not satisfied in the new tests, the hollow section shall be rejected.

Two further hollow sections shall be taken from the batch concerned in place of the rejected sample hollow section and shall be submitted to the tests specified in subclauses 6.5.1 and 6.5.2. If one of the requirements is still not fulfilled, the entire batch shall be considered not to comply with the standard. However, testing of hollow sections individually may be agreed between the parties concerned.

If the unsatisfactory result of testing can be improved by means of heat treatment or other suitable measures, the supplier shall be given the opportunity to present a batch which was rejected for renewed acceptance inspection. If the test pieces continue to fail to satisfy the requirements, the entire batch shall be considered not to comply with the standard.

**6.6.3** Test results attributable to improperly carried out sampling, sample preparation or test procedure, or to an accidental and local defect in a test piece shall be deemed invalid.

### 6.7 Materials testing certificates

Depending on the agreement made at the time of ordering (see subclause 6.1), either certificate DIN 50 049 – 3.1 A (inspection certificate A), DIN 50 049 – 3.1 B (inspection certificate B) or DIN 50 049 – 3.1 C (inspection certificate C) shall be issued for hollow sections complying with this standard. The type and scope of the tests, the responsibility for carrying out the tests and the type of certificate covering the tests are shown in table 5.

The certificates shall state how the hollow sections have been marked (see clause 7).

## 7 Marking

**7.1** Every hollow section supplied in accordance with this standard shall be clearly and durably marked at one end, as follows:

- manufacturer's symbol;
- symbol identifying the steel grade;
- inspector's mark.

**7.2** Marking shall generally be applied by stamping. A different marking method (e.g. labelling the bundle of hollow sections) is also permitted for hollow sections with small side lengths and/or a small wall thickness.

## 8 Complaints

**8.1** Under current law, a complaint may only be raised against defective hollow sections if the defects noticeably impair their processing and use. This shall apply unless otherwise agreed at the time of ordering.

**8.2** It is normal and practical for the purchaser to give the supplier the opportunity to judge whether the complaints are justified, if possible by submitting the hollow section objected to or samples of the hollow sections supplied.

**Standards and other documents referred to**

DIN 17 014 Part 1	Heat treatment of ferrous materials; terminology
DIN 18 800 Part 7	Steel structures; construction, verification of suitability for welding
DIN 50 049	Materials testing certificates
DIN 50 115	Testing of metallic materials; impact test
DIN 50 125	Testing of metallic materials; tensile test pieces
DIN 50 145	Testing of metallic materials; tensile test
DIN 50 601	Metallographic examination; determination of the ferritic or austenitic grain size of steel and ferrous materials
DIN 59 410	Steel sections for structural steelwork; hot formed square and rectangular steel tubes; dimensions, masses, permissible deviations, static values
DIN 59 411	Steel sections for structural steelwork; cold formed welded square and rectangular steel tubes; dimensions, masses, permissible deviations, static values
Stahl-Eisen-Werkstoffblatt 082 <sup>3)</sup>	<i>Begriffsbestimmung zur thermomechanischen Behandlung von Stahl</i> (Terminology associated with the thermo-mechanical treatment of steel)
Stahl-Eisen-Werkstoffblatt 088 <sup>3)</sup>	<i>Schweißgeeignete Feinkornbaustähle, Richtlinien für die Verarbeitung, besonders für das Schweißen</i> (Weldable fine grain structural steels; rules for processing, with special reference to welding)
Stahl-Eisen-Lieferbedingungen 096 <sup>3)</sup>	<i>Blech, Band und Breitflachstahl mit verbesserten Eigenschaften für Beanspruchungen senkrecht zur Erzeugnisoberfläche</i> (Plate, strip and wide flats with improved properties for stressing at right angles to the surface of the product)
Stahl-Eisen-Prüfblatt 1805 <sup>3)</sup>	<i>Probenahme und Probenvorbereitung für die Stückanalyse bei Stählen</i> (Sampling and sample preparation for the product analysis of steels)
Handbuch für das Eisenhüttenlaboratorium <sup>3)</sup>	(Handbook for the ferrous metallurgy laboratory);
	volume 2: <i>Die Untersuchung der metallischen Stoffe</i> (Investigation of metallic materials); Düsseldorf 1966;
	volume 5 (supplement):
	A 4.4 – <i>Aufstellung empfohlener Schiedsverfahren</i> (List of recommended arbitration procedures);
	B – <i>Probenahmeverfahren</i> (Sampling methods);
	C – <i>Analysenverfahren</i> (Methods of analysis);
	most recent edition in each case.
DAST Richtlinie 011 <sup>4)</sup>	<i>Hochfeste schweißgeeignete Feinkornbaustähle StE 460 und StE 690; Anwendung für Stahlbauten</i> (High-strength weldable fine grain structural steels StE 460 and StE 690 to be used for structural steelwork)

**Other relevant standards**

DIN 17 100	Steels for general structural purposes; quality standard
DIN 17 119	Welded cold formed square and rectangular steel tubes (hollow sections) for structural steelwork; technical delivery conditions
DIN 17 123	Welded circular fine grain steel tubes for structural steelwork; technical delivery conditions
DIN 17 124	Seamless fine grain steel tubes for structural steelwork; technical delivery conditions
EN 39	Steel tubes for working scaffolds; requirements, testing

<sup>3)</sup> Published by Verein Deutscher Eisenhüttenleute; obtainable from Verlag Stahleisen mbH, Postfach 82 29, D-4000 Düsseldorf 1.

<sup>4)</sup> Published by Deutscher Ausschuss für Stahlbau; obtainable from Stahlbau-Verlags-GmbH, Ebertplatz 1, D-5000 Köln 1.



## Explanatory notes

When *Stahl-Eisen-Werkstoffblatt 089-70 Schweißbare Feinkornbaustähle, Gütevorschriften* (Weldable fine grain structural steels; quality specifications) published by the *Verein Deutscher Eisenhüttenleute* (Society of German Ferrous Metallurgy Engineers) was adopted as Standard DIN 17 102, it was decided that DIN Standards were also to be prepared for weldable fine grain structural steel tubes and forgings. For the succinct presentation in the relevant specification and to facilitate their application, a total of 5 standards on weldable fine grain steel tubes have been prepared, classified according to manufacturing process (welded or seamless), use (for structural steelwork or subject to special requirements) and cross-sectional shape (circular or square and rectangular). This standard deals with welded and seamless square and rectangular tubes (hollow sections) for structural steelwork, whereas DIN 17 123 covers welded circular tubes and DIN 17 124 seamless circular tubes for structural steelwork.

The specifications for chemical composition, mechanical properties, etc. comply with those given in DIN 17 102. In the present standard, however, reflecting market demand, the steel grades are limited to the basic series, the low temperature series and the special low temperature series, and only the grades with a minimum yield strength of 255, 285, 355, 420 and 460 N/mm<sup>2</sup> have been included.

## International Patent Classification

E 04 B 1/42  
E 04 C 3/04  
E 04 C 3/32  
E 04 G 1/02  
E 04 H 12/08  
E 04 H 17/20  
E 01 D 9/00  
C 22 C 38/00  
G 01 N 3/00  
G 01 M 19/00