

Seamless circular steel tubes for structural steelwork

Technical delivery conditions

DIN
17 121

Nahtlose kreisförmige Rohre aus allgemeinen Baustählen für den Stahlbau; technische Lieferbedingungen

In keeping with current practice in standards published by the International Organization for Standardization (ISO), a comma has been used throughout as the decimal marker.

The subclauses marked with a single dot • give specifications which are to be agreed upon at the time of ordering.
The subclauses marked with two dots •• give specifications which are optional and may be agreed upon at the time of ordering.

Contents

| | Page | | Page |
|---|------|---|------|
| 1 Field of application | 1 | 5 Testing and documents | |
| 2 Classification into grades | 1 | on materials testing | 4 |
| 3 Designation and ordering | 1 | 5.1 General | 4 |
| 4 Requirements | 2 | 5.2 Test site | 4 |
| 4.1 Manufacturing process | 2 | 5.3 Scope of test programme | 5 |
| 4.2 As delivered condition | 2 | 5.4 Sampling and sample preparation | 5 |
| 4.3 Chemical composition | 2 | 5.5 Test procedure | 6 |
| 4.4 Mechanical properties | 2 | 5.6 Retests | 6 |
| 4.5 Weldability | 2 | 5.7 Documents on materials testing | 6 |
| 4.6 Appearance of surface | 3 | 6 Marking | 7 |
| 4.7 Dimensions, masses per unit length, permissible deviations | 3 | 7 Complaints | 7 |

1 Field of application

1.1 This standard applies to seamless circular tubes made from the steels listed in tables 1 and 2. These tubes are used in structural steelwork (as in building and civil engineering, tubular steel construction, bridge and crane construction, etc.).

1.2 This standard does not apply to

- a) — seamless circular unalloyed steel tubes subject to special requirements (see DIN 1629, at present at the stage of draft);
- high-performance seamless circular unalloyed steel tubes (see DIN 1630, at present at the stage of draft);
- seamless circular fine grain steel tubes for structural steelwork (see DIN 17 124, at present at the stage of draft);
- b) steel tubes for working scaffolds (see DIN EN 39).

2 Classification into grades

This standard covers tubes made from the steel grades listed in table 1.

- The selection of the steel grade is at the discretion of the purchaser.

3 Designation and ordering

3.1 The standard designation for tubes complying with this standard shall give in the following order:

- the term "tube";
- DIN number of the dimensional standard (DIN 2448);
- characteristic dimensions of the tube (outside diameter X wall thickness);
- number of DIN Standard giving the technical delivery conditions (DIN 17 121);
- symbol or material number identifying the steel grade (see tables 1 and 2).

Example:

A seamless tube conforming to this standard, with an outside diameter of 76,1 mm and a wall thickness of 2,9 mm as specified in DIN 2448, made from St 52-3 steel (material number 1.0570) shall be designated as follows:

Tube DIN 2448 — 76,1 X 2,9
DIN 17 121 — St 52-3

or Tube DIN 2448 — 76,1 X 2,9
DIN 17 121 — 1.0570

Continued on pages 2 to 8

3.2 ● In addition to the standard designation as specified in subclause 3.1, the order shall always give the quantity required (e.g. total length to be supplied), the type of length (see table 3), the length of the individual tubes in the case of specified lengths and exact lengths and the type of document on materials testing as specified in DIN 50 049.

Example of an order:

1000 m of tube DIN 2448 – 76,1 X 2,9
DIN 17 121 – St 52-3
in specified lengths of 8 m,
document DIN 50 049 – 3.1 B

3.3 ●● In addition, further details such as are specified in the subclauses marked with two dots may be agreed at the time of ordering.

4 Requirements

4.1 Manufacturing process

4.1.1 The process employed for making the steels used to manufacture the tubes conforming to this standard remains at the manufacturer's discretion.

The type of deoxidation of the steels shall be as specified in table 1.

●● If agreed, the purchaser shall be informed of the steelmaking process used.

4.1.2 Tubes complying with this standard shall be manufactured by hot rolling, hot pressing, hot or cold drawing. The process used to manufacture the tubes is left to the manufacturer's discretion.

4.2 As delivered condition

4.2.1 Tubes manufactured by hot forming shall be supplied in the hot formed condition. If necessary, normalizing shall be carried out in order to achieve the mechanical properties specified in table 2.

●● If this normalizing is desired as a matter of principle this shall be agreed at the time of ordering.
Cold rolled or cold drawn tubes shall be normalized and supplied in this condition.

4.2.2 ●● If the surfaces of the tubes are to be provided with an anti-corrosive agent with a limited life this shall be agreed at the time of ordering.

4.2.3 ●● If special requirements are made on the tubes (e.g. with regard to galvanizing) this shall be agreed at the time of ordering.

4.3 Chemical composition

The values specified in table 1 shall apply for the chemical composition of the steels (cast analysis¹⁾ and product analysis) (the values are in accordance with the specifications for the corresponding steel grades given in DIN 17 100). Slight deviations from the values stated are permitted if the mechanical properties of the tube conform to the present standard and weldability is not impaired.

4.4 Mechanical properties

The values listed in table 2 and obtained under the test conditions specified in clause 5 shall apply for the yield stress, tensile strength, elongation after fracture and impact energy of the tubes in the as delivered condition.

4.5 Weldability

Tubes made from the steel grades specified in this standard are suitable for gas fusion welding, arc welding and flash butt welding, they are also suitable for the electrical and gas pressure welding processes.

1) The term "cast" should be read as "casting unit" where a sequence cast is supplied as is possible where continuous casting processes are used.

Table 1. Chemical composition of steels for seamless circular tubes for use in structural steelwork

●● The values of wall thickness exceeding 65 mm shall be agreed at the time of ordering.

| Steel grade | | Type of de-oxidation ¹⁾ | Chemical composition, % by mass | | | | | | | | |
|-----------------------|-----------------|------------------------------------|---------------------------------|-------|-------|-----------------|---|------------------|-------|-------|-----------------|
| | | | Cast analysis | | | | Addition of nitrogen fixing elements (e.g. not less than 0,020 % A _(total)) | Product analysis | | | |
| | | | C | P | S | N ²⁾ | | C | P | S | N ²⁾ |
| Symbol | Material number | | max. | | | | | max. | | | |
| RSt 37-2 | 1.0038 | R | 0,17 | 0,050 | 0,050 | 0,009 | – | 0,19 | 0,060 | 0,060 | 0,010 |
| St 37-3 | 1.0116 | RR | 0,17 | 0,040 | 0,040 | – | Yes | 0,19 | 0,050 | 0,050 | – |
| St 44-2 | 1.0044 | R | 0,21 | 0,050 | 0,050 | 0,009 | – | 0,24 | 0,060 | 0,060 | 0,010 |
| St 44-3 | 1.0144 | RR | 0,20 | 0,040 | 0,040 | – | Yes | 0,23 | 0,050 | 0,050 | – |
| St 52-3 ³⁾ | 1.0570 | RR | 0,22 | 0,040 | 0,040 | – | Yes | 0,24 | 0,050 | 0,050 | – |

1) R killed (including semi-killed), RR fully killed.

2) A content in excess of the maximum value stated is permitted if a phosphorous content less than the maximum specified by 0,005 % P per 0,001 % N is observed. The nitrogen content shall not, however, exceed a value of 0,012 % N in the cast analysis and 0,014 % N in the product analysis.

3) The content shall not exceed 0,55 % Si and 1,60 % Mn in the cast analysis or 0,60 % Si and 1,70 % Mn in the product analysis.

Table 2. Mechanical properties of seamless circular tubes for structural steelwork

•• The values of wall thickness exceeding 65 mm shall be agreed at the time of ordering.

| Steel grade | Material number | Upper yield stress R_{eH} ¹⁾ for wall thicknesses, in mm, | | | Tensile strength R_m | Elongation after fracture A_5 | | Impact energy A_V ²⁾ (ISO V-notch longitudinal test pieces) | |
|-------------|-----------------|---|---------------------|---------------------|---------------------------|---------------------------------------|-------------------|--|---------------------------|
| | | ≤ 16 | > 16 ≤ 40 | > 40 ≤ 65 | | N/mm ² | longi- tudinal | trans- verse | Test temperature °C |
| Symbol | | N/mm ² | | | N/mm ² | % | | | |
| | | min. | | | | min. | | | min. |
| RSt 37-2 | 1.0038 | 235 | 225 | 215 | 340 to 470 | 26 | 24 | + 20 | 27 |
| St 37-3 | 1.0116 | 235 | 225 | 215 | 340 to 470 | 26 | 24 | - 20 | 27 |
| St 44-2 | 1.0044 | 275 | 265 | 255 | 410 to 540 | 22 | 20 | + 20 | 27 |
| St 44-3 | 1.0144 | 275 | 265 | 255 | 410 to 540 | 22 | 20 | - 20 | 27 |
| St 52-3 | 1.0570 | 355 | 345 | 335 | 490 to 630 | 22 | 20 | - 20 | 27 |

1) If the yield stress is not marked, the 0,2% proof stress ($R_{p0,2}$) shall be determined.
2) Average value from three tests; only one individual value may fall short of the minimum average value of 27 J, and this by not more than 30%. See subclause 5.4.2 and subclause 5.5.2 for narrower test pieces.

However, as specified in DIN 8528 Part 1, weldability does not only depend on the steel grade, but also on the conditions under which welding is carried out, on the design and on the operating conditions of the structural component.

4.6 Appearance of surface

4.6.1 The tubes shall have a smooth internal and external surface consistent with the manufacturing process.

4.6.2 Slight irregularities in the surface such as raised or depressed areas or shallow grooves resulting from the manufacturing process are permitted as long as the remaining wall thickness fulfils the requirements specified in subclause 4.7.2.2 and the function of the tube is not impaired (see also subclause 7.1).

4.6.3 Proper removal of shallow surface defects using appropriate means is permitted so long as the remaining wall thickness fulfils the requirements specified in subclause 4.7.2.2. Stopping of surface defects is not permitted.

4.7 Dimensions, masses per unit length, permissible deviations

4.7.1 Dimensions

DIN 2448 shall apply for the outside diameter and wall thickness of the tubes.

•• If agreed at the time of ordering tubes with different nominal dimensions may also be supplied.

Table 3 shall apply for the types of length.

4.7.2 Permissible dimensional deviations

4.7.2.1 The permissible deviations in the outside diameter d_a shall be $\pm 1\%$ (but $\pm 0,5$ mm is permitted).

•• By agreement at the time of ordering, the permissible deviation specified for tube outside diameter d_a exceeding 200 mm may also be related to the internal diameter, taking the permissible deviation in wall thickness into consideration.

At points where the surface of the tube has been repaired by mechanical means, e.g. by grinding, the diameter may

fall slightly short of the permissible minus deviation provided that the permissible minimum wall thickness is observed.

4.7.2.2 The permissible deviations in wall thickness s are given in table 4.

4.7.2.3 The permissible deviations in length are given in table 3.

4.7.3 Permissible deviations of form

4.7.3.1 Circularity

The tubes shall be as circular as possible. The out-of-roundness R shall be within the permissible deviations specified for the outside diameter.

4.7.3.2 Straightness

The tubes shall be straight to the eye. In cases of dispute, the deviation from straightness shall be not more than $0,002 \times l$ (l is the tube length).

•• Particular requirements on straightness may be agreed.

Table 3. Types of length and permissible deviations in length

| Type of length | Permissible deviations mm | |
|---|------------------------------|--------------|
| Manufacturing length ¹⁾ | 1) | |
| Specified length | ± 500 | |
| Exact length | up to 6 m | + 10 0 |
| | over 6 up to 12 m | + 15 0 |
| | over 12 m | By agreement |
| 1) The products are supplied in the manufacturing lengths occurring in production. • The lengths differ according to the diameter, wall thickness and manufacturer's works and shall be agreed at the time of ordering. | | |

Table 4. Permissible deviations in wall thickness

| Permissible deviations in wall thickness for outside diameter d_a and wall thickness s | | | | | | | | |
|--|------------------------------------|-----------------|------------------------------------|------------------------------|--------------|------------------------------------|------------------------------|--------------------|
| $d_a \leq 130$ mm | | | $130 \text{ mm} < d_a \leq 320$ mm | | | $320 \text{ mm} < d_a \leq 660$ mm | | |
| $\leq 2 \cdot s_n$ | $2 \cdot s_n < s \leq 4 \cdot s_n$ | $> 4 \cdot s_n$ | $\leq 0,05 d_a$ | $0,05 d_a < s \leq 0,11 d_a$ | $> 0,11 d_a$ | $\leq 0,05 d_a$ | $0,05 d_a < s \leq 0,09 d_a$ | $> 0,09 d_a$ |
| + 15 % - 10 % | + 12,5 % - 10 % | ± 9 % | + 17,5 % - 12,5 % | $\pm 12,5$ % | ± 10 % | + 20 % - 15 % | + 15 % - 12,5 % | + 12,5 % - 10 % |
| Note. s_n is the normal wall thickness as specified in DIN 2448. | | | | | | | | |

Table 5. Summary of the scope of test programme and documents on materials testing required for tubes supplied with inspection certificate; see figure 1 for sampling points and location of test pieces; see subclause 5.3.2 for batch size

| No. | Testing Type of test | As in subclause | Scope of test programme | Responsibility for carrying out the tests | Type of document on materials testing |
|--|--------------------------------|----------------------|--|---|---|
| 1 | Tensile test | 5.4.1 5.5.1 | 1 sample tube per batch, 1 test piece | By agreement | DIN 50 049 – 3.1 B or DIN 50 049 – 3.1 C |
| 2 | Impact test | 5.4.2 5.5.2 | At one end of sample tube specified above (No. 1) (for a wall thickness ≥ 5 mm); 1 set of 3 separate test pieces | By agreement | DIN 50 049 – 3.1 B or DIN 50 049 – 3.1 C |
| 3 | Inspection of surface | 5.5.4 | All tubes | By agreement | DIN 50 049 – 3.1 B or DIN 50 049 – 3.1 C |
| 4 | Check on dimensions | 5.5.5 to 5.5.7 | All tubes | By agreement | DIN 50 049 – 3.1 B or DIN 50 049 – 3.1 C |
| 5 | Product analysis ¹⁾ | 5.4.3 5.5.3 | By agreement | Manufacturer | DIN 50 049 – 3.1 B |
| 1) The product analysis is only to be carried out subject to agreement between the manufacturer and purchaser. | | | | | |

4.7.4 Finish of tube ends

The tube ends shall be cut perpendicular to the tube axis; they are not normally deburred.

- Deburring may be agreed at the time of ordering.

4.7.5 Masses per unit length and permissible deviations

DIN 2448 specifies the values of the mass per unit length for tubes, the calculation of the mass of tubes in non-standard lengths being based on a density of 7,85 kg/dm³. The following deviations from these values are permitted:

+ 12 % for an individual tube,
– 8 %

+ 10 % for a batch of tubes not less than 10 t by mass.
– 5 %

5 Testing and documents on materials testing

5.1 General

Tubes complying with this standard may be supplied with one of the following documents on materials testing as specified in DIN 50049:

a) tubes made from quality group 2 steels

- document DIN 50 049 – 2.2 (test report);
- document DIN 50 049 – 3.1 B (inspection certificate B);
- document DIN 50 049 – 3.1 C (inspection certificate C);

b) tubes made from quality group 3 steels

- document DIN 50 049 – 3.1 B (inspection certificate B);
- document DIN 50 049 – 3.1 C (inspection certificate C).

- The type of document required and the test house being considered where acceptance inspection is to be carried out by a third party shall be stated at the time of ordering.

5.2 Test site

The tubes shall be tested at the manufacturer's works. Production at the manufacturer's works shall not be

unduly disturbed when acceptance inspection is carried out by experts who are not employees of the manufacturer.

5.3 Scope of test programme

5.3.1 The values obtained for the yield stress, tensile strength and elongation after fracture listed in table 2, and compliance with the requirements specified in subclauses 5.3.3.1 and 5.3.3.2 shall be confirmed on the basis of continuous internal control in the case of tubes supplied with a test report.

5.3.2 If, subject to agreement, the tubes supplied are to be accompanied by an inspection certificate, they shall be inspected by batches. Table 5 shows a summary of the scope of test programme in each case.

For the purposes of testing, the tubes shall be divided up by steel grade and, where possible, by dimensions as a function of the outside diameter d_a , into batches each comprising the following numbers of tubes:

for $d_a \leq 100$ mm, 300 tubes;

for d_a above 100 mm up to and including 250 mm, 200 tubes;

for d_a above 250 mm up to and including 500 mm, 150 tubes;

for $d_a > 500$ mm, 100 tubes.

Remainders up to 50% of the batches may be distributed uniformly across the batches. Numbers of tubes and remainders over 50% and supplies less than 50% of a batch are to be considered to be a whole batch.

One tube (sample tube) shall be taken at the inspector's discretion from each batch for the tests to be carried out. The following tests shall be carried out on this sample tube:

- tensile test;
- impact test for wall thicknesses equal to or exceeding 5 mm;
- ●● product analysis, if this was agreed at the time of ordering.

5.3.3 Whatever the type of document on materials testing,

5.3.3.1 all tubes shall be inspected for surface appearance,

5.3.3.2 the tubes shall be inspected for their accuracy to size and deviations (see subclause 4.7).

5.4 Sampling and sample preparation

The information given in figure 1 shall apply for the sampling point and the test piece location.

5.4.1 Tensile test

5.4.1.1 For the tensile test, one strip test piece (see DIN 50 140) shall be taken from the sample tube, longitudinal to the tube axis. The test piece shall not be heat treated and shall not be straightened within the gauge length. At the manufacturer's discretion, tubes may also be subjected to the tensile test in full (see DIN 50 140).

In the case of wall thicknesses greater than 30 mm, at the manufacturer's discretion, circular test pieces (see

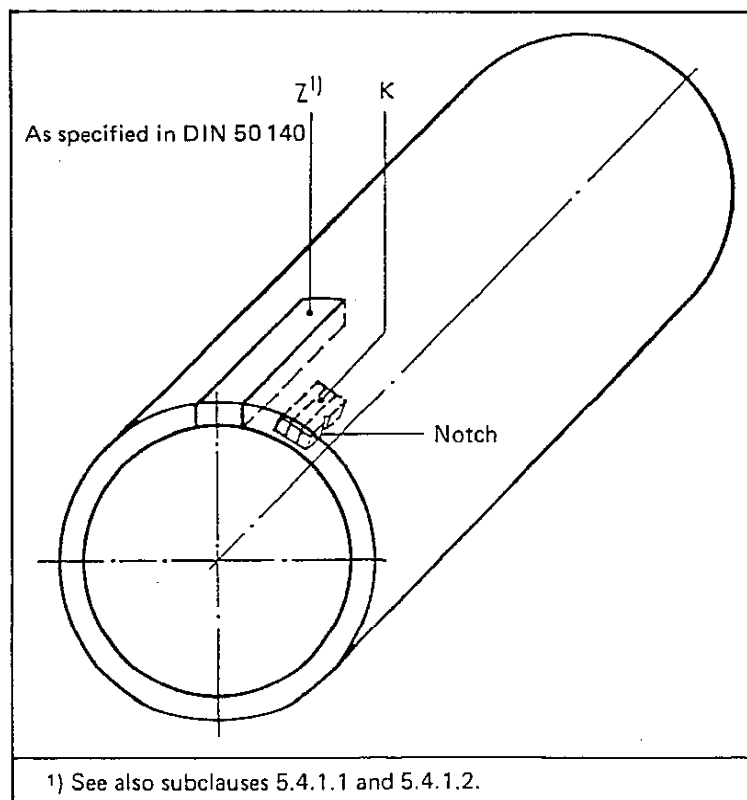

Figure 1. Sampling points and test piece location

In the illustration

K = set of 3 ISO V-notch test pieces as specified in DIN 50 115;

Z = tensile test piece (see subclause 5.4.1).

DIN 50 125) may be taken longitudinal to the tube axis, at a distance of 1/4 of the wall thickness from the outside surface or as close as possible to this point.

5.4.1.2 In the case of tubes with outside diameters greater than 200 mm, round or flat test pieces worked on all sides, may be taken transverse to the tube axis (see DIN 50 125), provided that the tube dimensions permit this procedure for an unstraightened tube.

5.4.1.3 Short proportional test pieces shall normally be taken for the tensile test. The removal of local irregularities from test pieces which have not been worked on all sides is permitted, but the rolling skin shall be retained at the thinnest spots.

5.4.2 Impact test

For the purposes of the impact test, a set of three ISO V-notch test pieces shall be taken from the test tube longitudinal to the tube axis. The test pieces shall be taken and prepared in such a way that the notch axis lies perpendicular to the tube surface.

If the wall thickness is not adequate for the manufacture of normal ISO V-notch test pieces, test pieces, the thickness measured in the direction of the notch axis of which is equal to the wall thickness, but the other dimensions of which correspond to that of the normal V-notch test piece, shall be taken in the case of wall thicknesses s from 5 mm to 10 mm (see also subclause 5.5.2).

5.4.3 Chemical composition

The sample chips required for checking the chemical composition shall be taken uniformly over the entire thickness of the product, the test being carried out as a product analysis on the finished tube; the procedure for spectral analysis shall be analogous. *Stahl-Eisen-Prüfblatt* (Iron and steel test sheet) 1805 shall normally apply for sampling.

5.5 Test procedure

5.5.1 The tensile test shall be carried out in accordance with DIN 50 145 or DIN 50 140.

5.5.2 The impact test shall be carried out as specified in DIN 50 115 at the test temperatures specified in table 2. The measured impact energy $A_{v,p}$ shall be stated, together with the test piece cross section S_p , in the case of test pieces, the width of which does not correspond to the standard width of 10 mm (see the last paragraph of subclause 5.4.2). The measured impact energy $A_{v,p}$ can be converted to the impact energy A_v , in J, using the formula

$$A_v = \frac{8 \cdot 10 \cdot A_{v,p}}{S_p}$$

(S_p is the cross section of the test piece below the notch, in mm²).

5.5.3 The chemical composition shall be determined according to the methods specified by the Chemists' Committee of the *Verein Deutscher Eisenhüttenleute* (Society of German Ferrous Metallurgy Engineers) (see the "Standards and other documents referred to" clause).

5.5.4 The appearance of the tubes shall be examined visually with normal vision under appropriate lighting conditions.

Note. A demonstrably suitable non-destructive method of test may also be used instead of the visual examination.

5.5.5 The wall thicknesses shall be measured at the end of the tubes using suitable measuring instruments.

5.5.6 The diameter shall be measured using appropriate measuring instruments as a two-point measurement or measurement of circumference. Measurement of circumference is to be used for tubes with an outside diameter greater than 500 mm.

5.5.7 For determining the circularity, a two-point measurement in one cross-sectional plane shall be made.

5.6 Retests

5.6.1 Tubes not satisfying the requirements when tested as specified in subclauses 5.5.4 to 5.5.7 (examination, check on dimensions) shall be rejected.

The manufacturer's works has the right to correct defects or deviations established in these tests by means of appropriate measures and then to present these tubes again for acceptance inspection.

5.6.2 If one of the sample tubes fails the acceptance inspection including tensile test and impact test as specified in subclauses 5.5.1 and 5.5.2, the manufacturer is justified in repeating the test giving unsatisfactory results on the same tube with twice the number of test pieces. All test pieces shall satisfy the requirements. If the requirements are still not satisfied in these new tests, the tube shall be rejected.

Two further tubes shall be taken from the batch concerned in place of the rejected sample tube and shall be submitted to the tests specified in subclauses 5.5.1 and 5.5.2. If one of the requirements is still not fulfilled, the entire batch shall be considered not to comply with the standard. However, individual testing may be agreed between the parties concerned.

If the unsatisfactory result of testing can be improved by means of heat treatment or other suitable measures, the supplier shall be given the opportunity to submit a batch which has not been accepted again for acceptance inspection. If the test pieces continue to fail to satisfy the requirements the entire batch shall be considered not to comply with the standard.

5.6.3 Test results which can be traced back to improperly carried out sampling, sample preparation or test procedure or to an accidental and limited defect in a test piece shall be deemed invalid.

5.7 Documents on materials testing

5.7.1 A document DIN 50 049 – 2.2 (test report) shall be issued for tubes which have not undergone acceptance inspection.

5.7.2 Depending on the agreement at the time of ordering (see subclause 5.1), either a document DIN 50 049 – 3.1 B (inspection certificate B) or a document DIN 50 049 – 3.1 C (inspection certificate C) shall be issued for tubes which have undergone acceptance inspection.

If it has been agreed to check chemical composition by means of the product analysis, the result shall be reported in an inspection certificate B.

5.7.3 The marking applied to the tubes as specified in clause 6 shall be stated in the documents.

6 Marking

6.1 All tubes supplied in accordance with this standard shall be clearly and durably marked on the tube end as follows:

- manufacturer's mark;
- symbol identifying the steel grade;
- an appended *S* indicating that the tube is of the seamless type;
- inspector's mark (where acceptance inspection has been agreed).

6.2 Marking shall generally be applied by stamping. A different marking method is also permitted for tubes with small outside diameters and/or small wall thicknesses (e.g. labelling the bundle of tubes).

7 Complaints

7.1 In accordance with current law, a complaint may only be raised against defective tubes if the defects noticeably impair their use. This shall apply unless otherwise agreed at the time of ordering.

7.2 It is normal and practical for the purchaser to give the supplier the opportunity to judge whether the complaints are justified, if possible by submitting the tube objected to or samples of the tubes supplied.

Standards and other documents referred to

| | |
|---|---|
| DIN 1629 | (at present at the stage of draft) Seamless circular unalloyed steel tubes subject to special requirements; technical delivery conditions |
| DIN 1630 | (at present at the stage of draft) High-performance seamless circular unalloyed steel tubes; technical delivery conditions |
| DIN 2448 | Seamless steel tubes; dimensions, masses per unit length |
| DIN 8528 Part 1 | Weldability; metallic materials, concepts |
| DIN 17 100 | Steels for general structural purposes; quality standard |
| DIN 17 124 | (at present at the stage of draft) Seamless circular fine grain steel tubes for structural steelwork; technical delivery conditions |
| DIN 50 049 | Documents on materials testing |
| DIN 50 115 | Testing of metallic materials; impact test |
| DIN 50 125 | Testing of metallic materials; tensile test pieces, guidelines for their preparation |
| DIN 50 140 | Testing of metallic materials; tensile test on tubes and strips from tubes |
| DIN 50 145 | Testing of metallic materials; tensile test |
| DIN EN 39 | Steel tubes for working scaffolds; requirements, tests |
| <i>Stahl-Eisen-Prüfblatt</i> 1805 ²⁾ | <i>Probenahme und Probenvorbereitung für die Stückanalyse bei Stählen</i> (Sampling and sample preparation for the product analysis of steels) |
| <i>Handbuch für das Eisenhüttenlaboratorium</i> 2) (Handbook for the Ferrous Metallurgy Laboratory) | Volume 2: <i>Die Untersuchung der metallischen Stoffe</i> (Investigation of metallic materials); Düsseldorf, 1966; Volume 5 (supplement): A 4.4 – <i>Aufstellung empfohlener Schiedsverfahren</i> (List of recommended arbitration procedures); B – <i>Probenahmeverfahren</i> (Sampling procedures); C – <i>Analysenverfahren</i> (Methods of analysis); most recent edition in each case. |

Other relevant standards

| | |
|------------|---|
| DIN 17 119 | Welded cold formed square and rectangular steel tubes (hollow sections) for structural steelwork; technical delivery conditions |
| DIN 17 120 | Welded circular steel tubes for structural steelwork; technical delivery conditions |

Explanatory notes

The first editions of the DIN Standards for welded cold formed square and rectangular tubes or hollow sections (see DIN 17 119), welded circular tubes (see DIN 17 120) and seamless circular tubes (see DIN 17 121) for structural steelwork have been prepared in a joint committee of the *Normenausschuss Eisen und Stahl (FES)* (Iron and Steel Standards Committee) and the *Normenausschuss Rohre, Rohrverbindungen und Rohrleitungen (FR)* (Pipes, Pipe Joint Assemblies and Pipelines Standards Committee). In consideration of the differing applications and the consequent differences in the requirements (type and scope of test programme), it was deemed expedient to separate the technical delivery conditions for the products mentioned above which are used in structural steelwork from the delivery conditions for tubes used in process plant, vessel and pipeline construction (see DIN 1615, DIN 1626 and DIN 1628 for welded tubes, DIN 1629 and DIN 1630 for seamless tubes, each at present at the stage of draft, August 1982 editions).

The classification into grades, the values relating to the chemical composition and the mechanical properties of the steels covered by DIN 17 119, DIN 17 120 and DIN 17 121 correspond, to a great extent, to the specifications for general structural steels complying with DIN 17 100. Separate delivery conditions are in preparation for fine grain steel tubes or hollow sections for structural steelwork (DIN 17 123, DIN 17 124 and DIN 17 125, at present at the stage of draft).

In the case of circular tubes, the specifications relating to the permissible deviations with regard to dimension, form and mass have been aligned with those for the tubes used in process plant, vessel and pipeline construction.

International Patent Classification

F 16 L 9/02

²⁾ Publisher: *Verein Deutscher Eisenhüttenleute*; supplied by: *Verlag Stahleisen mbH*, Postfach 82 29, D-4000 Düsseldorf 1.