

UDC 621.882.215.3

October 1989

Slotted countersunk head screws
for structural steel bolting
for supply with or without nut

DIN
7969

Senkschrauben mit Schlitz ohne Mutter oder mit Sechskantmutter
für Stahlkonstruktionen

Supersedes December 1970
edition.

In keeping with current practice in standards published by the International Organization for Standardization (ISO), a comma has been used throughout as the decimal marker.

The new widths across flats 16 mm, 18 mm and 34 mm as specified in ISO 272 should be used instead of the previous widths across flats 17 mm, 19 mm and 32 mm for thread sizes M 10, M 12 and M 22.

Dimensions in mm

1 Scope and field of application

This standard specifies requirements for M 10 to M 24 slotted countersunk head screws assigned to product grade C for use in structural steel bolting.

2 Dimensions

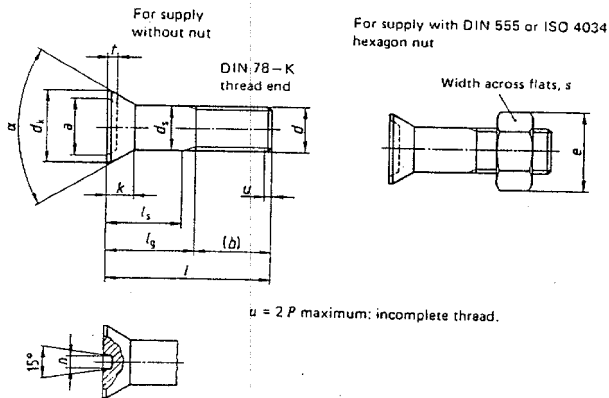

$u = 2P$ maximum: incomplete thread.

Continued on pages 2 to 5

Thread size (d)	M10	M12	M16	M20	M22	M24
$P^{1)}$	1.5	1.75	2	2.5	2.5	3

Page 2 DIN 9699

Table.

Thread size (d)	M10	M12	M16	M20	M22	M24
$P^{1)}$	1.5	1.75	2	2.5	2.5	3
a	75° + 5° 0			60° + 5° 0		
a	14	16	22	25	27	29
b	20	22	28	32	35	38
(auxiliary dimension) $b^2)$	25	28	35	40	45	50
d_k max = nominal size	17	21	28	32	35	38
min	16.57	20.48	27.48	31.38	34.38	37.38
Nominal size	10	12	16	20	22	24
d_c min	9.42	11.3	15.3	19.16	21.16	23.16
max	10.58	12.7	16.7	20.64	22.84	24.84
e min	17.59 18.72	19.65 20.88	26.17	32.95	37.29 35.03	39.55
Nominal size	5.5	7	9	11.5	12	13
k min	5.26	6.71	8.71	11.15	11.65	12.65
max	5.74	7.29	9.29	11.65	12.35	13.35
n min = nominal size	2.5	3	4	5	5	5
max	2.75	3.25	4.3	5.3	5.3	5.3
s max = nominal size	16 ⁴⁾ 17	18 ⁴⁾ 19	24	30	34 ⁴⁾ 32	36
min	15.75 16.57	17.57 18.48	23.16	29.16	33 31	35
t	3	4	4	4	5	6

Nominal size			Lengths (l_s^*) and (l_g^{**})													
			l_s min	l_s max	l_s min	l_s max	l_s min	l_s max	l_s min	l_s max	l_s min	l_s max	l_s min	l_s max	l_s min	l_s max
20	18,95	21,05														
25	23,95	26,05														
30	28,95	31,05														
35	33,75	36,25	7,5	15												
40	38,75	41,25	12,5	20	9,25	18										
45	43,75	46,25	17,5	25	14,25	23	7	17								
50	48,75	51,25	22,5	30	19,25	28	12	22								
55	53,5	56,5	22,5	30	24,25	33	17	27	10,5	23	7,5	20				
60	58,5	61,5	27,5	35	29,25	38	22	32	15,5	28	12,5	25	7	22		
65	63,5	66,5	32,5	40	34,25	43	27	37	20,5	33	17,5	30	12	27		
70	68,5	71,5	37,5	45	39,25	47	32	42	25,5	38	22,5	35	17	32		
75	73,5	76,5	42,5	50	44,25	52	37	47	30,5	43	27,5	40	22	37		
80	78,5	81,5	47,5	55	49,25	57	42	52	35,5	48	32,5	45	27	42		
90	88,25	91,75	57,5	65	59,25	67	45	55	37,5	50	32,5	45	25	40		
100	98,25	101,75	67,5	75	69,25	77	55	65	47,5	60	42,5	55	35	50		
110	108,25	111,75	77,5	85	79,25	87	65	75	57,5	70	52,5	65	45	60		
120	118,25	121,75	87,5	95	89,25	97	75	85	67,5	80	62,5	75	55	70		
130	129	132	97,5	105	99,25	107	85	95	77,5	90	72,5	85	65	80		
140	138	142	107,5	115	109,25	117	95	105	87,5	100	82,5	95	75	90		
150	148	152	117,5	125	119,25	127	105	115	97,5	110	92,5	105	85	100		
160	156	164	127,5	135	129,25	137	115	125	107,5	120	102,5	115	95	110		

¹⁾ $l_{s \text{ min}} = l_{s \text{ max}} - 5 P$

²⁾ $l_{g \text{ max}} = l_{\text{nominal size}} - b$

1) P = pitch of thread.

2) For lengths above the continuous stepped line.

3) For lengths below the continuous stepped line.

4) Where bolts with nuts are ordered, the nuts to be supplied shall comply with ISO 4034 (see foreword on page 1).

Lengths above the dashed line refer to screws threaded up to the head.

3 Technical delivery conditions

Material		Steel
General requirements		As specified in DIN 267 Part 1.
Thread	Tolerance	8g
	As specified in	DIN 13 Parts 12 and 15.
Mechanical properties	Property class	4.6
	As specified in	ISO 898 Part 1.
Limit deviations and geometrical tolerances	Product grade	C
	As specified in	ISO 4759 Part 1.
Surface finish		As processed. DIN 267 Part 9 shall apply with regard to electroplating. DIN 267 Part 10 shall apply with regard to hot dip galvanizing.
Acceptance inspection		DIN 267 Part 5 shall apply with regard to acceptance inspection.

4 Designation

Designation of an M20 slotted countersunk head screw of nominal length, $l = 70$ mm, for supply without nut, of property class 4.6:

Countersunk head screw DIN 7969 – M20 x 70 – 4.6

Designation of an M20 slotted countersunk head screw of nominal length, $l = 70$ mm, for supply with hexagon nut (Mu)¹⁾, of property class 4.6:

Countersunk head screw DIN 7969 – M20 x 70 – Mu – 4.6

The designation signifies that the widths across flats for sizes M10, M12 and M22 are those hitherto specified, i.e. 17 mm, 19 mm and 32 mm. If screws are to be supplied with a new width across flats as specified in ISO 272 (16 mm, 18 mm or 34 mm), the width across flats (SW) shall be included in the designation, e.g.

Countersunk head screw DIN 7969 – M12 x 70 – Mu – SW 18 – 4.6

The DIN 4000 – 2 – 1 tabular layout of article characteristics shall apply for screws covered in this standard.

¹⁾ Where the screws are supplied in given quantities, the nuts may accompany the consignment in bulk packaging.

Page 4 DIN 7969

5 Mass

The values given should be regarded as guideline values.

Thread size (d)	M10	M12	M16	M20	M22	M24
Length, l	Mass with nut (7,85 kg/dm ³), in kg per 1000 units ≈					
20	23,7					
25	26,2	39,5				
30	28,7	43,1	83,5			
35	32,3	46,8	90,2			
40	35,4	52,2	96,8			
45	38,5	56,6	105			
50	41,6	61,1	113	185		
55	44,1	65,5	121	200	249	
60	47,1	70	129	212	264	320
65	50,2	73,4	137	225	279	338
70	53,3	77,8	145	237	294	356
75	56,4	82,3	153	249	309	373
80	58,5	86,7	161	262	324	391
90	65,6	95,6	175	283	350	420
100	71,8	104	190	308	379	455
110	77,9	113	206	333	409	490
120	84,1	122	222	357	439	527
130	90,3	131	238	381	469	562
140	96,4	140	253	406	499	598
150	103	149	269	431	528	633
160	109	158	285	456	558	669
Mass of nuts, in kg per 1000 units, ≈	10,9	15,9	30,8	60,3	80,2	103

As a rule, screws are manufactured in the sizes for which the mass has been given.

Standards referred to

DIN	13 Part 12	ISO metric screw threads; coarse and fine pitch threads from 1 to 300 mm diameter; selection of diameters and pitches
DIN	13 Part 15	ISO metric screw threads; fundamental deviations and tolerances for screw threads of 1 mm diameter and larger
DIN	78	Thread ends and lengths of projection of bolt ends for ISO metric threads as specified in DIN 13
DIN	267 Part 1	Fasteners; technical delivery conditions; general requirements
DIN	267 Part 5	Fasteners; technical delivery conditions; acceptance inspection (modified version of ISO 3269, 1984 edition)
DIN	267 Part 9	Fasteners; technical delivery conditions; electroplated components
DIN	267 Part 10	Fasteners; technical delivery conditions; hot dip galvanized components
DIN	555	M5 to M100 X 6 hexagon nuts; product grade C
DIN	4000 Part 2	Tabular layout of article characteristics for bolts, screws and nuts
ISO	272	Fasteners; hexagon products; widths across flats
ISO	898 Part 1	Mechanical properties of fasteners; bolts, screws and studs
ISO	4034	Hexagon nuts; product grade C
ISO	4759 Part 1	Tolerances for fasteners; bolts, screws and nuts with thread diameters $\geq 1,6$ and ≤ 150 mm and product grades A, B and C

Previous editions

DIN 7969: 07.55, 03.63, 12.70.

Amendments

The following amendments have been made to the December 1970 edition.

- a) Widths across flats 16 mm, 18 mm and 34 mm as specified in ISO 272 have been adopted additionally for thread sizes M 10, M 12 and M 22.
- b) The scope of the standard has been extended to include screws for supply with hexagon nuts as specified in ISO 4034.
- c) Nut height m is no longer specified.
- d) Limits of size are now specified.
- e) Lengths l_s and l_e are now specified.
- f) Property classes 5.6 and 8.8 are no longer specified.
- g) Screws are now to be hot dip galvanized as specified in DIN 267 Part 10.
- h) The standard has been editorially revised.

International Patent Classification

E 04 B 1/38
 F 16 B 33/00
 F 16 B 37/00
 F 16 B 5/02
 F 16 B 23/00