

September 1995

Cross recessed head thread cutting screws

Dimensions, requirements and testing

DIN 7516

ICS 21 060 10

Supersedes November 1986 edition.

Descriptors: Thread cutting screws, fasteners, screws.

Gewinde-Schnellschrauben; Kreuzschlitzschrauben; MäÙe, Anforderungen, Prüfung

In keeping with current practice in standards published by the International Organization for Standardization (ISO), a comma has been used throughout as the decimal marker.

Foreword

This standard has been prepared by the *NormenausschuÙ Mechanische Verbindungselemente* (Fasteners Standards Committee)

Amendments

The following amendments have been made to the November 1986 edition.

- a) The references to other DIN Standards have been updated.
- b) An 'E' has been added to each screw head type.
- c) The maximum core hardness has been reduced (to 370 HV).
- d) The standard has been editorially revised.

Previous editions

DIN 7516: 1959-08, 1971-08, 1986-11.

1 Scope and field of application

This standard specifies dimensions, requirements and test methods for heat-treated cross recessed head thread cutting screws with an ISO metric thread as specified in DIN 13-12, with cutting flutes extending from the point of the screw to its head, and designed to cut their mating thread during assembly. See the relevant DIN Standards for head styles, ISO 8992 for general requirements, and ISO 3269 for acceptance inspection.

The specifications of this standard are intended to ensure that thread cutting screws are capable of performing the above functions without fracturing or their own thread being deformed. To that end, requirements have been specified for thread cutting capability, surface hardness, tensile strength and torsional strength.

2 Normative references

This standard incorporates, by dated or undated reference, provisions from other publications. These normative references are cited at the appropriate places in the text and the publications are listed hereafter. For dated references, subsequent amendments to or revisions of any of these publications apply to this standard only when incorporated

in it by amendment or revision. For undated references, the latest edition of the publication referred to applies.

DIN 13-12

ISO metric screw threads; coarse and fine pitch threads with diameters from 1 to 300 mm; selected diameters and pitches

DIN 13-15

ISO metric screw threads; fundamental deviations and tolerances for screw threads of 1 mm diameter and larger

DIN 1654-3

Cold heading and cold extruding steels; technical delivery conditions for case hardening steels

DIN 1654-4

Cold heading and cold extruding steels; technical delivery conditions for steels for quenching and tempering

DIN 4000-2

Tabular layouts of article characteristics for bolts, screws and nuts

DIN 17 210

Case hardening steel; technical delivery conditions

DIN 50 133

Vickers hardness testing of metallic materials; HV 0.2 to HV 100

Continued on pages 2 to 5.

Page 2 DIN 7516

DIN 50 190-1

Determination of effective case depth of heat-treated parts after carburizing

DIN EN 10 083-2

Quenched and tempered steels; technical delivery conditions for unalloyed quality steels

DIN EN ISO 4757

Cross recesses for screws (ISO 4757: 1983)

DIN EN ISO 7045

Cross recessed pan head screws; product grade A (ISO 7045: 1994)

DIN EN ISO 7046-1

Countersunk flat head screws (common head style) with type H or type Z cross recess; product grade A (ISO 7046-1: 1994)

DIN EN ISO 7047

Countersunk raised head screws (common head style) with type H or type Z cross recess; product grade A (ISO 7047: 1994)

ISO 3269: 1988

Fasteners; acceptance inspection

ISO 4042: 1989

Threaded components; electroplated coatings

ISO 4758-1: 1978



Tolerances for fasteners; bolts, screws and nuts with thread diameters between 1,6 (inclusive) and 150 mm (inclusive) and product grades A, B and C

ISO 8992: 1986

Fasteners; general requirements for bolts, screws, studs and nuts

3 Dimensions and designation

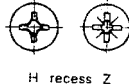
Table 1: Screw types and designations

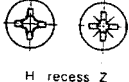
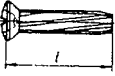
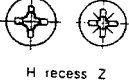
Type	Illustration	Type of cross recess as in DIN EN ISO 4757	Other dimensions as in	Example of designation ¹⁾
AE		 H recess Z	DIN EN ISO 7045	Screw DIN 7516 - AE M5 x 20 - St - H
DE		 H recess Z	DIN EN ISO 7046-1	Screw DIN 7516 - DE M5 x 20 - St - H
EE		 H recess Z	DIN EN ISO 7047	Screw DIN 7516 - EE M5 x 20 - St - H

¹⁾ If the designation does not include the symbol H or Z identifying the cross recess, recess type H shall apply.

The DIN 4000 - 2 - 1 tabular layout of article characteristics shall apply to screws as covered in this standard

Thread end

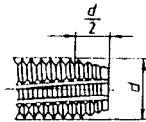

Thread core hole

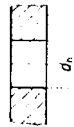

The edge of the core hole on the insertion side shall be sharp-edged

Table 2: Range of commercial sizes and core hole diameters

Dimensions in mm

Thread size	M3	M4	M5	M6	M8
Nominal length, $l^1)$	Range of commercial sizes ²⁾				
6) ³⁾) ³⁾)))
8					
10					
12))
(14)					
16					
(18)					
20					
(22)					
25					
30					
35					
40					
	Core hole diameter ⁴⁾				
d_h (H11)	2,7	3,6	4,5	5,5	7,4

¹⁾ Bracketed sizes should be avoided if possible.

²⁾ The zone between the stepped lines indicates the range of commercial sizes. These sizes only are covered by this standard.

³⁾ Not for types DE and EE.

⁴⁾ Designed for workpieces made from materials of medium strength. For thin-walled workpieces or workpieces made from soft materials, a smaller core hole diameter, for thick-walled workpieces or workpieces made from hard materials, a larger core hole diameter may be chosen. It is recommended that the selection be made on the basis of tests. The depth of engagement should not exceed $2 d$.

Page 4 DIN 7516

4 Requirements

4.1 General requirements

ISO 8992 shall apply with regard to the general requirements.

4.2 Design

ISO 4759-1, product grade A, shall apply with regard to the design, unless other specifications have been made in the relevant dimensional standards.

4.3 Material

Thread cutting screws may be made of case hardening steel as specified in DIN 17 210 or quenched and tempered steel as specified in DIN EN 10 083-2 or of steels as specified in DIN 1653-3 and DIN 1654-4. Use of other materials being subject to agreement.

4.4 Thread

The thread of thread cutting screws shall be such that the thread formed is capable of accommodating a screw with ISO metric screw thread complying with DIN 13-15 and produced to tolerance 6h. The form of thread and thread tolerance for the screws shall be at the manufacturer's discretion.

4.5 Surface finish

ISO 4042 shall apply with regard to electroplating, other types of surface finish being the subject of agreement.

4.6 Metallurgical properties

4.6.1 Surface hardness

The surface hardness of thread cutting screws shall, after heat treatment, be at least 450 HV 0.3.

4.6.2 Case depth

The case depth of screws shall comply with the values specified in table 3.

Table 3: Case depth

Thread size	Dimensions in mm	
	Case depth (Eht 450)	
	Minimum	Maximum
M3	0,05	0,18
M4 and M5	0,10	0,25
M6 and M8	0,15	0,28

4.6.3 Core hardness

The core hardness of screws shall, after heat treatment, be between 240 HV 5 and 370 HV 5

4.6.4 Microstructure

The microstructure of screws shall, after heat treatment, show no band of free ferrite between core and case

4.7 Mechanical properties

4.7.1 Thread cutting capability

Thread cutting screws shall be capable of cutting a mating thread when driven into a test plate as specified in subclause 5.2, without their own thread being deformed

4.7.2 Torsional strength

The torsional strength of thread cutting screws shall be such that, when tested in accordance with subclause 5.2.2, the torque necessary to cause failure (breaking torque) is equal to or greater than the minimum values specified in table 5.

4.7.3 Tensile strength

The tensile strength of thread cutting screws shall be such that, when tested in accordance with subclause 5.2.3, the torque necessary to cause failure (breaking torque) is equal to or greater than the minimum values specified in table 6.

5 Testing

5.1 Metallurgical properties

5.1.1 Determination of surface hardness

The surface hardness shall be determined in accordance with DIN 50 133, the impression being made on the flat section of the screw, preferably on the screw head.

5.1.2 Determination of case depth

The case depth may be determined by examining a micro-section made at the thread flank mid-point (i.e. between crest and root) with a microscope.

Determination of the case depth using hardness tests is covered by DIN 50 190-1.

5.1.3 Determination of core hardness

The core hardness shall be determined in accordance with DIN 50 133.

5.1.4 Examination of microstructure

The microstructure of the screw shall be examined metallographically.

5.2 Mechanical properties

5.2.1 Drive test

The drive test shall be carried out using the test assembly shown in figure 1 by way of example.

The screw to be tested shall be driven into a test plate until one full-form thread projects above the surface of the plate. The test plate material shall have a carbon content not exceeding 0.23 %, its hardness being between 110 HB and 130 HB. The thickness of the test plate shall be as specified in table 4.

Table 4: Test plate details and cutting torques

Thread size	Plate thickness, in mm	Hole diameter, in mm (H9)	Maximum cutting torque, in Nm
M3	3	2,7	0,9
M4	4	3,6	2,1
M5	5	4,5	4,2
M6	6	5,5	7,2
M8	8	7,4	17

The core hole in the test plate may be produced by drilling, punching and redrilling, or by reaming or piercing

The force used to drive the screw into the test plate shall not exceed 50 N for sizes up to M5, and 100 N for size M6 or more. The driving speed shall not exceed 30 revolutions per minute, the cutting torque shall not exceed the values given in table 4

Where necessary, the lubricant to be used during the drive test shall be agreed upon.

NOTE: If thread cutting screws are plated by the purchaser, any complaints made to the screw manufacturer need be accepted only if driving tests carried out on screws of the same lot not subsequently plated do not provide satisfactory results.

5.2.2 Torsional strength test

The shank of the screw shall be clamped in a split threaded die with mating thread or in an equivalent device so that the clamped portion of the screw is not damaged. At least two full-form threads shall project above the clamping device, and at least two full-form threads (without screw end) shall be held in the clamping device. In the case of short screws, the complete thread shall be held in the die, the screw head not resting on the device.

The screw shall be tightened until fracture occurs, and the minimum breaking torques shall be established.

5.2.3 Tensile test

The screw (to be tested as a finished component) shall be clamped in a tensile testing machine and subjected to tensile stress until fracture occurs, and the minimum breaking torques shall be established.

Table 5: Minimum breaking torques

Thread size	Minimum breaking torque, in Nm
M3	1,5
M4	3,4
M5	7,1
M6	12
M8	28

Table 6: Minimum breaking forces

Thread size	Minimum breaking force, in N
M3	4 000
M4	7 000
M5	11 400
M6	16 000
M8	29 000

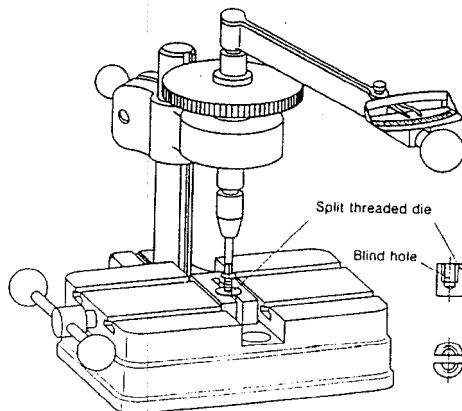

Figure 1