

September 1995

Hexagon head and slotted head thread
cutting screws

Dimensions, requirements and testing

DIN
7513

ICS 21.060.10

Supersedes November 1986 edition.

Descriptors: Screws, thread cutting screws, fasteners.

Gewinde-Schneidschrauben; Sechskantschrauben, Schlitzschrauben; Maße, Anforderungen, Prüfung

*In keeping with current practice in standards published by the International Organization for Standardization (ISO), a comma has been used throughout as the decimal marker.***Foreword**

This standard has been prepared by the Normenausschuß Mechanische Verbindungselemente (Fasteners Standards Committee).

Amendments

The following amendments have been made to the November 1986 edition.

- The references to other DIN Standards have been updated.
- An 'E' has been added to each screw head type (except for type A).
- The maximum core hardness has been reduced (to 370 HV).
- The standard has been editorially revised.

Previous editions

DIN 7513: 1943x-08, 1956-05, 1968-03, 1971-08, 1986-11.

1 Scope and field of application

This standard specifies dimensions, requirements and test methods for heat-treated hexagon head and slotted head thread cutting screws with an ISO metric thread as specified in DIN 13-12, with cutting flutes extending from the point of the screw to its head, and designed to cut their mating thread during assembly. See the relevant DIN Standards for head styles, ISO 8992 for general requirements, and ISO 3269 for acceptance inspection.

The specifications of this standard are intended to ensure that thread cutting screws are capable of performing the above functions without their own thread fracturing or becoming deformed. To that end, requirements have been specified for thread cutting capability, surface hardness, tensile strength and torsional strength.

2 Normative references

This standard incorporates, by dated or undated reference, provisions from other publications. These normative references are cited at the appropriate places in the text and the publications are listed hereafter. For dated refer-

ences, subsequent amendments to or revisions of any of these publications apply to this standard only when incorporated in it by amendment or revision. For undated references, the latest edition of the publication referred to applies.

DIN 13-12

ISO metric screw threads; coarse and fine pitch threads with diameters from 1 to 300 mm; selected diameters and pitches

DIN 13-15

ISO metric screw threads; fundamental deviations and tolerances for screw threads of 1 mm diameter and larger

DIN 1654-3

Cold heading and cold extruding steels; technical delivery conditions for case hardening steels

DIN 1654-4

Cold heading and cold extruding steels; technical delivery conditions for steels for quenching and tempering

DIN 4000-2

Tabular layouts of article characteristics for bolts, screws and nuts

Continued on pages 2 to 5

Page 2 DIN 7513

DIN 17 210

Case hardening steel, technical delivery conditions

DIN 50 133

Vickers hardness testing of metallic materials, HV 0,2 to HV 100

DIN 50 190-1

Determination of effective case depth of heat treated parts after carburizing

DIN EN 10 083-2

Quenched and tempered steels, technical delivery conditions for unalloyed quality steels

DIN EN 24 017

Hexagon head screws, product grades A and B (ISO 4017 1988)

DIN EN ISO 1207

Slotted cheese head screws; product grade A (ISO 1207 1992)

DIN EN ISO 2009

Slotted countersunk head screws (common head style), product grade A (ISO 2009 1994)

DIN EN ISO 2010

Slotted raised countersunk head screws (common head style), product grade A (ISO 2010 1994)

ISO 3269 1988

Fasteners; acceptance inspection

ISO 4042 1989

Threaded components; electroplated coatings

ISO 4759-1 1978



Tolerances for fasteners; bolts, screws and nuts with thread diameters between 1,6 (inclusive) and 150 mm (inclusive) and product grades A, B and C

ISO 8992 1986

Fasteners; general requirements for bolts, screws, studs and nuts

3 Dimensions and designations

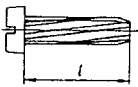
Table 1: Screw types and designations

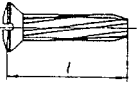
Type	Illustration	Other dimensions as in	Example of designation
A		DIN EN 24017	Screw DIN 7513 – A M5 × 20 – St
BE		DIN EN ISO 1207	Screw DIN 7513 – BE M5 × 20 – St
FE		DIN EN ISO 2009	Screw DIN 7513 – FE M5 × 20 – St
GE		DIN EN ISO 2010	Screw DIN 7513 – GE M5 × 20 – St

The DIN 4000 – 2 – 1 tabular layout of article characteristics shall apply to screws as covered in this standard.



The edge of the core hole on the insertion side shall be sharp-edged.

Table 2: Range of commercial sizes and core hole diameters

Dimensions in mm

Type	BE, FE and GE		A, BE, FE and GE			
Thread size	M2,5	M3	M4	M5	M6	M8
Nominal length, $l^1)$	Range of commercial sizes ²⁾					
6	3)	3)				
8						
10			3)			
12					3)	
(14)						
16						
(18)						
20						
(22)						
25						
30						
35						
40						
	Core hole diameter ⁴⁾					
d_h (mm)	2,2	2,7	3,6	4,5	5,5	7,4

1) Bracketed sizes should be avoided if possible.

2) The zone between the continuous thick lines indicates the commercial sizes. These screws only are covered by this standard.

3) Not for types FE and GE.

4) Designed for workpieces made from materials of medium strength. For thin-walled workpieces or workpieces made from soft materials, a smaller core hole diameter, for thick-walled workpieces or workpieces made from hard materials, a larger core hole diameter may be chosen. It is recommended that the selection be made on the basis of tests. The depth of engagement should not exceed $2d$.

4 Requirements

4.1 General requirements

Thread cutting screws shall meet the general requirements specified in ISO 8992.

4.2 Design

The design and dimensional accuracy of thread cutting screws shall comply with ISO 4759-1, product grade A, unless otherwise specified in the relevant dimensional standards.

4.3 Material

Thread cutting screws may be made of case hardening steel as specified in DIN 17 210 or quenched and tempered steel as specified in DIN EN 10 083-2, or of steels as specified in DIN 1654-3 and DIN 1654-4, use of other materials being subject to agreement.

4.4 Thread

The thread of thread cutting screws shall be such that the thread formed is capable of accommodating a screw with ISO metric screw thread complying with DIN 13-15 and produced to tolerance 6h. The form of thread and thread tolerance for the screws shall be at the manufacturer's discretion.

4.5 Surface finish

ISO 4042 shall apply with regard to electroplating, other types of surface finish being the subject of agreement.

4.6 Metallurgical properties

4.6.1 Surface hardness

The surface hardness of thread cutting screws shall, after heat treatment, be at least 450 HV 0,3.

4.6.2 Case depth

The case depth of screws shall comply with the values specified in table 3.

Table 3: Case depth

Thread size	Case depth (Eht 450)	
	Minimum	Maximum
M2,5	0,04	0,12
M3	0,05	0,18
M4 and M5	0,10	0,25
M6 and M8	0,15	0,28

Dimensions in mm

4.6.3 Core hardness

The core hardness of screws shall, after heat treatment, be between 240 HV 5 and 370 HV 5.

4.6.4 Microstructure

The microstructure of screws shall, after heat treatment, show no band of free ferrite between core and case.

4.7 Mechanical properties

4.7.1 Thread cutting capability

Thread cutting screws shall be capable of cutting a mating thread when driven into a test plate as specified in subclause 5.2.1, without their own thread becoming deformed.

4.7.2 Torsional strength

The torsional strength of thread cutting screws shall be such that, when tested in accordance with subclause 5.2.2, the torque necessary to cause failure (breaking torque) is equal to or greater than the minimum values specified in table 5.

4.7.3 Tensile strength

The tensile strength of thread cutting screws shall be such that, when tested in accordance with subclause 5.2.3, the torque necessary to cause failure (breaking torque) is equal to or greater than the minimum values specified in table 6.

5 Testing

5.1 Metallurgical properties

5.1.1 Determination of surface hardness

The surface hardness shall be determined in accordance with DIN 50 133, the impression being made on a flat section of the screw, preferably on the screw head.

5.1.2 Determination of case depth

The case depth may be determined by examining a micro-section made at the thread flank mid-point (i.e. between crest and root) with a microscope.

Determination of the case depth using hardness tests is covered by DIN 50 190-1.

5.1.3 Determination of core hardness

The core hardness shall be determined in accordance with DIN 50 133.

5.1.4 Examination of microstructure

The microstructure of the screw material shall be examined metallographically.

5.2 Mechanical properties

5.2.1 Drive test

The drive test shall be carried out using the test assembly shown in figure 1 by way of example.

The screw to be tested shall be driven into a test plate until one full-form thread projects above the surface of the plate.

The test plate material shall have a carbon content not exceeding 0,23 %, its hardness being between 110 HB and 130 HB. The thickness of the test plate shall be as specified in table 4.

Table 4: Test plate details and cutting torques

Thread size	Plate thickness, in mm	Hole diameter, in mm (H9)	Maximum cutting torque, in Nm
M2,5	2,5	2,2	0,6
M3	3	2,7	0,9
M4	4	3,6	2,1
M5	5	4,5	4,2
M6	6	5,5	7,2
M8	8	7,4	17

The core hole in the test plate may be produced by drilling, punching and redrilling, or by reaming or piercing.

The force used to drive the screw into the test plate shall not exceed 50 N for sizes up to M5, and 100 N for size M6 or more. The driving speed shall not exceed 30 revolutions per minute, the cutting torque shall not exceed the values given in table 4.

Where necessary, the lubricant to be used during the drive test shall be agreed upon.

NOTE: If thread cutting screws are plated by the purchaser, any complaints made to the screw manufacturer need be accepted only if driving tests carried out on screws of the same lot not subsequently plated do not provide satisfactory results.

5.2.2 Torsional strength test

The shank of the screw shall be clamped in a split threaded die with mating thread or in an equivalent device so that the clamped portion of the screw is not damaged. At least two full-form threads shall project above the clamping device, and at least two full-form threads (without screw end) shall be held in the clamping device. In the case of short screws, the complete thread shall be held in the die, the screw head not resting on the device.

The screw shall be tightened until fracture occurs, and the minimum breaking torques shall be established.

Table 5: Minimum breaking torques

Thread size	Minimum breaking torque, in Nm
M2,5	1
M3	1,5
M4	3,4
M5	7,1
M6	12
M8	28

5.2.3 Tensile test

The screw (to be tested as a finished component) shall be clamped in a tensile testing machine and subjected to tensile stress until fracture occurs, and the minimum breaking torques shall be established.

Table 6: Minimum breaking forces

Thread size	Minimum breaking force, in N
M2,5	2 700
M3	4 000
M4	7 000
M5	11 400
M6	16 000
M8	29 000

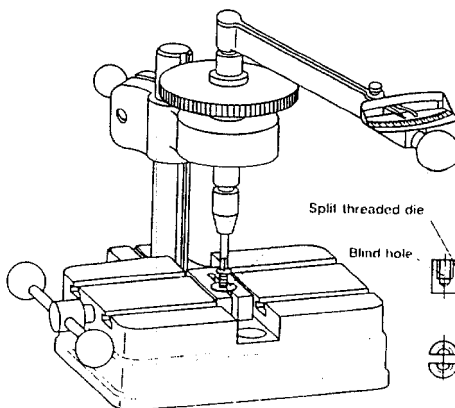

Figure 1