

UDC 621.882.215.3.091.5

August 1990

Cross recessed raised countersunk head screws

DIN
966

Linsen-Senkschrauben mit Kreuzschlitz

Supersedes December 1984 edition.

In keeping with current practice in standards published by the International Organization for Standardization (ISO), a comma has been used throughout as the decimal marker.

This standard should be used together with ISO 7047. For details, see Explanatory notes. It is intended to withdraw the present standard by 31 July 1995 at the latest.

Dimensions in mm

1 Scope and field of application

This standard specifies requirements for M1,6 to M10 cross recessed raised countersunk head screws assigned to product grade A. See DIN 962 (or the standards referred to therein) for special screw types or finishes.

If, in special cases, screws are to comply with specifications other than those given in this standard (e.g. regarding property class or material), these shall be selected in accordance with the relevant standards.

2 Dimensions

Raised countersunk head screw threaded up to the head
 (specified in table 1 above dashed line)

Raised countersunk head screw with unthreaded portion of shank
 (specified in table 1 below dashed line)¹⁾

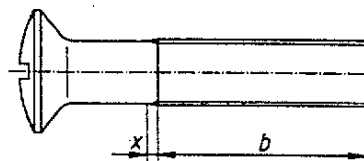
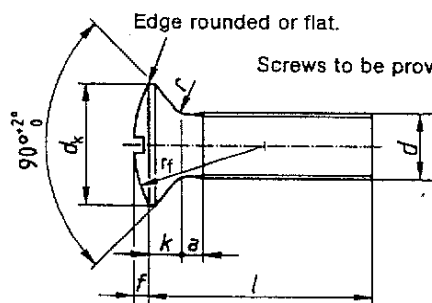

Other dimensions and details as at left.

The shank diameter may be equal to the thread diameter (normal shank) or approximately equal to the pitch diameter (reduced shank), at the manufacturer's discretion.

Cross recess type H

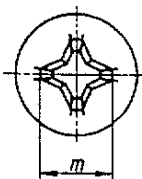

Cross recess type Z

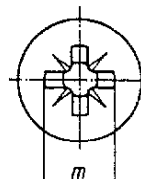

¹⁾ If countersunk head screws with lengths given below the dashed line are to be supplied with their shank threaded up to the head, letter A shall be included in the designation, in accordance with DIN 962.

Continued on pages 2 to 5

Table 1.

Thread size (d ¹⁾)			M1,6	M2	M2,5	M3	(M3,5)	M4	M5	M6	M8	M10	
p ²⁾			0,35	0,4	0,45	0,5	0,6	0,7	0,8	1	1,25	1,5	
a	max.		0,7	0,8	0,9	1	1,2	1,4	1,6	2	2,5	3	
b	min.		15	16	18	19	20	22	25	28	34	40	
d _k	max. = nominal size		3	3,8	4,7	5,8	6,5	7,5	9,2	11	14,5	18	
	min.		2,75	3,5	4,4	5,3	6,14	7,14	8,84	10,57	14,07	17,57	
f	≈		0,4	0,5	0,6	0,75	0,9	1	1,25	1,5	2	2,5	
k	max.		0,96	1,2	1,5	1,65	1,93	2,2	2,5	3	4	5	
r	max.		0,4	0,5	0,7	0,8	0,95	1	1,3	1,6	2	2,5	
r _f	≈		3	4	5	6	7	8	10	12	16	20	
x	max.		0,9	1	1,1	1,25	1,5	1,75	2	2,5	3,2	3,8	
Cross recess No.			0	1			2			3	4		
m ≈			1,9	2,5	2,7	3,1	4,2	4,5	5,3	6,8	9	10	
Cross recess	type H Penetration depth		min.	0,74	1,1	1,3	1,7	1,74	2,04	2,77	3,03	4,18	5,38
	max.			1,1	1,4	1,6	2	2,24	2,54	3,27	3,53	4,68	5,88
m ≈			1,8	2,4	2,8	3,1	4,3	4,6	5,3	7	8,8	9,9	
Cross recess	type Z Penetration depth		min.	0,89	1,04	1,5	1,83	1,93	2,26	2,89	3,3	4,06	5,28
	max.			1,14	1,35	1,75	2,08	2,39	2,72	3,35	3,76	4,52	5,74
Nominal size l ^{1), 3)}			Approximate mass (7,85 kg/dm ³), per 1000 units, in kg										
	min.	max.											
3	2,8	3,2	0,067	0,119	0,211								
4	3,75	4,25	0,078	0,138	0,242	0,350	0,536						
5	4,75	5,25	0,090	0,156	0,272	0,395	0,596	0,824					
6	5,75	6,25	0,102	0,175	0,302	0,439	0,656	0,902	1,49				
8	7,7	8,3	0,125	0,212	0,362	0,527	0,775	1,06	1,73	2,66			
10	9,7	10,3	0,145	0,249	0,422	0,615	0,894	1,21	1,98	3,01	6,14		
12	11,65	12,35	0,165	0,287	0,482	0,703	1,01	1,37	2,23	3,36	6,78	11,7	
(14)	13,65	14,35	0,184	0,325	0,543	0,791	1,13	1,52	2,47	3,72	7,41	12,7	
16	15,65	16,35	0,204	0,362	0,603	0,879	1,25	1,68	2,72	4,07	8,05	13,7	
(18)	17,65	18,35		0,397	0,663	0,968	1,37	1,83	2,97	4,42	8,68	14,7	
20	19,6	20,4		0,439	0,723	1,06	1,49	1,99	3,22	4,78	9,32	15,7	
(22)	21,6	22,4			0,783	1,14	1,61	2,14	3,46	5,13	9,95	16,7	
25	24,6	25,4			0,874	1,28	1,79	2,37	3,83	5,66	10,9	18,2	
(28)	27,6	28,4				1,41	1,97	2,61	4,11	6,19	11,8	19,7	
30	29,6	30,4				1,50	2,09	2,76	4,44	6,55	12,5	20,7	
35	34,5	35,5					2,39	3,15	4,93	7,43	14,1	23,7	
40	39,5	40,5						3,53	5,68	8,31	15,7	25,7	
45	44,5	45,5							6,43	9,20	17,3	28,2	
50	49,5	50,5							7,18	10,1	18,9	30,7	
55	54	56									20,5	33,2	
60	59	61										35,8	

1) Use of sizes given in brackets should be avoided where possible.
 2) P = pitch of coarse thread.
 3) Screws with lengths above the dashed line are threaded up to the head (b = l - (a + k)).
 Lengths over 60 mm shall be graded in 10 mm steps.
 For commercial lengths (given between stepped lines), values of mass have been specified.

3 Technical delivery conditions

Table 2.

Material		Steel	Stainless steel	Non-ferrous metal
General requirements		As specified in DIN 267 Part 1.		
Screw thread	Tolerance	6g ¹⁾		
	As specified in	DIN 13 Parts 13 and 15.		
Mechanical properties ³⁾	Property class (material)	4.8, 5.8 or 8.8	A2-70 or A4-70	CuZn = Copper-zinc alloy ²⁾
	As specified in	ISO 898 Part 1.	DIN 267 Part 11.	DIN 267 Part 18.
Limit deviations and geometrical tolerances	Product grade	A		
	As specified in	ISO 4759 Part 1.		
Surface finish	As processed. Property class 8.8; (thermally or chemically) blackened.	Bright.	Bright.	
		DIN 267 Part 2 shall apply with regard to surface roughness. DIN 267 Part 19 shall apply with regard to permissible surface discontinuities. DIN 267 Part 9 shall apply with regard to electroplating, other types of surface protection being subject to agreement.		
Cross recess	As specified in DIN 7962.			
Acceptance inspection	DIN 267 Part 5 shall apply with regard to acceptance inspection.			
¹⁾ Only for screws without surface protection, the 6g tolerance makes it possible for normal coating thicknesses to be applied in accordance with DIN 267 Part 9, the reference line not being exceeded. Depending on the coating thickness required, a larger fundamental deviation shall be selected than that for the g position. This might, however, impair the resistance to stripping of the bolt/nut assembly. ²⁾ CuZn = CU2 or CU3, at the manufacturer's discretion. ³⁾ Other property classes or materials, or a particular grade of material (e. g. CU3) shall be subject to agreement.				

4 Designation

Designation of an M6 raised countersunk head screw, of length l (nominal size) = 20 mm, with a type H²⁾ cross recess, assigned to property class 4.8:

Raised countersunk head screw DIN 966 – M6 x 20 – 4.8 – H

DIN 962 shall apply for the designation of types and finishes, with additional information to be given on ordering.

DIN 7500 Part 1 shall apply for thread rolling screws and DIN 7516, for thread cutting screws.

The DIN 4000-2-1 tabular layout of article characteristics shall apply for screws as covered in this standard.

²⁾ Should symbols H and Z not be used in existing documentation based on previous editions of this standard, it shall be assumed that type H is meant. In the future, the cross recess type shall be identified for new designs and in purchase order documents with the symbol H or Z.

Standards referred to

DIN 13 Part 13	ISO metric screw threads; series of preferred sizes for screws, bolts and nuts from 1 mm to 52 mm diameter and limits of size
DIN 13 Part 15	ISO metric screw threads; fundamental deviations and tolerances for screw threads of 1 mm diameter and larger
DIN 78	Thread ends and lengths of projection of bolt ends for ISO metric screw threads in accordance with DIN 13
DIN 267 Part 1	Fasteners; technical delivery conditions; general requirements
DIN 267 Part 2	Fasteners; technical delivery conditions; design and dimensional accuracy
DIN 267 Part 5	Fasteners; technical delivery conditions; acceptance inspection (modified version of ISO 3269, 1984 edition)
DIN 267 Part 9	Fasteners; technical delivery conditions; electroplated parts
DIN 267 Part 11	Fasteners; technical delivery conditions, with addenda to ISO 3506; stainless and acid resistant steel components
DIN 267 Part 18	Fasteners; technical delivery conditions; non-ferrous metal components
DIN 267 Part 19	Fasteners; technical delivery conditions; surface discontinuities on bolts
DIN 962	Bolts, screws, studs and nuts; designations, types and finishes
DIN 4000 Part 2	Tabular layouts of article characteristics for screws and nuts
DIN 7500 Part 1	Thread rolling screws for ISO metric threads; dimensions, requirements and testing
DIN 7516	Cross recessed head thread cutting screws; dimensions, requirements and testing
DIN 7962	Cross recesses for screws (modified version of ISO 4757)
ISO 898 Part 1	Mechanical properties of fasteners; bolts, screws and studs
ISO 4759 Part 1	Tolerances for fasteners; bolts, screws and nuts with thread diameters from 1,6 to 150 mm; product grades A, B and C

Previous editions

DIN 966: 12.71, 12.84.

Amendments

The following amendments have been made to the December 1984 edition.

- A note on the period of validity has been included.
- Commercial lengths have been included for thread sizes M 1,6 and M 2.
- The standard has been editorially revised.

Explanatory notes

In 1983, ISO 7721 was published in order to establish a common head style for all types of countersunk head screws. In the same year, a number of ISO Standards on metric countersunk head screws and countersunk head tapping screws with head styles complying with the specifications given in ISO 7721 were published. In these standards, a countersunk angle of 90° was specified for both types of screw, this being a departure from the previous international specification of tapping screws with an 80° angle. The performance of screws with a 90° angle was verified in a number of tests. Although the decision to introduce the ISO common head style as established in ISO 7721 was made in 1977, it took quite a long time for this style to be adopted in national standards since ISO 7721 was primarily concerned with reducing the variety of screw heads but not with specifying other properties of such screws. Thus, in 1987, several countries, among them Germany, proposed to reconsider the decision to introduce the ISO common head style for tapping screws, where it was found that the majority of member countries had already adopted the ISO head in their national standards. The responsible ISO Committee, therefore, agreed not to make any alterations to the 1983 version of ISO 7721.

Taking the international development into account, the responsible German committee came to the conclusion that adoption of the international specifications on countersunk head screws would be inevitable, and decided to issue national standards on countersunk head screws with ISO head, granting, however, an adequate transition period after which the relevant DIN Standards would be withdrawn.

The decision to adopt the ISO head was seen to be justified by the formation of CEN/TC 185, Fasteners, in 1989 since relevant European Standards dealing with such screws will be published shortly. Note that such EN Standards will be accepted only if they agree with existing ISO Standards, to avoid another transition and that the transition period mentioned on page 1 may be shorter if the EN Standards appear sooner than expected.

The following table, which compares the most essential head dimensions, d_k and k , of screws as specified in ISO 7047 and the present standard, is intended to make it easier for the user to see whether screws are interchangeable. The screws should be checked for interchangeability in cases where automatic feed and bolting systems are used.

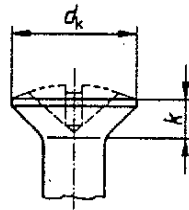

Table 3.

Values given in mm

Thread size (d)		M1,6	M2	M2,5	M3	M3,5	M4	M5	M6	M8	M10
d_k max.	ISO 7047	3	3,8	4,7	5,5	7,3	8,4	9,3	11,3	15,8	18,3
	DIN 966	3	3,8	4,7	5,6	6,5	7,5	9,2	11	14,5	18
k max.	ISO 7047	1	1,2	1,5	1,65	2,35	2,7	2,7	3,3	4,65	5
	DIN 966	0,96	1,2	1,5	1,65	1,93	2,2	2,5	3	4	5

Note. In order to facilitate the use of ISO 7721 countersunk head screws, a standard on mating countersinks, DIN 66, has been published.

International Patent Classification

F 16 B 35/04