

Hexagon thin castle nuts (previous design)

DIN 937

Kronenmuttern, niedrige Form (alte Ausführung)

Supersedes December 1978 edition

In keeping with current practice in standards published by the International Organization for Standardization (ISO), a comma has been used throughout as the decimal marker.

Hexagon castle nuts as specified in this standard should not be used for new designs. It is recommended that hexagon castle nuts specified in DIN 979 be used instead of hexagon castle nuts in accordance with this standard. For existing designs, hexagon castle nuts in accordance with this standard are only interchangeable with hexagon castle nuts specified in DIN 979 for sizes up to 14 mm nominal thread diameter.

Dimensions in mm

1 Field of application

This standard gives specifications for hexagon thin castle nuts with metric threads ranging from 6 to 52 mm nominal thread diameter, assigned to product grades A (up to and including 16 mm nominal thread diameter) and B (above 18 mm nominal thread diameter).

If, in special cases, nuts are to comply with specifications other than those listed in this standard, e.g. regarding property classes, they shall be selected in accordance with the appropriate standards.

2 Dimensions

Up to and including 10 mm nominal thread diameter

From 12 mm nominal thread diameter

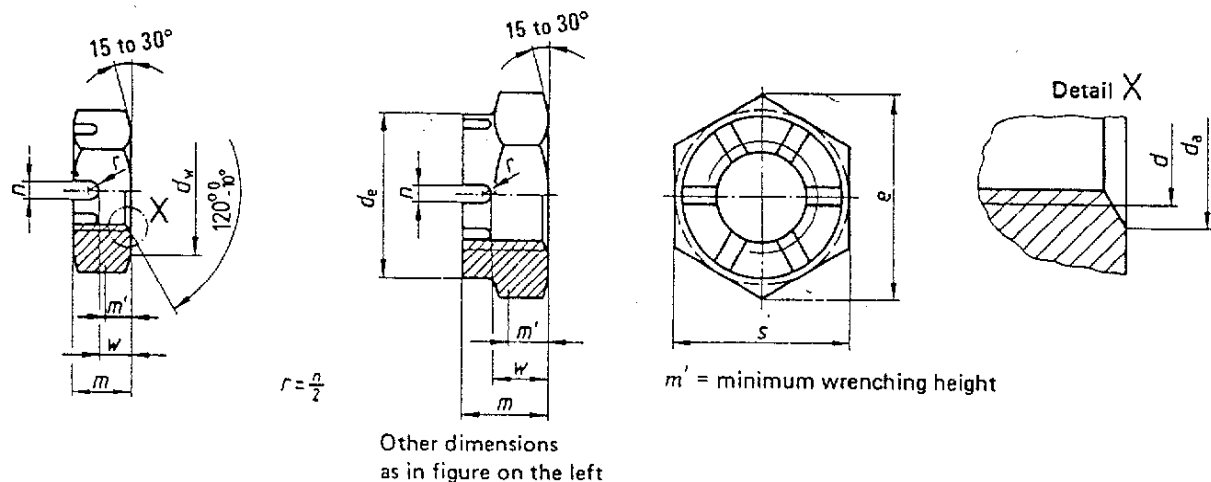

The bottom of the slots may be round, rounded or flat, at manufacturer's discretion. Hexagon thin castle nuts may be supplied with or without a thread in the slotted part, at manufacturer's discretion. The faces of the slotted parts may be rounded.

Continued on pages 2 to 4

Thread size <i>d</i>	M6	(M7)	M8	M10	M12	(M14)	M16	(M18)	M20	(M22)	
	—	—	M8X1	M10X1,25	M12X1,25	(M14X1,5)	M16X1,5	(M18X1,5)	M20X1,5	(M22X1,5)	
<i>P</i> 1)	1	1	1,25	1,5	1,75	2	2	(M18X2)	M20X2	(M22X2)	
<i>d_a</i>	min.	6	7	8	10	12	14	16	18	20	22
	max.	6,75	7,75	8,75	10,8	13	15,1	17,3	19,5	21,6	23,8
<i>d_e</i>	max.	—	—	—	—	17	19	22	25	28	30
	min.	—	—	—	—	16,57	18,48	21,48	24,3	27,3	29,3
<i>d_w</i> min.	8,8	9,5	11,3	15,3	17,2	20,2	22,2	24,8	27,7	29,5	
<i>e</i> min.	11,05	12,12	14,38	18,9	20,1	24,49	26,75	29,56	32,95	35,03	
<i>m</i>	max. ³⁾	6	7	8	9	10	11	12	13	13	15
	min.	5,7	6,64	7,64	8,64	9,64	10,57	11,57	12,3	12,3	14,3
<i>m'</i> min.	2,8	3,2	3,8	4,6	5,3	5,9	5,9	6,7	6,7	9,1	
<i>n</i>	min.	2	2	2,5	2,8	3,5	3,5	4,5	4,5	4,5	5,5
	max.	2,25	2,25	2,75	3,05	3,8	3,8	4,8	4,8	4,8	5,8
<i>s</i> nominal dimension	max. =	10	11	13	17	19	22	24	27	30	32
	min.	9,78	10,73	12,73	16,73	18,67	21,67	23,67	26,16	29,16	31
<i>w</i>	min.	3,2	3,7	4,2	4,7	5,7	6,64	6,64	7,64	7,64	8,64
	max.	3,5	4	4,5	5	6	7	7	8	8	9
Split pins in accordance with DIN 94 2)	1,6 X 14	1,6 X 14	2 X 16	2,5 X 20	3,2 X 22	3,2 X 25	4 X 28	4 X 32	4 X 36	5 X 36	

Thread size <i>d</i>	M 24	(M 27)	M 30	(M 33)	M36	(M 39)	M 42	(M 45)	M 48	(M 52)	
	M24X2	(M27X2)	M30X2	(M33X2)	M36X3	(M39X3)	M42X3	(M45X3)	M48X3	(M52X3)	
<i>P</i> 1)	3	3	3,5	3,5	4	4	4,5	4,5	5	5	
<i>d_a</i>	min.	24	27	30	33	36	39	42	45	48	52
	max.	25,9	29,2	32,4	35,6	38,9	42,1	45,4	48,6	51,8	56,2
<i>d_e</i>	max.	34	38	42	46	50	55	58	62	65	70
	min.	33	37	41	45	49	53,8	56,8	60,8	63,8	68,8
<i>d_w</i> min.	33,2	38	42,7	46,6	51,1	55,9	60,6	64,7	69,4	74,2	
<i>e</i> min.	39,55	45,20	50,85	55,37	60,79	66,44	72,02	76,95	82,60	88,25	
<i>m</i>	max. ³⁾	15	17	18	20	20	22	23	25	25	27
	min.	14,3	16,3	17,3	19,16	19,16	21,16	22,16	24,16	24,16	26,16
<i>m'</i> min.	9,1	8,7	8,7	10,3	10,3	11,9	11,9	13,5	13,5	15	
<i>n</i>	min.	5,5	5,5	7	7	7	7	9	9	9	
	max.	5,8	5,8	7,36	7,36	7,36	7,36	9,36	9,36	9,36	
<i>s</i> nominal dimension	max. =	36	41	46	50	55	60	65	70	75	80
	min.	35	40	45	49	53,8	58,8	63,8	68,1	73,1	78,1
<i>w</i>	min.	8,64	10,57	10,57	12,57	12,57	13,57	15,57	15,57	17,57	
	max.	9	11	11	13	13	13	14	16	16	
Split pins in accordance with DIN 94 2)	5 X 40	5 X 45	6,3 X 50	6,3 X 56	6,3 X 63	6,3 X 71	8 X 71	8 X 80	8 X 80	8 X 90	

Sizes in brackets shall be avoided if possible.

1) *P* = pitch of coarse thread in accordance with DIN 13 Part 12.

2) The lengths of the split pins given are guideline values.

3) = nominal dimension *m*.

Number of slots: up to 39 mm thread diameter: 6;
above 39 mm thread diameter: 8.

3 Technical delivery conditions

Material		Steel	Stainless steel	Nonferrous metal
General requirements		In accordance with DIN 267 Part 1.		
Thread	Tolerance	6H ²⁾		
	Standard	DIN 13 Part 12 and Part 15		
Mechanical properties	Property class (material)	14H 17H 22H	\leq M 20: A2-70; $>$ M 20 \leq M 39: A2-50; $>$ M 39: subject to agreement.	e.g. CU2, CU3
	Standard	DIN 267 Part 24 ¹⁾	DIN 267 Part 11	DIN 267 Part 18
Permissible dimensional deviations and deviations of form	Product grade	\leq M 16: A (previously m); $>$ M 16: B (previously mg).		
	Standard	DIN ISO 4759 Part 1.		
Surface		As processed. DIN 267 Part 2 (at present at the stage of draft) shall apply with regard to the peak-to-valley heights of the surfaces. DIN 267 Part 21 shall apply with regard to the widening test. DIN 267 Part 20 shall apply with regard to permissible surface irregularities. DIN 267 Part 9 ²⁾ shall apply with regard to electroplating. DIN 267 Part 10 shall apply with regard to hot-dip galvanizing.	Bright.	Bright.
Acceptance testing		DIN 267 Part 5 shall apply with regard to acceptance testing.		
<p>1) By way of departure from DIN 267 Part 24, a minimum hardness of 160 HV shall apply for nuts assigned to property class 17H.</p> <p>2) Applies to nuts with or without coating. 6H makes it possible for normal coating thicknesses to be applied in accordance with DIN 267 Part 9, but the reference line shall not be fallen short of. Depending on the coating thickness required, a larger fundamental deviation shall be selected than that assigned to the H position. A larger fundamental deviation might impair the resistance of the bolt/nut assembly to stripping.</p>				

4 Designation

Designation of an M12 hexagon castle nut, assigned to property class 17H:

Hexagon castle nut DIN 937 – M 12 – 17H

If product grade A is required for sizes over 16 mm thread diameter, this shall be indicated in the designation, e.g.:

Hexagon castle nut DIN 937 – M 20 – 17H – A

If it is intended supplying hexagon castle nuts from 12 to 39 mm thread diameter without shouldered slotted part, the symbol KK shall be added to the designation, e.g.:

Hexagon castle nut DIN 937 – M 20 – KK – 17H

DIN 962 shall apply with regard to the designation of designs and types of finish with additional data to be given when ordering.

Hexagon castle nuts made of free-cutting steel may only be supplied in accordance with this standard if the designation AU is added to the property class symbol, e.g.:

Hexagon castle nut DIN 937 – M 12 – 17H – AU

The DIN 4000 – 2 – 7 tabular layout for article characteristics shall apply for hexagon flat castle nuts conforming to this standard.

5 Masses

The values of mass given are guideline values. They shall apply to steel nuts.

Thread size <i>d</i>	M 6	M 7	M 8	M 10	M 12	M 14	M 16	M 18	M 20	M 22
Mass (7,85 kg/dm ³) kg per 1000 units ≈	2,5	3,4	5,4	11,3	14,7	17,9	22,7	33,2	41,1	49,8

Thread size <i>d</i>	M 24	M 27	M 30	M 33	M 36	M 39	M 42	M 45	M 48	M 52
Mass (7,85 kg/dm ³) kg per 1000 units ≈	67,8	103	133	173	215	269	310	406	463	580

For nuts with fine threads, approximately the same values of mass may be assumed.

Standards referred to

DIN 13 Part 12	ISO metric screw threads; coarse and fine threads from 1 to 300 mm diameter, selection of diameters and pitches
DIN 13 Part 15	ISO metric screw threads; fundamental deviations and tolerances for screw threads from 1 mm diameter
DIN 94	Split pins
DIN 267 Part 1	Fasteners; technical delivery conditions; general requirements
DIN 267 Part 2	(at present at the stage of draft) Fasteners; technical delivery conditions; types of finish and dimensional accuracy
DIN 267 Part 5	Fasteners; technical delivery conditions; acceptance testing
DIN 267 Part 9	Fasteners; technical delivery conditions; electroplated components
DIN 267 Part 10	Fasteners; technical delivery conditions; hot-dip galvanized parts
DIN 267 Part 11	Fasteners; technical delivery conditions with addenda to ISO 3506; components of stainless and acid-resistant steels
DIN 267 Part 18	Fasteners; technical delivery conditions; components made of non-ferrous metals
DIN 267 Part 20	Fasteners; technical delivery conditions; surface irregularities on nuts
DIN 267 Part 21	Fasteners; technical delivery conditions; widening test for nuts
DIN 267 Part 24	Fasteners; technical delivery conditions; property classes for nuts (hardness classes)
DIN 962	Bolts, screws, studs and nuts; designations, types and finishes
DIN 4000 Part 2	Tabular layouts of article characteristics for bolts, screws and nuts
DIN ISO 272	Fasteners; widths across flats for hexagon products
DIN ISO 4759 Part 1	Tolerances for fasteners; bolts, screws and nuts with thread diameters $\geq 1,6$ and ≤ 150 mm and product grades A, B and C

Previous editions

DIN Kr 754: 12.34, 09.36; DIN 937: 04.42, 03.54, 05.56, 09.59, 06.63, 11.76, 12.78

Amendments

Compared with the December 1978 edition, the following amendments have been made:
The content of the standard has been revised and harmonized with other DIN Standards on hexagon castle nuts and hexagon nuts.

Explanatory notes

See DIN 935 Part 1.

International Patent Classification

F 16 B 37/00