

UDC 621.882.32

October 1987

Hexagon slotted nuts with metric coarse pitch thread

Product grade C

DIN
935
Part 3

Kronenmuttern; metrisches Regelgewinde; Produktklasse C

Supersedes December 1983 edition.

In keeping with current practice in standards published by the International Organization for Standardization (ISO), a comma has been used throughout as the decimal marker.

The new widths across flats 16 mm, 18 mm, 21 mm and 34 mm as specified in ISO 272 shall be used instead of the previous widths across flats 17 mm, 19 mm, 22 mm and 32 mm for thread sizes M 10, M 12, M 14 and M 22; see example of designation in clause 4.

It is intended to omit the obsolescent widths across flats by 1 July 1992 at the latest. In this standard, this applies to width across flats 19 mm specified for M 12.

Dimensions in mm

1 Field of application

This standard specifies requirements for M 12 to M 33 hexagon slotted nuts, assigned to product grade C.

If, in special cases, nuts are to comply with specifications other than those given in this standard, e.g. regarding property class, they shall be selected in accordance with the relevant standards.

2 Dimensions

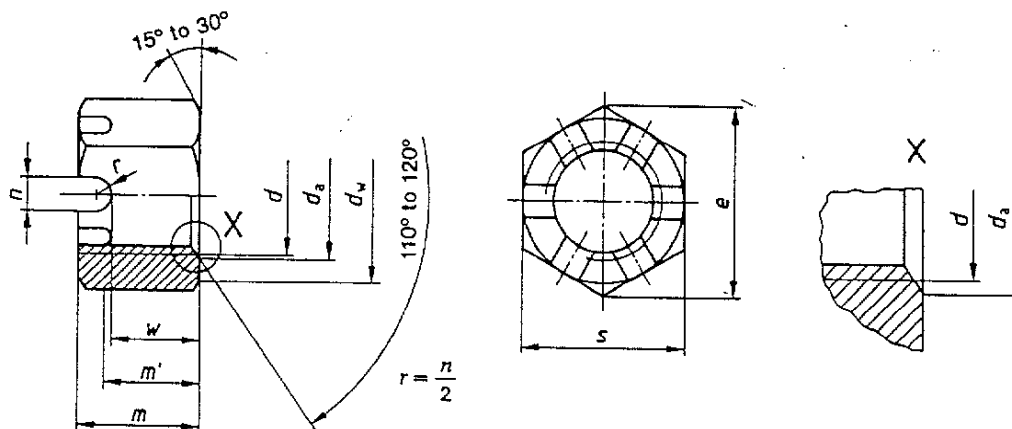

m' = minimum wrenching height.

The bottom of the slots, at the manufacturer's discretion, may be rounded or chamfered. Hexagon slotted nuts may be supplied with the slotted part threaded or unthreaded.

Continued on pages 2 to 4

Page 2 DIN 935 Part 3

Thread size (d)	M 12	M 16	M 20	M 24	(M 27)	M 30	(M 33)
$P^1)$	1,75	2	2,5	3	3	3,5	3,5
d_a min.	12	16	20	24	27	30	33
d_a max.	13	17,3	21,6	25,9	29,2	32,4	35,6
d_w min.	16,1	17	21,7	27,7	33,2	38	46,6
e min.	19,85	20,88	26,17	32,95	39,55	45,2	50,85
m max. = nominal size	15	19	22	27	30	33	35
m min.	13,2	16,9	19,9	24,9	27,9	30,5	32,5
m' min.	10,6	13,5	15,9	19,9	22,3	24,4	26
n min.	3,5	4,5	4,5	5,5	5,5	7	7
n max.	3,98	4,98	4,98	5,98	5,98	7,58	7,58
s max. = nominal size	18	19	24	30	36	41	50
s min.	17,57	18,48	23,16	29,16	35	40	49
w min.	9,48	12,3	15,3	18,16	21,16	23,16	25,16
w max.	10	13	16	19	22	24	26
Split pin as in DIN 94 ²⁾	3,2 × 22	4 × 28	4 × 36	5 × 40	5 × 45	6,3 × 50	6,3 × 56

Sizes in brackets should be avoided where possible.

1) P = pitch of thread.

2) The split pin lengths have been given for guidance only.

Number of slots: 6.

3 Technical delivery conditions

Material	Steel	
General requirements	As specified in DIN 267 Part 1.	
Thread	Tolerance	7H ¹⁾
	As specified in	DIN 13 Parts 12 and 15.
Mechanical properties	Property class (material)	For sizes up to M16: 5; for larger sizes : 4.
	As specified in	ISO 898 Part 2.
Limit deviations, geometrical tolerances	Product grade	C
	As specified in	ISO 4759 Part 1.
Surface finish	DIN 267 Part 2 shall apply with regard to surface roughness. DIN 267 Part 21 shall apply with regard to the widening test. DIN 267 Part 9 shall apply with regard to electroplating. ¹⁾ DIN 267 Part 10 shall apply with regard to hot dip galvanizing.	
Acceptance inspection	DIN 267 Part 5 shall apply with regard to acceptance inspection.	

¹⁾ Where a protective coating is applied, e.g. an electroplated coating complying with DIN 267 Part 9, depending on the coating thickness required, it may be necessary, particularly in the case of tolerance class 7H nuts, to select a larger fundamental deviation than that assigned to the H position (see DIN 267 Part 9). This, however, might impair the resistance of the bolt/nut assembly to stripping.

4 Designation

Designation of an M20 hexagon slotted nut assigned to property class 4:

Hexagon slotted nut DIN 935 – M 20 – 4

This designation signifies that the width across flats for size M 12 is that hitherto specified, viz. 19 mm. If the nuts are to be supplied with the new width across flats, 18 mm, as specified in ISO 272, the width across flats (SW18) shall be included in the designation, e.g.:

Hexagon slotted nut DIN 935 – M 12 – SW18 – 5

The DIN 4000–2–7 tabular layout of article characteristics shall apply for nuts covered in this standard.

5 Mass

The values of mass given for steel nuts are for guidance only.

Thread size (<i>d</i>)	M 12		M 16	M 20	M 24	M 27	M 30	M 33
Mass (7,85 kg/dm ³) per 1000 units, in kg, ≈	–	25	44	82	142	208	295	352

Standards referred to

DIN 13 Part 12	ISO metric screw threads; coarse and fine pitch threads with diameters from 1 to 300 mm; selection of diameters and pitches
DIN 13 Part 15	ISO metric screw threads; fundamental deviations and tolerances for screw threads of 1 mm diameter and larger
DIN 94	Split pins
DIN 267 Part 1	Fasteners; technical delivery conditions; general requirements
DIN 267 Part 2	Fasteners; technical delivery conditions; types of finish and dimensional accuracy
DIN 267 Part 5	Fasteners; technical delivery conditions; acceptance inspection (modified version of ISO 3269, 1984 edition)
DIN 267 Part 9	Fasteners; technical delivery conditions; electroplated components
DIN 267 Part 10	Fasteners; technical delivery conditions; hot dip galvanized components
DIN 267 Part 21	Fasteners; technical delivery conditions; widening test for nuts
DIN 4000 Part 2	Tabular layout of article characteristics for bolts, screws and nuts
ISO 272	Fasteners; hexagon products, widths across flats
ISO 898 Part 2	Mechanical properties of fasteners; nuts with specified proof load values
ISO 4759 Part 1	Tolerances for fasteners; bolts, screws and nuts with thread diameters $\geq 1,6$ and ≤ 150 mm; product grades A, B and C

Previous editions

DIN Kr 753: 12.34, 09.36; DIN 533 Part 1: 01.41, 09.59, 06.63; DIN 534 Part 1: 01.41x, 06.63; DIN 935: 05.68, 04.77; DIN 935 Part 1: 01.26, 04.34, 06.37, 04.42x, 02.54, 05.56, 06.63; DIN 935 Part 3: 12.83.

Amendments

In comparison with the December 1983 edition, a note on the period of validity of the previous widths across flats has been included.

Explanatory notes

For more than 20 years efforts have been directed towards the achievement of the international interchangeability of fasteners by preparing international standards for the product concerned. ISO Standards have now been published for the most important types of fasteners (see ISO Standards Handbook 18).

However, international efforts only serve a useful purpose if national standards are adapted as far as possible to International standards, or, ideally, replaced by them. Current DIN Standards already agree in substance with the relevant ISO Standards, but still differ in some respects, as for instance in the widths across flats for hexagon products.

The Federal Republic of Germany adopted International Standard ISO 272 on widths across flats as national standard DIN ISO 272 in October 1979. Nevertheless, widths across flats deviating from DIN ISO 272 are still being used in Germany for nominal sizes M 10, M 12, M 14 and M 22. The table below compares the previous widths across flats with the new ones specified for the four nominal sizes referred to.

Thread size	M 10	M 12	M 14	M 22
Previous width across flats, in mm	17	19	22	32
New width across flats as in ISO 272, in mm	16	18	21	34

The manufacturers and users of hexagon products participating in the work of the *Normenausschuß Mechanische Verbindungselemente* (Fasteners Standards Committee), together with representatives of the dealers in fasteners, have decided to introduce the new widths across flats in all relevant product standards. Since experience has shown, that the introduction of the new widths across flats has not been advanced by their inclusion in DIN Standards merely as preferred alternatives to the previous widths across flats, the following decisions have been reached to accelerate the changeover procedure.

Supplementary to current DIN Standards specifying the previous widths across flats, DIN ISO Standards dealing with the same products will, wherever ISO Standards are

available, be published which, besides introducing a number of other minor amendments, will specify the new widths across flats conforming to ISO 272. In both DIN and DIN ISO Standards attention will be drawn to the fact that the relevant ISO Standards are to be preferred and that the DIN Standard is to be replaced after a transition period of 5 years.

If no relevant ISO Standard is available, the DIN Standard will contain a foreword stating that the previous width across flats specifications are to be withdrawn after a transition period of 5 years and replaced by those specified in ISO 272.

This sets a time limit for both manufacturer and user of hexagon products by which the changeover to the new widths across flats must be effected. The responsible committee is of the opinion, that it will still be possible after this period to obtain fasteners complying with the superseded specifications as spare parts.

In some cases, the replacement of the previous DIN Standards by the relevant ISO Standards will have further consequences, besides the changeover to the new widths across flats, attention being drawn to this circumstance in the national foreword of the relevant DIN ISO Standards. These consequences result from the fact that the ISO Standards have not yet reached the same level of completeness as the DIN Standards. Thus a number of nominal sizes, as well as several product specifications for fine pitch threads are not found in the ISO product standards. Furthermore, ISO Standards on technical delivery conditions are still in the initial stages, so that specific requirements are still subject to separate agreement when ordering products in accordance with ISO Standards, as they are not included in the designation for order purposes.

Besides these consequences, which are of importance when applying the new ISO Standards, the amendment of the widths across flats also has a number of consequences as regards the use of the new products which the designer must take into consideration. Besides the amended assembly sizes, this applies above all to the different surface pressure for the bearing area of the nut or the heads of the bolts. These difficulties are discussed in Recommendation VDA 262*) published by the *Verband der Automobilindustrie e.V.* (German Automobile Manufacturers Association).

International Patent Classification

F 16 B 35/00

*) Obtainable from: *Dokumentation Kraftfahrwesen e.V.*, Grönerstraße 5, D-7140 Ludwigsburg.