

UDC 621.882.219.093 : 621.882.211

June 1983

Hexagon head pipe plugs

DIN
909

Verschlusschrauben mit Aussensechskant; kegeliges Gewinde

Supersedes January 1973 edition

As it is current practice in standards published by the International Organization for Standardization (ISO), the comma has been used throughout as a decimal marker.

Dimensions in mm

1 Field of application

Pipe plugs in accordance with this standard can be used to occlude holes with a parallel internal screw thread in accordance with DIN 13 Part 12, DIN 158, DIN 3858 and DIN ISO 228 Part 1. Depending on the medium, the pressure, the temperature and the combination of materials, there is no guarantee of leak tightness. Consequently, the use of an appropriate sealant is recommended, depending on the application concerned. This applies in particular to the sealing of holes with an internal screw thread in accordance with DIN 13 Part 12.

Note. Pipe plugs in accordance with this standard shall not be used for gas and drinking water pipelines.

2 Dimensions, designation

up to 18 mm nominal screw thread diameter

from 20 mm nominal screw thread diameter

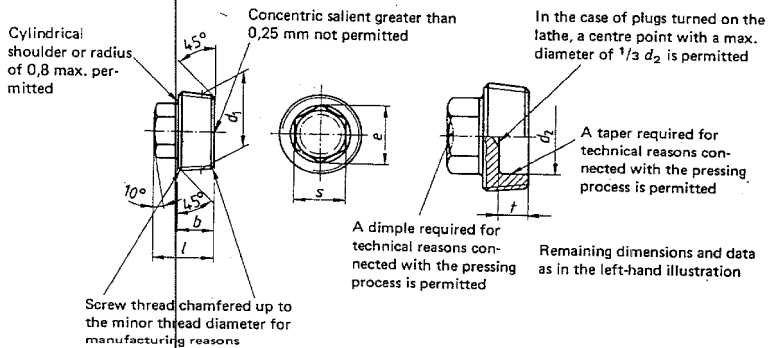
Designation of a steel (St) pipe plug with tapered thread $d_1 = M 20 \times 1,5$:

Pipe plug DIN 909 - M 20 x 1,5 - St

Designation of a steel (St) pipe plug with tapered thread $d_1 = R 1/2$:

Pipe plug DIN 909 - R 1/2 - St

Continued on pages 2 to 4

Page 2 DIN 909

| d_1 Metric tapered external screw thread in accordance with DIN 158 Short type | | Whitworth pipe thread in accordance with DIN 3858 Tolerance position 2 (Short type) | b h16 | d_2 +1 0 | e min. | l h16 | s Par. dev.*) | t o -1 | Weight (7,85 kg/dm ³) kg/1000 pieces ≈ |
|--|----------|--|------------|------------------|-------------|------------|-----------------------|----------------|---|
| M 10 X 1 | — | R 1/8 | 8 | — | 7,74 | 12,5 | 7 | — | 5,72 |
| M 12 X 1,5 | — | — | 10 | — | 7,74 | 15 | 7 | — | 9,10 |
| — | — | R 1/4 | 10 | — | 9,76 | 15 | 9 | — | 12,0 |
| M 14 X 1,5 | — | — | 10 | — | 9,76 | 15 | 9 | — | 13,2 |
| M 16 X 1,5 | — | — | 10 | — | 10,89 | 16 | 10 | — | 17,9 |
| — | — | R 3/8 | 10 | — | 10,89 | 16 | 10 | — | 19,4 |
| M 18 X 1,5 | — | — | 10 | — | 10,89 | 16 | 10 | — | 21,9 |
| M 20 X 1,5 | — | — | 10 | 12 | 14,20 | 17 | 13 | 6 | 25,0 |
| — | — | R 1/2 | 10 | 12 | 14,20 | 17 | 13 | 6 | 27,2 |
| M 22 X 1,5 | — | — | 10 | 14 | 14,20 | 17 | 13 | 6 | 29,0 |
| M 24 X 1,5 | — | — | 12 | 16 | 18,72 | 20 | 17 | 7 | 43,8 |
| M 26 X 1,5 | — | — | 12 | 16 | 18,72 | 20 | 17 | 7 | 50,9 |
| — | M 27 X 2 | R 3/4 | 12 | 16 | 18,72 | 20 | 17 | 7 | 51,8 |
| M 30 X 1,5 | M 30 X 2 | — | 12 | 20 | 20,88 | 22 | 19 | 7 | 69,4 |
| — | M 33 X 2 | R 1 | 12 | 23 | 20,88 | 22 | 19 | 7 | 76,2 |
| M 36 X 1,5 | M 36 X 2 | — | 15 | 26 | 26,17 | 27 | 24 | 10 | 118 |
| (M 38 X 1,5) | — | — | 15 | 28 | 26,17 | 27 | 24 | 10 | 125 |
| — | M 39 X 2 | — | 15 | 28 | 26,17 | 27 | 24 | 10 | 130 |
| M 42 X 1,5 | M 42 X 2 | R 1 1/4 | 18 | 32 | 26,17 | 30 | 24 | 13 | 151 |
| M 45 X 1,5 | M 45 X 2 | — | 18 | 35 | 26,17 | 30 | 24 | 13 | 163 |
| M 48 X 1,5 | M 48 X 2 | R 1 1/2 | 20 | 38 | 32,95 | 35 | 30 | 15 | 230 |
| M 52 X 1,5 | M 52 X 2 | — | 20 | 42 | 32,95 | 35 | 30 | 15 | 249 |
| — | M 56 X 2 | — | 22 | 46 | 32,95 | 37 | 30 | 17 | 275 |
| — | M 60 X 2 | — | 22 | 50 | 32,95 | 37 | 30 | 17 | 296 |

*) Per. dev. = permissible deviation

3 Material

St = 9 SMnPb 28 K in accordance with DIN 1651 or } at manufacturer's discretion 1)
 UQSt 36 in accordance with DIN 17 111

A1 = Stainless steel in accordance with DIN 267 Part 11

Al-Leg = Aluminium alloy in accordance with DIN 267 Part 18

CuZn = Copper-zinc alloy in accordance with DIN 267 Part 18

PA = Polyamide

Other materials or specific material qualities subject to agreement.

4 Finish

Product class B (previously type mg) in accordance with DIN ISO 4759 Part 1

Surface peak-to-valley heights in accordance with DIN 267 Part 2 (at present at the stage of draft)

General tolerances: DIN 7168 - g.

1) These materials are valid in lieu of property class 5.8 in accordance with DIN ISO 898 Part 1, which was specified in previous editions of this standard.

5 Surface protection

If surface protection is required, the following specifications shall apply:

- DIN 267 Part 9 for galvanic surface protection
- DIN 50 942 for phosphate coatings

Other kinds of surface protection subject to agreement.

6 General requirements

As regards general requirements, DIN 267 Part 1 shall apply.

7 Acceptance test

DIN 267 Part 5 (at present at the stage of draft) shall apply to the acceptance test.

Standards referred to

| | | |
|---------|-------------|---|
| DIN | 13 Part 12 | ISO metric screw threads; coarse and fine threads from 1 to 300 mm diameter, selection of diameters and pitches |
| DIN | 158 | Metric tapered external screw threads, with mating parallel internal screw threads; nominal dimensions and permissible deviations |
| DIN | 267 Part 1 | Fasteners; technical delivery conditions, general requirements |
| DIN | 267 Part 2 | (at present at the stage of draft) Fasteners; technical delivery conditions, finish and dimensional accuracy |
| DIN | 267 Part 5 | (at present at the stage of draft) Fasteners; technical delivery conditions, acceptance test |
| DIN | 267 Part 9 | Fasteners; technical delivery conditions, components with electroplated coatings |
| DIN | 267 Part 11 | Fasteners; technical delivery conditions with additions to ISO 3506; stainless and acid-resistant steel components |
| DIN | 267 Part 18 | Fasteners; technical delivery conditions, non-ferrous metal components |
| DIN | 1651 | Free cutting steels; technical delivery conditions |
| DIN | 3858 | Whitworth pipe threads; parallel internal thread and tapered external thread for pipe unions |
| DIN | 7168 Part 1 | General tolerances; linear and angular dimensions |
| DIN | 17 111 | Low carbon unalloyed steels for bolts, nuts and rivets; technical delivery conditions |
| DIN | 50 942 | Phosphating of metals; process principles, symbols and test methods |
| DIN ISO | 228 Part 1 | Pipe threads where pressure-tight joints are not made on the threads; designation, dimensions and tolerances |
| DIN ISO | 898 Part 1 | Mechanical properties of fasteners; bolts, screws and studs |
| DIN ISO | 4759 Part 1 | Fasteners; tolerances for bolts, screws and nuts with screw thread diameters from 1,6 to 150 mm; product classes A, B and C |

Other relevant standards

| | | |
|-----|------------|--|
| DIN | 906 | Hexagon socket pipe plugs |
| DIN | 907 | Core plugs and core plug bars with parallel screw thread |
| DIN | 908 | Hexagon socket screw plugs with parallel screw thread |
| DIN | 910 Part 1 | Heavy duty hexagon head screw plugs with shoulder and parallel screw thread |
| DIN | 910 Part 2 | Heavy duty hexagon head screw plugs with shoulder, vent hole and parallel screw thread |
| DIN | 7604 | Light duty hexagon head screw plugs with parallel screw thread |

Previous editions

DIN 909: 12.43, 04.56, 01.73

Amendments

The following amendments have been made in comparison with the January 1973 edition:

- a) The contents of the standard have been revised editorially. A new clause "Field of application" has been inserted at the beginning.
 - b) The permissible deviations in accordance with DIN 267 Part 2 or DIN ISO 4759 Part 1 have been incorporated in addition to the individual dimensions of the pipe plugs.
 - c) The material specifications have been extended; symbols have been adopted.
- d) For sizes M 20 X 1,5, M 22 X 1,5 and R 1/2, the width across flats has been changed from 12 mm to 13 mm (improved tightening conditions).

Page 4 DIN 909

Explanatory notes

For some sizes of pipe plugs, two different thread pitches have been listed, as previously, such as M 30 X 1,5 and M 30 X 2. It is however advisable to select the coarser of the two pitches in each case, if the prevailing design conditions allow it.

The previously featured property class 5.8 in accordance with DIN ISO 898 Part 1 (previously DIN 267 Part 3) has been dropped. Property classes in accordance with the above-mentioned standard are intended primarily for bolts subjected to tensile stress, and they specify the corresponding mechanical properties and the valid test procedures applicable to these properties. In the case of pipe plugs subjected to compressive stress, these properties are neither relevant nor verifiable. The specification of hardness categories in accordance with DIN ISO 898 Part 2 has also been dropped from the present standard. Depending on the manufacturing process, the degree of shaping and the measuring point, the hardness of pipe plugs can vary quite considerably, and consequently it does not constitute a valid criterion for the assessment of the mechanical properties. It has however been allowed to continue referring to property class 5.8 on existing drawings and documents for the time being.

International Patent Classification

B 65 D 39-08

B 65 D 41-04

B 65 D 41-34