

UDC 621.884.091.4

May 1993

## Mushroom head rivets with nominal diameters from 1,6 to 6 mm

# DIN 674

Flachrundniete; Nenndurchmesser 1,6 bis 6 mm

Supersedes July 1977 edition.

*In keeping with current practice in standards published by the International Organization for Standardization (ISO), a comma has been used throughout as the decimal marker.*

Dimensions in mm

### 1 Scope and field of application

This standard specifies dimensions of steel and nonferrous metal mushroom head rivets with nominal diameters from 1,6 to 6 mm.

### 2 Dimensions

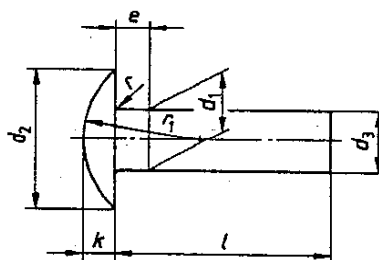

Table 1: Dimensions and mass

$d_1$	Nominal size	(1,4)	1,6	2	2,5	3	(3,5)	4	5	6
	Limit deviations	$\pm 0,05$			$\pm 0,1$				$\pm 0,15$	
$d_2$	Nominal size	3,2	3,6	4,5	5,6	6,8	7,8	9	11,2	13,5
	Tolerance	h14					h15			
$d_3$	min.	1,33	1,52	1,87	2,37	2,87	3,37	3,87	4,82	5,82
$e$	max.	0,7	0,8	1	1,25	1,5	1,75	2	2,5	3
$k$	js14	0,7	0,8	1	1,3	1,5	1,8	2	2,5	3
$r$	max.	0,2					0,3			0,4
$r_1$	$\approx$	2,8	3	3,6	4,2	5,4	6,1	7,1	8,8	10,7
$l$		Approximate mass (7,85 kg/dm <sup>3</sup> ), per 1000 units, in kg <sup>1</sup> )								
Nominal size	Limit deviations									
3	$+0,25$ 0	0,065	0,102	0,176						
4	$+0,30$ 0	0,077	0,118	0,201	0,353	0,568				
5		0,089	0,133	0,225	0,392	0,624				
6		0,102	0,149	0,250	0,430	0,679	1,01	1,40		

For <sup>1</sup>), see page 2.

(continued)

Continued on pages 2 to 5

Table 1 (concluded)

$d_1$	Nominal size	(1,4)	1,6	2	2,5	3	(3,5)	4	5	6										
	Limit deviations	± 0,05			± 0,1				± 0,15											
$d_2$	Nominal size	3,2	3,6	4,5	5,6	6,8	7,8	9	11,2	13,5										
	Tolerance	h14					h15													
$d_3$	min.	1,33	1,52	1,87	2,37	2,87	3,37	3,87	4,82	5,82										
$e$	max.	0,7	0,8	1	1,25	1,5	1,75	2	2,5	3										
$k$	js14	0,7	0,8	1	1,3	1,5	1,8	2	2,5	3										
$r$	max.	0,2					0,3			0,4										
$r_1$	≈	2,8	3	3,6	4,2	5,4	6,1	7,1	8,8	10,7										
Nominal size	$l$ Limit deviations	Approximate mass (7,85 kg/dm <sup>3</sup> ), per 1000 units, in kg <sup>1)</sup>																		
		8	+0,38 0	0,181	0,299	0,507	0,790	1,16	1,60	2,77	4,51									
		10		0,349	0,584	0,901	1,32	1,80	3,08	4,95										
		12			0,661	1,01	1,47	2,00	3,39	5,40										
		14	+0,43 0			1,12	1,62	2,19	3,69	5,84										
		16				1,23	1,77	2,39	4,00	6,27										
		18						2,58	4,31	6,73										
		20						2,78	4,62	7,17										
		22							4,93	7,62										
		25	+0,52 0						5,39	8,29										
		28								8,95										
		30								9,39										
<p>Lengths above 30 mm shall be graded in 5 mm steps.                      Use of sizes given in brackets and of intermediate lengths should be avoided where possible.                      Rivets are normally manufactured in the sizes for which values of mass have been specified.                      The values of mass specified are for guidance only.</p>																				
<p>1) Conversion factors for values of mass</p> <table border="1"> <thead> <tr> <th>Material</th> <th>St</th> <th>Cu</th> <th>Cu-Zn</th> <th>Al</th> </tr> </thead> <tbody> <tr> <td>Conversion factor</td> <td>1</td> <td>1,134</td> <td>1,070</td> <td>0,344</td> </tr> </tbody> </table>											Material	St	Cu	Cu-Zn	Al	Conversion factor	1	1,134	1,070	0,344
Material	St	Cu	Cu-Zn	Al																
Conversion factor	1	1,134	1,070	0,344																

### 3 Technical delivery conditions

Table 2: Technical delivery conditions

Material <sup>1)</sup>	Steel	Nonferrous metal		
	St = QSt 32-3 or QSt 36-3, at the manufacturer's discretion.	CuZn = CuZn37	Cu = SF-Cu	Al = Al99,5
Minimum tensile strength, $R_m$ , in N/mm <sup>2</sup>	290	290	200	100
As specified in	DIN 1654 Part 2	DIN 17 677 Part 1	DIN 17 677 Part 1	DIN 1790 Part 1
Dimensional and geometrical tolerances	As specified in DIN 101.			
Surface finish	Standard finish: bright. Where a protective coating is required (e.g. an electroplated coating complying with ISO 4042), this shall be agreed when ordering. The tolerances and limit deviations specified in table 1 shall also apply after coating.			
Testing of mechanical properties	As specified in DIN 101.			
Acceptance inspection	As specified in DIN 101.			
1) Use of other materials shall be the subject of agreement.				

### 4 Designation

Designation of a steel (St) mushroom head rivet with a nominal diameter,  $d_1$ , of 4 mm and a length,  $l$ , of 8 mm:

Rivet DIN 674 - 4 × 8 - St

The DIN 4000-9-3 tabular layout of article characteristics shall apply to rivets as covered in this standard.

### 5 Examples of application

Table 3 specifies hole diameters and gives guide values for upset head dimensions and maximum grip lengths of both round head (A) and countersunk head (B) rivets.

#### Type A, upset head rounded

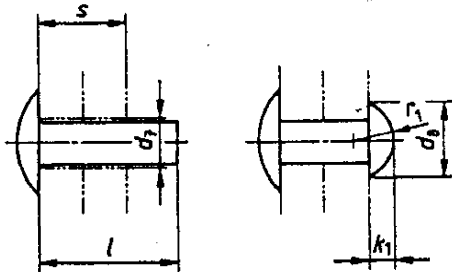

#### Type B, upset head countersunk

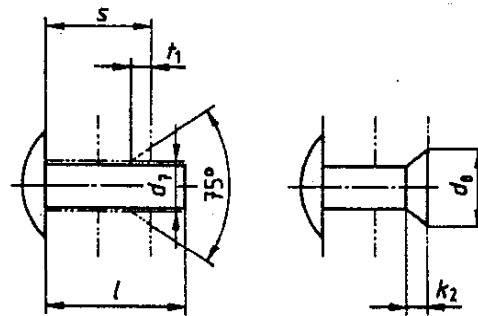

**Table 3: Hole diameters and guide values for upset head dimensions and grip lengths**

$d_1$	(1,4)	1,6	2	2,5	3	(3,5)	4	5	6									
$d_7$ H12	1,45	1,65	2,1	2,6	3,1	3,6	4,2	5,2	6,3									
Round head (A)	$d_8$	2,4	2,8	3,5	4,4	5,2	6,2	7	8,8	10,5								
	$k_1$	0,8	1	1,2	1,5	1,8	2,1	2,4	3	3,6								
	$r_1 \approx$	1,4	1,6	1,9	2,4	2,8	3,4	3,8	4,6	5,7								
Counter-sunk head (B)	$d_8$	2,4	2,8	3,5	4,4	5,2	6,2	7	8,8	10,5								
	$k_2$	0,6	0,7	0,8	1	1,3	1,4	1,9	2,4	2,8								
	$t_1 \approx$	0,6	0,7	0,8	1	1,3	1,4	1,8	2,3	2,7								
$l$	Maximum grip length, $s_{max}$																	
	A	B	A	B	A	B	A	B	A	B	A	B	A	B	A	B	A	B
3	1	1,5	1	1,5	—	1,5												
4	2	2,5	2	2,5	1,5	2,5	1	2	1	2								
5	2,5	3	2,5	3	2	3	2	3	1,5	2,5								
6	3	3,5	3	3,5	2,5	3,5	2,5	3,5	2,5	3,5	2,5	3,5	1,5	3,5				
8			5	6	4	5	4	5	4	5	4	5	3	5	2,5	4,5	1	3
10					6	7	6	7	6	7	6	7	5	7	4	6	3	5
12							8	9	8	9	8	9	7	9	6	8	5	7
14									10	11	10	11	9	11	8	10	7	9
16									12	13	12	13	11	13	10	12	9	11
18													12,5	14,5	11,5	13,5	10,5	12,5
20													14	16	13	15	12	14
22															14,5	16,5	13,5	15,5
25															17	19	16	18
28																	18	20
30																	20	22

Since the grip lengths specified are for guidance only, trial riveting is recommended, especially if automated procedures are used.

**Other relevant standards**

DIN 101	Rivets; technical delivery conditions
DIN 1654 Part 2	Cold heading and cold extruding steel; technical delivery conditions for killed unalloyed steel not intended for heat treatment
DIN 1790 Part 1	Wrought aluminium and aluminium alloy wire; properties
DIN 4000 Part 9	Tabular layout of article characteristics for bolts, pins, rivets, split pins and keys
DIN 17 677 Part 1	Wrought copper and copper alloy wire; properties
ISO 4042:1989	Threaded components; electroplated coatings

**Previous editions**

DIN 674: 10.26, 12.50, 12.53, 07.77.

**Amendments**

The following amendments have been made to the July 1977 edition.

- a) Clauses 2 to 7 have been replaced by clause 3 'Technical delivery conditions'.
- b) The specifications for materials have been amended.
- c) The minimum tensile strength,  $R_m$ , has been amended.
- d) It is now permitted to use the symbol Cu as a substitute for SF-Cu.
- e) Appendix A is no longer included.
- f) The standard has been editorially revised.

**International Patent Classification**

F 16 B 019/04