

Round nuts with set pin holes in side

DIN
548

Kreuzlochmuttern

Supersedes November 1970 edition.

In keeping with current practice in standards published by the International Organization for Standardization (ISO), a comma has been used throughout as the decimal marker.

Dimensions in mm

1 Scope and field of application

Round nuts with set pin holes in side are parts generally made of steel, stainless steel or non-ferrous metals, which are designed to be used for various purposes, as for instance in electrical engineering. They can be tightened by means of a type B hook wrench as specified in DIN 1810 and are intended to be used for locking components where no specific pre-stressing forces or a specific resistance to stripping are required.

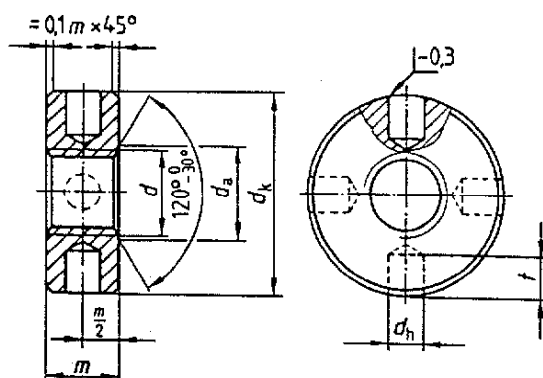
2 Dimensions

Thread size d	M 2	M 2,5	M 3	(M 3,5)	M 4	M 5	M 6	M 8	M 10
P ¹⁾	0,4	0,45	0,5	0,6	0,7	0,8	1	1,25	1,5
d_a	min.	2	2,5	3	3,5	4	5	6	10
	max.	2,3	2,9	3,45	4	4,6	5,75	6,75	10,8
d_h	min. = nominal size	1	1,2	1,5	1,5	1,5	2	2,5	3,5
	max.	1,14	1,34	1,64	1,64	1,64	2,14	2,64	3,68
d_k	max. = nominal size	5,5	7	8	9	10	12	14	22
	min.	5,2	6,64	7,64	8,64	9,64	11,57	13,57	21,48
m	max. = nominal size	2	2,2	2,5	3	3,5	4,2	5	8
	min.	1,75	1,95	2,25	2,75	3,2	3,9	4,7	7,64
t	min.	1	1,3	1,3	1,8	1,8	2,3	2,8	3,8
	max.	1,4	1,7	1,7	2,2	2,2	2,7	3,2	4,3
Mass (7,85 kg/dm ³), in kg per 1000 units, approximately	0,31	0,55	0,79	1,21	1,78	2,96	4,7	9,95	18,7

Size M 3,5 given in brackets should be avoided if possible.

¹⁾ P = pitch of thread (coarse pitch thread).

Continued on pages 2 and 3

3 Technical delivery conditions

Material		Steel	Stainless steel	Non-ferrous metal
General requirements		As specified in DIN 267 Part 1.		
Thread	Tolerance class	6H		
	Standard	DIN 13 Part 15		
Mechanical properties ³⁾	Property class (material)	St = steel ¹⁾	A1-50 C4-50	CuZn = copper-zinc alloy ²⁾
	Standard	DIN 1651	DIN 267 Part 11	DIN 267 Part 18
Permissible dimensional deviations and deviations of form	Product grade	A ⁴⁾		
	Standard	ISO 4759 Part 1		
Surface finish		As processed.	Bright.	Bright.
		DIN 267 Part 20 shall apply with regard to permissible surface discontinuities. DIN 267 Part 9 shall apply with regard to electroplating. DIN 50942 shall apply with regard to phosphating of metals.		
Acceptance inspection		DIN 267 Part 5 shall apply with regard to acceptance inspection ⁵⁾ .		
<p>1) St=9 SMnPb 28 K as specified in DIN 1651 or an equivalent steel in terms of strength. This material shall also be used in cases where property class 5 is given in existing documentation.</p> <p>2) CuZn = CU2 or CU3 (as specified in DIN 267 Part 18), at the manufacturer's discretion.</p> <p>3) Other property classes or materials shall be subject to agreement.</p> <p>4) R_z 25 shall apply for the surface roughness, R_z 16 for thread flanks of sizes not exceeding M 5, R_z 40 for thread flanks of sizes exceeding M 5.</p> <p>5) AQL (acceptable quality level) 1 shall apply for major characteristics and AQL 1,5 for minor characteristics, thread size d and hole diameter d_h being regarded as major characteristics, external diameter d_k, height of the nut, m, and depth of the hole, t, as minor characteristics.</p>				

4 Designation

Designation of an M5 round nut with set pin hole in side, made of steel (St):

Round nut DIN 548 – M5 – St

The DIN 4000 – 2 – 7 tabular layout of article characteristics shall apply for round nuts with set pin holes in side.

Standards referred to

- DIN 13 Part 15 ISO metric screw threads; fundamental deviations and tolerances for screw threads of 1 mm and larger
- DIN 267 Part 1 Fasteners; technical delivery conditions; general requirements
- DIN 267 Part 5 Fasteners; technical delivery conditions; acceptance inspection (modified version of ISO 3269, 1984 edition)
- DIN 267 Part 9 Fasteners; technical delivery conditions; components with electroplated coatings
- DIN 267 Part 11 Fasteners; technical delivery conditions (with additions to ISO 3506); corrosion-resistant stainless steel fasteners
- DIN 267 Part 18 Fasteners; technical delivery conditions; components made of non-ferrous metals
- DIN 267 Part 20 Fasteners; technical delivery conditions; surface discontinuities on nuts
- DIN 1651 Free cutting steels; technical delivery conditions
- DIN 1810 Hook wrenches
- DIN 4000 Part 2 Tabular layouts of article characteristics for bolts, studs and nuts
- DIN 50942 Phosphating of metals; principles, symbols and test methods
- ISO 4759 Part 1 Tolerances for fasteners; bolts, screws and nuts with thread diameters between 1,6 (inclusive) and 150 mm (inclusive) and product grades A, B and C

Previous editions

08.22, 11.22, 07.39x, 04.49, 02.54x, 11.70.

Amendments

The following amendments have been made in comparison with the November 1970 edition.

- a) The content of the standard has been editorially revised and aligned with the basic standards concerned.
- b) The technical delivery conditions have been amended.
- c) The previous design m as specified in DIN 267 Part 2, April 1968 edition, has been replaced by product grade A as specified in ISO 4759 Part 1.
- d) Limiting dimensions calculated from the permissible tolerances have been included.
- e) Property class 5 as specified in DIN 267 Part 4 has been replaced by the indication of "St = steel".
- f) Sizes M2,3 and M2,6 have been deleted. However, to cater for documents already in existence and spare parts requirements, they can still be ordered in accordance with the November 1970 edition of the present standard.

International Patent Classification

F16 B 37/00