

Countersunk raised head screws (common head style) with
type H or type Z cross recessProduct grade A
(ISO 7047:1994)

English version of DIN EN ISO 7047

DIN

EN ISO 7047

This standard incorporates the English version of ISO 7047.

ICS 21.060.10

Descriptors: Fastener, screw, cross recessed head, raised head screw,
countersunk head screw, dimensions.Supersedes DIN 966 and
DIN ISO 7047, August 1990
editions.Linsen-Senkschrauben (Einheitskopf) mit Kreuzschlitz Form H oder Form Z,
Produktklasse A
(ISO 7047:1994)

European Standard EN ISO 7047:1994 has the status of a DIN Standard.

A comma is used as the decimal marker.

National foreword

This standard has been published in accordance with a decision taken by CEN/TC 185 to adopt, without alteration, international Standard ISO 7047 as a European Standard.

The responsible German body involved in its preparation was the *Normenausschuß Mechanische Verbindungselemente* (Fasteners Standards Committee).

Other relevant ISO Standards on the mechanical properties of tapping screws, tapping screws thread and cross recesses have also been superseded by the corresponding EN ISO Standards.

It should be noted that there are no major changes between the old and the new head dimensions specified in the DIN EN Standards so that interchangeability is not adversely affected. As a rule, interchangeability of products should be checked in such cases where use of automatic feed or assembly systems is being made.

The following table compares the main head dimensions of screws as specified in DIN EN ISO 7047 and DIN 966 and should provide a useful means of deciding whether spare parts can be provided without difficulties.

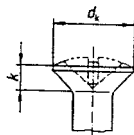

Dimensions in mm

Thread size (d)		M1,6	M2	M2,5	M3	M3,5	M4	M5	M6	M8	M10
$d_{k \max}$	DIN EN ISO 7047	3	3,8	4,7	5,5	7,3	8,4	9,3	11,3	15,8	18,3
	DIN 966	3	3,8	4,7	5,6	6,5	7,5	9,2	11	14,5	18
k_{\max}	DIN EN ISO 7047	1	1,2	1,5	1,65	2,35	2,7	2,7	3,3	4,65	5
	DIN 966	0,96	1,2	1,5	1,65	1,93	2,2	2,5	3	4	5

Continued overleaf.
EN comprises 7 pages.

In order to facilitate the use of countersunk head screws as specified in DIN EN 27721, specifications for countersunks have been given in DIN 66.

The DIN Standards corresponding to the international Standards referred to in clause 2 of the EN are as follows:

ISO Standard	DIN Standard
ISO 225	DIN EN 20 225
ISO 898-1	DIN EN 20 898-1
ISO 4757	DIN EN ISO 4757
ISO 6157-1	DIN EN 26 157-1
ISO 7721	DIN EN 27 721
ISO 8839	DIN EN 28 839

Tabular layout of article characteristics

The DIN 4000-2-1 tabular layout of article characteristics shall apply to the screws covered in this standard.

Amendments

The following amendments have been made to the August 1990 editions of DIN 966 and DIN ISO 7047.

DIN 966 :

- Some of the values of d_k and k have been changed.
- Thread length b has been amended.
- The penetration depths of type H and type Z cross recesses have been amended.
- The range of commercial sizes has been amended.
- Property classes 5.8 and 8.8 are no longer specified.
- The technical delivery conditions have been revised.

DIN ISO 7047:

- For M3 screws, the penetration depths of type Z cross recesses have been amended.
- Guideline values have been specified for the mass.
- The maximum hardness values for fasteners of property class 4.8 are now covered in ISO 898-1:1988.
- With regard to surface discontinuities, reference has been made to ISO 6157-1.
- The standard has been editorially revised.

Previous editions

DIN 966: 1971-12, 1984-12, 1990-08; DIN ISO 7047: 1990-08.

Standards referred to

(and not included in Normative references and Annex ZA)

DIN 66	Countersinks for countersunk head screws with ISO 7721 common head style
DIN 4000-2	Tabular layouts of article characteristics for screws and nuts
DIN EN 20 225	Bolts, screws, studs and nuts; symbols and designations for dimensioning (ISO 225:1983)
DIN EN 20 898-1	Mechanical properties of fasteners; bolts, screws and studs (ISO 898-1:1988)
DIN EN 26 157-1	Fasteners; surface discontinuities; bolts, screws and studs for general requirements (ISO 6157-1:1988)
DIN EN 27 721	Countersunk head screws; head configuration and gauging (ISO 7721:1983)
DIN EN 28 839	Mechanical properties of fasteners; bolts, screws studs and nuts made of non-ferrous metals (ISO 8839:1986)
DIN EN ISO 4757	Cross recesses for screws (ISO 4757:1983)

International Patent Classification

F 16 B 023/00

UDC 621.882.216.5

Descriptors: Fastener, screw, cross recessed head, countersunk head screw, dimensions.

English version

Countersunk raised head screws (common head style)
with type H or type Z cross recess

Product grade A
(ISO 7047:1994)

Vis à métaux à tête fraisée bombée à
empreinte cruciforme de type H ou de
type Z; grade A (ISO 7047:1994)

Linsen-Senkschrauben (Einheitskopf) mit
Kreuzschlitz Form H oder Form Z;
Produktklasse A (ISO 7047:1994)

This European Standard was approved by CEN on 1994-07-26 and is identical to the ISO Standard as referred to.

CEN members are bound to comply with the CEN/CENELEC Internal Regulations which stipulate the conditions for giving this European Standard the status of a national standard without any alteration.

Up-to-date lists and bibliographical references concerning such national standards may be obtained on application to the Central Secretariat or to any CEN member.

This European Standard exists in three official versions (English, French, German). A version in any other language made by translation under the responsibility of a CEN member into its own language and notified to the Central Secretariat has the same status as the official versions.

CEN members are the national standards bodies of Austria, Belgium, Denmark, Finland, France, Germany, Greece, Iceland, Ireland, Italy, Luxembourg, Netherlands, Norway, Portugal, Spain, Sweden, Switzerland and United Kingdom.

CEN

European Committee for Standardization
Comité Européen de Normalisation
Europäisches Komitee für Normung

Central Secretariat: rue de Stassart 36, B-1050 Brussels

Foreword

International Standard

ISO 7047:1994 Countersunk raised head screws (common head style) with type H or type Z cross recess; product grade A which was prepared by ISO/TC 2 'Fasteners' of the International Organization for Standardization, has been adopted by Technical Committee CEN/TC 185 'Threaded and non-threaded mechanical fasteners and accessories' as a European Standard.

This European Standard shall be given the status of a national standard, either by publication of an identical text or by endorsement, and conflicting national standards withdrawn, by January 1995 at the latest.

In accordance with the CEN/CENELEC Internal Regulations, the following countries are bound to implement this European Standard:

Austria, Belgium, Denmark, Finland, France, Germany, Greece, Iceland, Ireland, Italy, Luxembourg, Netherlands, Norway, Portugal, Spain, Sweden, Switzerland and United Kingdom.

Endorsement notice

The text of the International Standard ISO 7047:1994 was approved by CEN as a European Standard without any modification.

NOTE: Normative references to international publications are listed in Annex ZA (normative).

1 Scope

This International Standard specifies the characteristics of countersunk raised head screws of product grade A, with threads from M1,6 to M10 inclusive and with type H or type Z cross recess.

If, in special cases, specifications other than those listed in this International Standard are required, they should be selected from existing International Standards, for example ISO 261, ISO 888, ISO 898-1, ISO 965-2 and ISO 3506.

2 Normative references

The following standards contain provisions which, through reference in this text, constitute provisions of this International Standard. At the time of publication, the editions indicated were valid. All standards are subject to revision, and parties to agreements based on this International Standard are encouraged to investigate the possibility of applying the most recent editions of the standards indicated below. Members of IEC and ISO maintain registers of currently valid International Standards.

ISO 225:1983, *Fasteners — Bolts, screws, studs and nuts — Symbols and designations of dimensions.*

ISO 261:1973, *ISO general purpose metric screw threads — General plan.*

ISO 888:1976, *Bolts, screws and studs — Nominal lengths, and thread lengths for general purpose bolts.*

ISO 898-1:1988, *Mechanical properties of fasteners — Part 1: Bolts, screws and studs.*

ISO 965-2:1980, *ISO general purpose metric screw threads — Tolerances — Part 2: Limits of sizes for general purpose bolt and nut threads — Medium quality.*

ISO 3269:1988, *Fasteners — Acceptance inspection.*

ISO 3506:1979, *Corrosion-resistant stainless steel fasteners — Specifications.*

ISO 4042:1989, *Threaded components — Electroplated coatings.*

ISO 4757:1983, *Cross recesses for screws.*

ISO 4759-1:1978, *Tolerances for fasteners — Part 1: Bolts, screws and nuts with thread diameters between 1,6 (inclusive) and 150 mm (inclusive) and product grades A, B and C.*

ISO 6157-1:1988, *Fasteners — Surface discontinuities — Part 1: Bolts, screws and studs for general requirements.*

ISO 7721:1983, *Countersunk head screws — Head configuration and gauging.*

ISO 8839:1986, *Mechanical properties of fasteners — Bolts, screws, studs and nuts made of non-ferrous metals.*

ISO 8992:1986, *Fasteners — General requirements for bolts, screws, studs and nuts.*

3 Dimensions

See figure 1 and table 1.

The shank diameter is approximately equal to the pitch diameter or equal to the major thread diameter permissible.

NOTE 1 Symbols and designations of dimensions are specified in ISO 225.

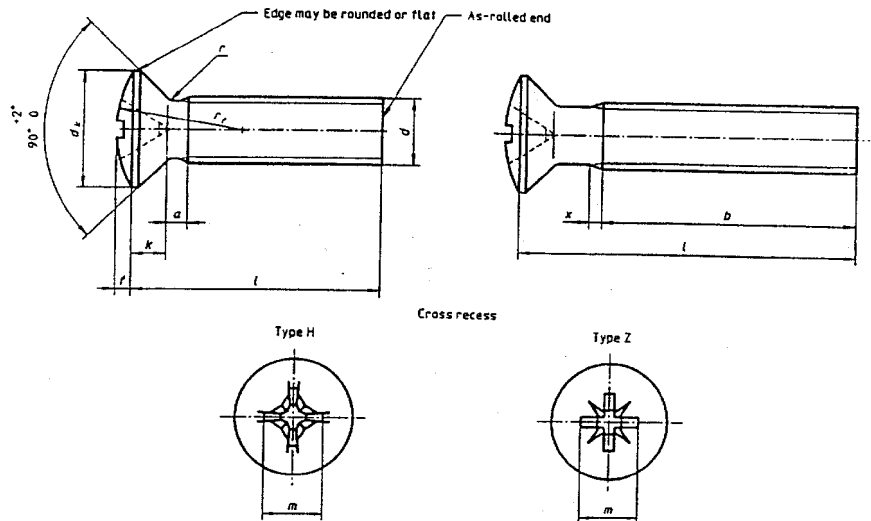

Figure 1

Table 1

Dimensions in millimetres

Thread (d)		M1,6	M2	M2,5	M3	(M3,5) ¹⁾	M4	M5	M6	M8	M10		
P_{21}		0,35	0,4	0,45	0,5	0,6	0,7	0,8	1	1,25	1,5		
a	max.	0,7	0,8	0,9	1	1,2	1,4	1,6	2	2,5	3		
b	min.	25	25	25	25	38	38	38	38	38	38		
d_1^{21}	theoretical	max.	3,6	4,4	5,5	6,3	8,2	9,4	10,4	12,6	17,3		
	actual	nom. = max.	3,0	3,8	4,7	5,5	7,30	8,40	9,30	11,30	15,80		
		min.	2,7	3,5	4,4	5,2	6,94	8,04	8,94	10,87	15,37		
f	=	0,4	0,5	0,6	0,7	0,8	1	1,2	1,4	2	2,3		
$k^{3)}$	nom. = max.	1	1,2	1,5	1,65	2,35	2,7	2,7	3,3	4,65	5		
r	max.	0,4	0,5	0,6	0,8	0,9	1	1,3	1,5	2	2,5		
r_f	=	3	4	5	6	8,5	9,5	9,5	12	16,5	19,5		
x	max.	0,9	1	1,1	1,25	1,5	1,75	2	2,5	3,2	3,8		
Cross recess	Recess	No.	0			1			2			3	
		m	ref.	1,9	2	3	3,4	4,8	5,2	5,4	7,3	9,6	10,4
	Type H	Penetration	max.	1,2	1,5	1,85	2,2	2,75	3,2	3,4	4,0	5,25	6,0
			min.	0,9	1,2	1,50	1,8	2,25	2,7	2,9	3,5	4,75	5,5
	Type Z	Penetration	max.	1,20	1,40	1,75	2,08	2,70	3,10	3,35	3,85	5,20	6,05
			min.	0,95	1,15	1,50	1,83	2,25	2,65	2,90	3,40	4,75	5,60
	Approximate mass, in kilograms per 1 000 pieces ($\rho = 7,85 \text{ kg/dm}^3$) (for information only)												
	nom.	$f^{(1),4)}$ min. max.											
	3	2,8	3,2	0,067	0,119	0,212							
	4	3,76	4,24	0,078	0,138	0,242	0,351						
5	4,76	5,24	0,09	0,156	0,272	0,395	0,669	0,89					
6	5,76	6,24	0,102	0,175	0,302	0,439	0,729	1,07	1,49				
8	7,71	8,29	0,125	0,212	0,362	0,527	0,849	1,23	1,73	2,79			
10	9,71	10,29	0,145	0,249	0,422	0,615	0,969	1,39	1,97	3,14	6,89		
12	11,85	12,35	0,165	0,287	0,482	0,703	1,09	1,54	2,21	3,49	7,53		
(14)	13,65	14,35	0,185	0,325	0,543	0,791	1,21	1,7	2,45	3,84	8,17		
16	15,85	16,35	0,205	0,362	0,603	0,879	1,33	1,85	2,69	4,19	8,81		
20	19,58	20,42		0,436	0,723	1,06	1,57	2,17	3,17	4,89	10,1		
25	24,58	25,42			0,874	1,28	1,87	2,56	3,77	5,77	11,7		
30	29,58	30,42				1,5	2,17	2,95	4,37	6,64	13,3		
35	34,5	35,5					2,47	3,34	4,97	7,52	14,9		
40	39,5	40,5						3,73	5,67	9,39	16,5		
45	44,5	45,5							6,15	9,27	18,1		
50	49,5	50,5								10,1	19,7		
(60)	54,05	55,05							5,76		30,7		
80	69,05	80,05								11	21,3		
										11,9	22,9		
											35,7		

NOTE — Commercial lengths are those between the stepped, continuous, bold lines.

1) Sizes in parentheses should be avoided if possible

2) P = pitch of the thread

3) See ISO 7721.

4) Screws with nominal lengths above the bold dotted line are threaded up to the head, $b = l - (l \pm e)$

4 Specifications and reference International Standards

See table 2.

Table 2

Material		Steel	Stainless steel	Non-ferrous metal
General requirements	International Standard	ISO 8992		
	Tolerance	6g		
Thread	International Standards	ISO 261, ISO 965-2		
	Property class	4.8	A2-50, A2-70	...
Mechanical properties	International Standards	ISO 898-1	ISO 3506	ISO 8839
	Product grade	A		
Tolerances	International Standard	ISO 4759-1		
	International Standard	ISO 4757		
Cross recesses	International Standard	ISO 4757		
	Finish	Plain Requirements for electroplating are covered in ISO 4042. If different electroplating requirements are desired or if requirements are needed for other finishes, they shall be agreed between customer and supplier. Limits for surface discontinuities are covered in ISO 6157-1.		
Acceptability	International Standard	Acceptance procedure is covered in ISO 3269.		

5 Designation

Example of designation: A cross-recessed countersunk raised head screw with thread M5, nominal length $l = 20$ mm, property class 4.8 and cross recess type Z is designated as follows:

Countersunk raised head screw ISO 7047 - M5 x 20 - 4.8 - Z

Annex ZA (normative)**Normative references to international publications
with their relevant European publications**

This European Standard incorporates by dated or undated reference, provisions from other publications. These normative references are cited at the appropriate places in the text and the publications are listed hereafter. For dated references, subsequent amendments to or revisions of any of these publications apply to this European Standard only when incorporated in it by amendment or revision. For undated references the latest edition of the publication referred to applies (including amendments).

<u>Publication</u>	<u>Year</u>	<u>Title</u>	<u>EN/HD</u>	<u>Year</u>
ISO 225	1983	Fasteners - Bolts, screws, studs-Symbols and designation of dimensions	EN 20225	1991
ISO 898-1	1988	Mechanical properties of fasteners - Part 1: Bolts, screws and studs	EN 20898-1	1991
ISO 6157-1	1988	Fasteners - Surface discontinuities - Part 1: Bolts, screws and studs for general requirements	EN 26157-1	1991
ISO 7721	1983	Countersunk head screws - Head configuration and gauging	EN 27721	1991
ISO 8839	1986	Mechanical properties of fasteners - Bolts, screws studs and nuts made of non-ferrous metals	EN 28839	1991