

UDC 621.882.3-034.14:620.17

February 1994

	<p align="center">Mechanical properties of fasteners Nuts with coarse pitch thread and specified proof load values (ISO 898-2: 1992) English version of DIN EN 20898 Part 2</p>	<p align="center">DIN EN 20898 Part 2</p>														
<p align="center">This standard incorporates the English version of ISO 898-2.</p> <p>Mechanische Eigenschaften von Verbindungselementen; Muttern mit festgelegten Prüfkraften, Regelgewinde (ISO 898-2: 1992)</p> <p align="right">Supersedes DIN ISO 898 Part 2, March 1981 edition, and DIN 267 Part 4, August 1983 edition.</p> <p>European Standard EN 20898-2: 1993 has the status of a DIN Standard.</p> <p><i>A comma is used as the decimal marker.</i></p> <p>National foreword</p> <p>This standard has been published in accordance with a decision taken by CEN/TC 185 to adopt, without alteration, International Standard ISO 898-2 as a European Standard.</p> <p>The responsible German body involved in the preparation of this standard was the <i>Normenausschuß Mechanische Verbindungselemente</i> (Fasteners Standards Committee).</p> <p>This standard shall be applicable to all products complying with DIN EN Standards and DIN ISO Standards in which reference is made to ISO 898-2 and with DIN Standards in which reference is made to DIN ISO 898 Part 2.</p> <p>The DIN Standards corresponding to the ISO Standards in clause 2 of the EN are as follows:</p> <table border="0"> <tr> <td>ISO Standard</td> <td>DIN Standard</td> </tr> <tr> <td>ISO 272</td> <td>DIN ISO 272</td> </tr> <tr> <td>ISO 3506</td> <td>DIN ISO 3506</td> </tr> <tr> <td>ISO 6157-2</td> <td>DIN EN 493</td> </tr> </table> <p>Standards referred to (and not included in Normative references)</p> <table border="0"> <tr> <td>DIN ISO 272</td> <td>Fasteners; hexagon products, widths across flats</td> </tr> <tr> <td>DIN ISO 3506</td> <td>Fasteners of stainless steel; technical delivery conditions</td> </tr> <tr> <td>DIN EN 493</td> <td>Fasteners; surface discontinuities; nuts</td> </tr> </table> <p>Previous editions</p> <p>DIN 266: 03.31; DIN 589: 07.31, 01.34; DIN kr 550: 03.36; DIN 267 Parts 1 and 2: 04.37; DIN 267: 06.40, 01.43, 01.54, 12.60; DIN 267 Part 4: 05.68, 10.71, 08.83; DIN 267 Part 8: 04.68, 10.71; DIN ISO 898 Part 2: 03.81.</p> <p align="right">Continued overleaf. EN comprises 19 pages.</p>			ISO Standard	DIN Standard	ISO 272	DIN ISO 272	ISO 3506	DIN ISO 3506	ISO 6157-2	DIN EN 493	DIN ISO 272	Fasteners; hexagon products, widths across flats	DIN ISO 3506	Fasteners of stainless steel; technical delivery conditions	DIN EN 493	Fasteners; surface discontinuities; nuts
ISO Standard	DIN Standard															
ISO 272	DIN ISO 272															
ISO 3506	DIN ISO 3506															
ISO 6157-2	DIN EN 493															
DIN ISO 272	Fasteners; hexagon products, widths across flats															
DIN ISO 3506	Fasteners of stainless steel; technical delivery conditions															
DIN EN 493	Fasteners; surface discontinuities; nuts															

Amendments

The following amendments have been made to DIN ISO 898 Part 2, March 1981 edition, and DIN 267 Part 4, August 1983 edition.

Amendments to DIN ISO 898 Part 2, March 1981 edition:

- a) The DIN number has been changed.
- b) The scope of the standard has been revised.
- c) For property classes 4, 5 and 6, a different maximum phosphorus content has been given.
- d) For property class 8 (type 1), the hardness and proof load values have been amended.
- e) For property class 8 (type 2), hardness and proof load values have been included.
- f) For property class 12 (type 1), proof load values have been included.
- g) For all property classes, marking is mandatory.

Amendments to DIN 267 Part 4, August 1983 edition:

- a) Specifications for nuts with fine pitch thread are no longer included (cf. DIN EN 20898 Part 6).
- b) The property classes have been amended and supplemented.
- c) The chemical composition has been amended.
- d) No reference need be made to the material in the designation where nuts are to be made from free-cutting steel.
- e) Different hardness values have been given.
- f) The stresses under proof load have been amended.
- g) For nuts with nominal heights equal to $0,5 D$, values of stripping strength have been specified.

International Patent Classification

F 16 B 029/00

F 16 B 031/00

F 16 B 033/00

F 16 B 035/00

F 16 B 037/00

EUROPEAN STANDARD
NORME EUROPÉENNE
EUROPÄISCHE NORM

EN 20898-2

December 1993

UDC 621.882.3

Supersedes EN 20898-2:1991.

Descriptors: Fasteners, nuts, coarse thread, specifications, mechanical properties, tests, designation, marking.

English version

Mechanical properties of fasteners
Part 2: Nuts with specified proof load values
Coarse thread
(ISO 898-2:1992)

Caractéristiques mécaniques des éléments de fixation. Partie 2: Ecrous avec charges d'épreuve spécifiées, filetages à pas gros (ISO 898-2:1992)

Mechanische Eigenschaften von Verbindungselementen. Teil 2: Muttern mit festgelegten Prüfkräften; Regalgewinde (ISO 898-2:1992)

This European Standard was approved by CEN on 1993-12-16 and is identical to the ISO Standard as referred to.

CEN members are bound to comply with the CEN/CENELEC Internal Regulations which stipulate the conditions for giving this European Standard the status of a national standard without any alteration.

Up-to-date lists and bibliographical references concerning such national standards may be obtained on application to the Central Secretariat or to any CEN member.

This European Standard exists in three official versions (English, French, German). A version in any other language made by translation under the responsibility of a CEN member into its own language and notified to the Central Secretariat has the same status as the official versions.

CEN members are the national standards bodies of Austria, Belgium, Denmark, Finland, France, Germany, Greece, Iceland, Ireland, Italy, Luxembourg, Netherlands, Norway, Portugal, Spain, Sweden, Switzerland and United Kingdom.

CEN

European Committee for Standardization
Comité Européen de Normalisation
Europäisches Komitee für Normung

Central Secretariat: rue de Stassart 36, B-1050 Brussels

Page 2
EN 20898-2:1993

Foreword

In 1993, CEN/TC 185 'Threaded and unthreaded fasteners and accessories', the Secretariat of which is held by DIN, decided to submit ISO 898-2 to the Unique Acceptance Procedure. The result was positive.

This European Standard supersedes EN 20898-2:1992.

NOTE: The International Standard ISO 6157-2 'Surface discontinuities of nuts' (see subclause 8.3) is not yet available; in the interim, reference shall be made to EN 493 'Fasteners; surface discontinuities; nuts'.

This European Standard shall be given the status of a national standard, either by publication of an identical text or by endorsement, and conflicting national standards withdrawn, by June 1994 at the latest.

In accordance with the CEN/CENELEC Internal Regulations, the following countries are bound to implement this European Standard:

Austria, Belgium, Denmark, Finland, France, Germany, Greece, Iceland, Ireland, Italy, Luxembourg, Netherlands, Norway, Portugal, Spain, Sweden, Switzerland and United Kingdom.

Endorsement notice

The text of the International Standard ISO 898-2:1992 was approved as a European Standard without any modification.

NOTE: Normative references to international publications are listed in annex ZA (normative).

1 Scope

This International Standard specifies the mechanical properties of nuts with specified proof load values when tested at room temperature (see ISO 1). Properties will vary at higher and lower temperature.

It applies to nuts

- with nominal thread diameters up to and including 39 mm;
- of triangular ISO thread and with diameters and pitches according to ISO 68 and ISO 262 (coarse thread);
- with diameter/pitch combinations according to ISO 261 (coarse thread);
- with thread tolerances 6H according to ISO 965-1 and ISO 965-2;
- with specific mechanical requirements;
- with widths across flats as specified in ISO 272 or equivalent;
- with nominal heights greater than or equal to $0,5D^*)$;
- made of carbon steel or low alloy steel.

It does not apply to nuts requiring special properties such as

- locking abilities (see ISO 2320);
- weldability;

- corrosion resistance (see ISO 3508);
- ability to withstand temperatures above + 300 °C or below - 50 °C.

NOTES

- 1 Nuts made from free-cutting steel should not be used above + 250 °C.
- 2 For special products such as nuts for high-strength structural bolting, and overlapped nuts for use with hot-dipped galvanized bolts, see the product standards for appropriate values
- 3 For assemblies with threads having tolerances wider than 6H/6g, there is an increased risk of stripping; see also table 1.
- 4 In the case of thread tolerances other or larger than 6H, a decrease of the stripping strength should be considered (see table 1).

Table 1 — Reduction in thread strength

Thread		Test load, %		
		Thread tolerances		
greater than	less than or equal to	6H	7H	6G
—	M2,5	100	—	95,5
M2,5	M7	100	95,5	97
M7	M16	100	96	97,5
M16	M39	100	98	98,5

*) D is the nominal diameter of the internal thread in accordance with ISO 724.

2 Normative references

The following standards contain provisions which, through reference in this text, constitute provisions of this part of ISO 898. At the time of publication, the editions indicated were valid. All standards are subject to revision, and parties to agreements based on this part of ISO 898 are encouraged to investigate the possibility of applying the most recent editions of the standards indicated below. Members of IEC and ISO maintain registers of currently valid International Standards.

ISO 1:1975, *Standard reference temperature for industrial length measurements.*

ISO 68:1973, *ISO general purpose screw threads — Basic profile.*

ISO 261:1973, *ISO general purpose metric screw threads — General plan.*

ISO 262:1973, *ISO general purpose metric screw threads — Selected sizes for screws, bolts and nuts.*

ISO 272:1982, *Fasteners — Hexagon products — Widths across flats.*

ISO 286-2:1988, *ISO system of limits and fits — Part 2: Tables of standard tolerance grades and limit deviations for holes and shafts.*

ISO 724:1978, *ISO metric screw threads — Basic dimensions.*

ISO 965-1:1980, *ISO general purpose metric screw threads — Tolerances — Part 1: Principles and basic data.*

ISO 965-2:1980, *ISO general purpose metric screw threads — Tolerances — Part 2: Limits of sizes for general purpose bolt and nut threads — Medium quality.*

ISO 4964:1984, *Steel — Hardness conversions.*

ISO 6157-2:—¹⁾, *Fasteners — Surface discontinuities — Part 2: Nuts with threads M5 to M39.*

ISO 6506:1981, *Metallic materials — Hardness test — Brinell test.*

ISO 6507-1:1982, *Metallic materials — Hardness test — Vickers test — Part 1: HV 5 to HV 100.*

ISO 6508:1986, *Metallic materials — Hardness test — Rockwell test (scales A - B - C - D - E - F - G - H - K).*

3 Designation system

3.1 Nuts with nominal heights $> 0,8D$ (effective lengths of thread $> 0,6l$)

Nuts with nominal heights $> 0,8D$ (effective lengths of thread $> 0,6l$) are designated by a number to indicate the maximum appropriate property class of bolts with which they may be mated.

Failure of threaded fasteners due to over-tightening can occur by bolt shank fracture or by stripping of the threads of the nut and/or bolt. Shank fracture is sudden and therefore easily noticed. Stripping is gradual and therefore difficult to detect and this introduces the danger of partly failed fasteners being left in assemblies.

It would therefore be desirable to design threaded connections so that their mode of failure would always be by shank fracture but, unfortunately, because of the many variables which govern stripping strength (nut and bolt material strengths, thread clearances, across-flats dimensions, etc.), nuts would have to be objectionably thick to guarantee this mode in all cases.

A bolt or screw of thread M5 to M39 assembled with a nut of the appropriate property class, in accordance with table 2, is intended to provide an assembly capable of being tightened to the bolt proof load without thread stripping occurring.

However, should tightening beyond bolt proof load take place, the nut design is intended to ensure at least 10 % of the over-tightened assemblies fail through bolt breakage in order to warn the user that the installation practice is not appropriate.

NOTE 5 For more detailed information on the strength of screw thread assemblies, see annex A.

1) To be published

Table 2 — Designation system for nuts with nominal heights $> 0,8D$

Property class of nut	Mating bolts		Nuts	
	Property class	Thread range	Style 1	Style 2
4	3.6; 4.6; 4.8	$> M16$	$> M16$	—
5	3.6; 4.6; 4.8	$< M16$	$< M39$	—
	5.6; 5.8	$< M39$		
6	6.8	$< M39$	$< M39$	—
8	8.8	$< M39$	$< M39$	$> M16$ $< M39$
9	9.8	$< M16$	—	$< M16$
10	10.9	$< M39$	$< M39$	—
12	12.9	$< M39$	$< M16$	$< M39$

NOTE — In general, nuts of a higher property class can replace nuts of a lower property class. This is advisable for a bolt/nut assembly going into a stress higher than the yield stress or the stress under proof load.

3.2 Nuts with nominal heights $> 0,5D$ but $< 0,8D$ (effective heights of thread $> 0,4D$ but $< 0,6D$)

Nuts with nominal heights $> 0,5D$ but $< 0,8D$ (effective height of thread $> 0,4D$ but $< 0,6D$) are designated by a combination of two numbers: the second indicates the nominal stress under proof load on a hardened test mandrel, while the first indicates that the loadability of a bolt-nut assembly is reduced in comparison with the loadability on a hardened test mandrel and also in comparison with a bolt-nut assembly described in 3.1. The effective loading capacity is not only determined by the hardness of the nut and the effective height of thread but also by the tensile strength of the bolt with which the nut is assembled. Table 3 gives the designation system and the stresses under proof load of the nuts. Proof loads are shown in table 6. A guide for minimum expected stripping strengths of the joints when these nuts are assembled with bolts of various property classes is shown in table 7.

Table 3 — Designation system and stresses under proof load for nuts with nominal heights $> 0,5D$ but $< 0,8D$

Property class of nut	Nominal stress under proof load N/mm ²	Actual stress under proof load N/mm ²
04	400	380
05	500	500

4 Materials

Nuts shall be made of steel conforming to the chemical composition limits specified in table 4.

Table 4 — Limits of chemical composition

Property class	Chemical composition limits (check analysis), %				
	C max.	Mn min.	P max.	S max.	
4 ¹⁾ ; 5 ¹⁾ ; 6 ¹⁾	—	0,50	—	0,060	0,150
8; 9	04 ¹⁾	0,58	0,25	0,060	0,150
10 ²⁾	05 ²⁾	0,58	0,30	0,048	0,058
12 ²⁾	—	0,58	0,45	0,048	0,058

1) Nuts of these property classes may be manufactured from free-cutting steel unless otherwise agreed between the purchaser and the manufacturer. In such cases, the following maximum sulfur, phosphorus and lead contents are permissible:
sulfur 0,34 %; phosphorus 0,11 %; lead 0,35 %.

2) Alloying elements may be added, if necessary, to develop the mechanical properties of the nuts.

Nuts of property classes 05, 8 (style 1 above M16), 10 and 12 shall be hardened and tempered.

5 Mechanical properties

When tested by the methods described in clause 8, the nuts shall have the mechanical properties set out in table 5.

Thread	Property class												
	8				10				12				
	Stress under proof load S_p	Vickers hardness HV	Nut	Stress under proof load S_p	Vickers hardness HV	Nut	Stress under proof load S_p	Vickers hardness HV	Nut	Stress under proof load S_p	Vickers hardness HV	Nut	
greater than	min.	state	N/mm ²	min.	state	N/mm ²	min.	state	N/mm ²	min.	state	style	
—	900	170		1 040			1 140			1 150			
M4	915			1 040			1 140			1 150			
M7	940	188	2	1 040	353	QT2	1 140	285	353	272	353	QT2	1
M10	950			1 050			1 170			1 180			
M16	920			1 060			—			1 200			

1) NQT = Not quenched or tempered.

2) QT = Quenched and tempered.

3) The maximum bolt hardness of property classes 8, 10 and 12 will be changed to be 220 HV in the next revision of ISO 898-1:1988. This is the maximum bolt hardness in the thread engagement area whereas only the thread and or the head may have a maximum hardness of 250 HV. Therefore the values of stress under proof load are based on a maximum bolt hardness of 220 HV.

NOTE — Minimum hardness is mandatory only for heat-treated nuts and nuts too large to be proof-load tested. For all other nuts, minimum hardness is not mandatory but is provided for guidance only. For nuts which are not hardened and tempered, and which satisfy the proof-load test, minimum hardness shall not be cause for rejection.

6 Proof load values

Proof load values are given in table 6.

The nominal stress area A_s is calculated as follows:

$$A_s = \frac{\pi}{4} \left(\frac{d_2 + d_3}{2} \right)^2$$

where

$d_2^{(1)}$ is the basic pitch diameter of the external thread;

d_3 is the minor diameter of the external thread;

$$d_3 = d_1 - \frac{H}{6}$$

where

d_1 is the basic minor diameter of the external thread;

H is the height of the fundamental triangle of the thread.

⁽¹⁾ See ISO 724.

Table 6 — Proof load values — Coarse thread

Thread	Thread pitch mm	Nominal stress area of the mandrel A_s mm ²	Property class											
			Proof load ($A_s \times S_p$) N											
			04	06	4	5	6	8	9	10	12	style 1	style 2	
M3	0,5	5,03	1 910	2 500	—	2 600	3 000	4 000	—	4 500	—	5 700	5 800	
M3,5	0,6	6,78	2 580	3 400	—	3 550	4 050	5 400	—	6 100	—	7 700	7 800	
M4	0,7	8,78	3 340	4 400	—	4 550	5 250	7 000	—	7 900	—	10 000	10 100	
M5	0,8	14,2	5 400	7 100	—	8 250	9 500	12 140	—	13 000	—	16 200	16 300	
M6	1	20,1	7 640	10 000	—	11 700	13 500	17 200	—	18 400	—	22 900	23 100	
M7	1	28,9	11 000	14 500	—	16 800	19 400	24 700	—	26 400	—	32 900	33 200	
M8	1,25	36,6	13 900	18 300	—	21 600	24 900	31 800	—	34 400	—	41 700	42 500	
M10	1,5	58	22 000	29 000	—	34 200	39 400	50 500	—	54 500	—	68 100	67 300	
M12	1,75	84,3	32 000	42 200	—	51 400	59 000	74 200	—	80 100	—	98 600	100 300	
M14	2	115	43 700	57 500	—	70 200	80 500	101 200	—	108 300	—	134 800	136 800	
M16	2	157	59 700	78 500	—	95 800	109 900	138 200	—	149 200	—	183 700	186 800	
M18	2,5	192	73 000	96 000	97 900	121 000	138 200	176 600	170 900	176 600	203 500	—	230 400	
M20	2,5	245	93 100	122 500	125 000	154 400	176 400	225 400	218 100	225 400	258 700	—	294 000	
M22	2,5	303	115 100	151 500	154 500	190 900	218 200	278 800	269 700	278 800	321 200	—	363 800	
M24	3	353	134 100	176 500	180 000	222 400	254 200	324 800	314 200	324 800	374 200	—	423 800	
M27	3	459	174 400	229 500	234 100	289 200	330 500	422 300	408 500	422 300	486 500	—	550 800	
M30	3,5	561	213 200	280 500	286 100	353 400	403 900	516 100	498 300	516 100	594 700	—	673 200	
M33	3,5	694	263 700	347 000	353 900	437 200	499 700	638 500	617 700	638 500	735 600	—	832 800	
M36	4	817	310 500	408 500	418 700	514 700	588 200	751 800	727 100	751 800	868 000	—	960 400	
M39	4	976	370 900	488 000	497 800	614 900	702 700	897 900	868 600	897 900	1 035 000	—	1 171 000	

7 Failure loads for nuts with nominal height $> 0,5D$ but $< 0,8D$

The values of failure loads given in table 7 for guidance apply to different bolt classes. Bolt stripping is the expected failure mode for lower strength bolts, while nut stripping can be expected for bolts of higher property classes.

Table 7 — Minimum bolt stress when stripping occurs

Property class of the nut	Proof load stress of the nut N/mm ²	Minimum stress in the core of bolt when stripping occurs N/mm ²			
		for bolts with property class			
		6.8	8.8	10.9	12.9
04	380	260	300	330	350
05	500	290	370	410	480

8 Test methods

8.1 Proof load test

The proof load test shall be used wherever the capacity of available testing equipment permits, and shall be the referee method for sizes $> M5$.

The nut shall be assembled on a hardened and threaded test mandrel as shown in figures 1 and 2. For referee purposes, the axial tensile test is decisive.

The proof load shall be applied against the nut in an axial direction, and shall be held for 15 s. The nut shall resist the load without failure by stripping or rupture, and shall be removable by the fingers after the load is released. If the thread of the mandrel is damaged during the test, the test should be discarded. (It may be necessary to use a manual wrench to start the nut in motion. Such wrenching is permissible provided that it is restricted to one half turn and that the nut is then removable by the fingers.)

The hardness of the test mandrel shall be 45 HRC minimum.

Mandrels used shall be threaded to tolerance class 5h5g except that the tolerance of the major diameter

shall be the last quarter of the 6g range on the minimum material side.

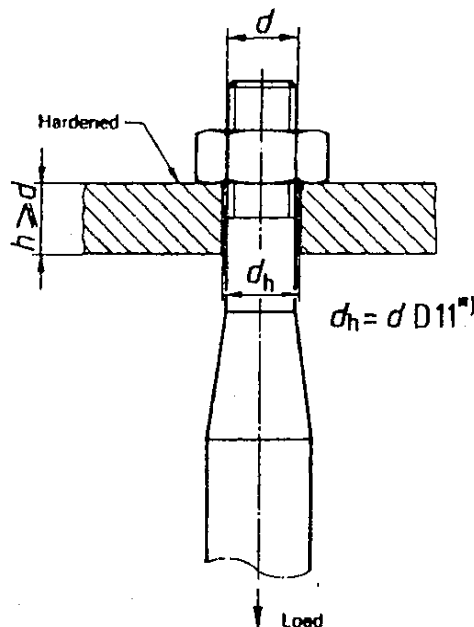

*) D11 is taken from ISO 286-2.

Figure 1 — Axial tensile test

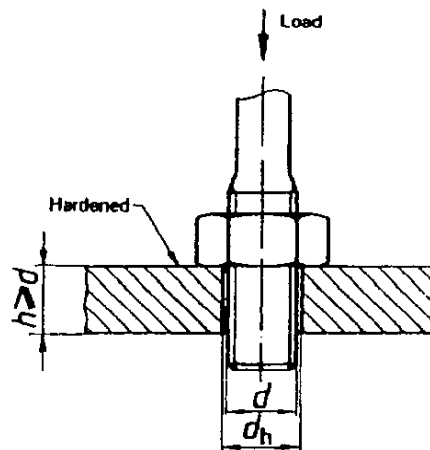

Figure 2 — Axial compressive test

8.2 Hardness test

For routine inspection, hardness tests shall be carried out on one bearing surface of the nut and the hardness shall be taken as the mean of three values spaced 120° apart. In case of dispute, the hardness tests shall be carried out on a longitudinal section through the nut axis and with impressions placed as close as possible to the nominal major diameter of the nut thread.

The Vickers hardness test is the referee test, and where practicable a load of HV 30 shall be applied.

If Brinell and Rockwell hardness tests are applied, the conversion tables in accordance with ISO 4964 shall be used.

The Vickers hardness test shall be carried out in accordance with the requirements of ISO 6507-1.

The Brinell hardness test shall be carried out in accordance with the requirements of ISO 6506.

The Rockwell hardness test shall be carried out in accordance with the requirements of ISO 6508.

8.3 Surface integrity test

For the surface integrity test, see ISO 6157-2.

9 Marking

9.1 Symbols

Marking symbols are shown in tables 8 and 9.

9.2 Identification

Hexagon nuts of threads > M5 and all property classes shall be marked in accordance with the designation system described in clause 3, by indenting on the side or bearing surface, or by embossing on the chamfer. See figures 3 and 4. Embossed marks shall not protrude beyond the bearing surface of the nut.

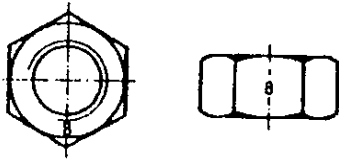

Figure 3 — Examples of marking with designation symbol

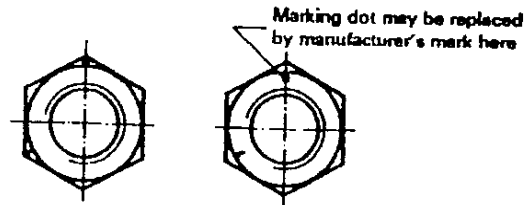

Figure 4 — Examples of marking with code symbol (clock-face system)

Table 8 — Marking symbols for nuts with property classes in accordance with 3.1

Property class	4	5	6	8	9	10	12 ^{*)}
either designation symbol							
Alternative marking or code symbol (clock-face system)							

*) The marking dot cannot be replaced by the manufacturer's mark.

Table 9 — Marking for nuts with property classes in accordance with 3.2

Property class	04	05
Marking		

9.3 Marking of left-hand thread

Nuts with left-hand thread shall be marked as shown in figure 5 on one bearing surface of the nut by indenting.



Figure 5 — Left-hand thread marking

Marking is required for nuts with threads $> M5$.

The alternative marking for left-hand thread shown in figure 6 may also be used.

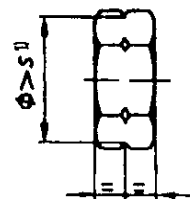

1) r = width across flats.

Figure 6 — Alternative left-hand thread marking

9.4 Alternative marking

Alternative or optional permitted marking as stated in 9.1 to 9.3 is left to the choice of the manufacturer.

9.5 Trade (identification) marking

The trade (identification) marking of the manufacturer is mandatory on all products covered by the obligatory marking requirements for property classes, provided this is possible for technical reasons. Packages, however, shall be marked in all cases.

Annex A (informative)

Loadability of bolted connections

(Explanatory note concerning the specifications of Technical Committee ISO/TC 2
regarding nut strength and nut design.)

Following the introduction of the ISO Recommendation on property classes for bolts and screws (ISO/R 898-1:1968), an ISO Recommendation on property classes for nuts (ISO/R 898-2) was published in 1969. These ISO Recommendations together produced a new system for the property classes of bolts, screws and nuts, and, in conjunction with new marking requirements, provided a clear statement of the loadability of a bolt-nut assembly.

a) In the case of bolts and screws, the symbol indicates:

minimum tensile strength and yield to ultimate stress ratio.

EXAMPLE

Property class 8.8

First figure ("8" in 8.8) = 1/100 of the minimum tensile strength, in newtons per square millimetre.

Second figure ("8" in 8.8) = 10 times the yield stress ratio (0,8).

Multiplication of these two figures ($8 \times 8 = 64$) = 1/10 of the minimum yield stress, in newtons per square millimetre.

b) In the case of nuts:

designation number = 1/100 of the minimum tensile strength, in newtons per square millimetre, of a bolt and screw, which, when mated with the nut, can be loaded up to the minimum yield stress.

EXAMPLE

Bolt or screw 8.8 — nut 8

connection loadable up to minimum yield stress of the bolt or screw.

Following publication of both ISO Recommendations, this system of property classes has been introduced worldwide and has proved to be a success.

In 1973 the Sub-Committee SC 1 of ISO/TC 2 commenced revision of the ISO Recommendations on the basis of experience gathered and also planned to convert both Recommendations into ISO Standards. In 1974, a draft ISO/DIS 898-1 on property classes for bolts and screws was published, incorporating certain modifications and supplements, which, however, did not change the system of the property classes in principle. This draft was then revised once more. A second draft was prepared in 1977 and has since been adopted by a large majority of the member bodies of ISO. While considerable effort was required to develop thoroughly this draft concerning property classes for bolts and screws, it was finally resolved to the satisfaction of the interested countries within Sub-Committee SC 1 of ISO/TC 2 and now is agreed to by ISO. More extensive by far, and touching the substance of the specifications, was the work on a revised version of the ISO Recommendation ISO/R 898-2 and its conversion into an ISO Standard on property classes for nuts.

Experience had shown that, while the concept of property classes in conjunction with a nominal 0,8L nut height is simple and straightforward, certain practical difficulties arise. First, it is sometimes difficult or impossible to achieve specified nut properties with the most economical materials and methods, for example with fine threads and certain sizes of coarse threads. Secondly, compliance with the requirements does not necessarily provide the assurance that the assembly would resist thread stripping during tightening. Previously it was considered adequate if the nut proof load was designed equal to the bolt minimum ultimate strength, however, the advent of yield point tightening methods and improved understanding of the interaction between nut and bolt threads showed the nuts required re-design to provide greater resistance to stripping of both the internal and external threads.

For example, consider that the effective tensile strength of a bolt of class 8.8 may be between 800 N/mm^2 and about 965 N/mm^2 (determined from the maximum hardness) in sizes up to M16. Consequently the yield stress may range between 640 N/mm^2 and 772 N/mm^2 for a yield to ultimate stress ratio of 80 %. With the use of yield point lightening it will be seen that the tightening stress approaches the proof stress. Recent research has, in addition, shown that a nut tested with a hardened mandrel is capable of sustaining a higher load before stripping than when tested with a bolt of the appropriate property class. For example, a property class 8 nut when tested with a mandrel of 45 HRC will be capable of approximately 10 % higher load than when tested with a property class 8.8 bolt of dimensions similar to the mandrel. Therefore, a nut that just meets a proof stress of 800 N/mm^2 with a hardened mandrel might only be expected to sustain a load of approximately 720 N/mm^2 when mated with a property class 8.8 bolt of minimum dimensions. It will be seen that stripping of the threads may occur when tightening to stresses in excess of this, and from the bolt mechanical properties it will be seen that this could be a frequent occurrence with yield point lightening. It might be argued, however, that under torque tension loading the tensile strength of the bolt is reduced by about 15 %, but it should also be realized that the stripping strength of the assembly is also reduced by almost the same amount under torque tension loading. In addition to the introduction of yield point lightening methods, changes in certain ISO standards were under consideration that would also adversely affect this stripping tendency. Upgrading of bolt and screw mechanical properties was proposed as shown in table A.1 (which is an excerpt from ISO 898-1), the purpose of which was to utilize fully the available strength of the commonly used materials for grades 4.8, 5.8, 8.8 (above M16), 10.9 and 12.9.

Another proposed change under consideration at this time was to reduce the width across flats of certain sizes of hexagon products to provide economies through optimized material use. As a result of these and other factors, certain member countries (Canada, Germany, Netherlands, Sweden, UK, USA) of Sub-Committee SC 1 of ISO/TC 2 conducted research and extensive testing of nut-bolt assemblies. Tests included a full variety of product sizes, strength levels and materials. In general, tests were conducted on typical production fasteners utilizing standard materials. Test parts were accurately measured for dimensions and material strength which then allowed appropriate statistical interpretation of the data. Results of the various investigators were evaluated by Canada and found to correlate well. A general series of formulae resulted that could be applied to predict the assembly strength of threaded components with the ISO 68 basic thread profile. These findings were thoroughly

discussed within Sub-Committee SC 1 as well as in the various national committees.

Despite the initial reluctance of the committee to permit changes in existing specifications, the test programme clearly indicated that there was inadequate resistance to assembly stripping, brought about largely by the improved tightening methods and upgrading of mechanical properties. The problem was both one of bolt thread stripping and nut thread stripping, and, as a result, it was concluded that the most viable means of overcoming the problem was by increasing the nominal $0,8D$ nut height where required. It is not the purpose of this annex to provide a detailed description of the tests conducted and the nut design method developed, for which the reader is referred to the following publication which provides a summary of results and the method employed: "*Analysis and Design of Threaded Assemblies*", E.M. Alexander, 1977 SAE Transactions, Paper No. 770420.

The calculation for nuts of property classes 4 to 6 according to the Alexander theory was not based on the maximum bolt hardness 250 HV, as given in ISO 898-1, see table A.1, because this is a hardness which may occur at the bolt end or the head only. Therefore it was agreed to make calculations on the basis of the effective maximum hardnesses within the thread engagement part of the bolt, which are given in table A.2.

Similar graduated hardness values were specified in ISO/R 898-1:1968.

The above work showed that many factors influenced resistance of the stripping of threads, including tolerances, pitch, bell mouching of nut minor diameter, size of countersink in nut, relative strength of nut threads to bolt threads, length of engagement, width across flats of nut, and style (for example hexagon flange), coefficient of friction, number of threads in the grip, etc. Analysis of the various sizes of fasteners on this basis indicated that it was not appropriate to have a fixed nominal nut height, for example $0,8D$ as before, but rather each standard assembly should be designed to give a suitable resistance to stripping. The result of this analysis gives the nut heights shown in table A.3.

It will be seen that there are two styles of nut, style 2 being approximately 10 % higher than style 1. Style 1 height is intended for property classes 4, 5, 6, 8, 10 and 12 (up to M16) in conjunction with appropriate mechanical properties, while style 2 dimensions are intended for use with property classes 8, 9 and 12, also with appropriate mechanical properties. The higher style of nut was primarily developed as an economical cold-formed nut to be used with property class 9.8 bolts and screws and it also provides suitable dimensions for a heat-treatable nut of good ductility for use with property class 12.9 bolts and screws. The intended

applications of the two styles of nuts are detailed in table 5, from which it is seen that this additional style of nut does not mean that dual stocking of part geometry will result.

An overlapping between style 1 and style 2 occurs only in two cases. In the case of style 1, property class 8 allows the employment of nuts, not quenched and tempered (cold-worked low-carbon steel) only up to and including M16; above M16 the nut style 1 has to be quenched and tempered. However, it is possible in this case to use alternatively the thicker, not quenched and tempered, style 2. This is a question of economics in the final analysis. In the case of property class 12, it is not appropriate to use style 1 nuts above size M16. Due to the required proof loads, it would be necessary to raise the hardness of the nut to such an extent that its ductility, which is necessary from the functional point of view, would be impaired. Hence, the thicker style 2 nuts quenched and tempered are necessary in this case. If necessary, it would be possible to restrict the use of these nuts to sizes above M16, so that then no overlapping between style 1 and style 2 would occur in the case of property class 12.

Once nut dimensions were determined based on assembly strength criteria, the proof loads of these nuts with a restricted size hardened mandrel were determined. The result was that stresses under proof load were not constant for each property class of nut but varied with size. Accordingly, table 5 shows revised stresses under proof load and hardness values for nuts. The property classes 04 and 05 (previously 06) for hexagon thin nuts with resultant reduced loadability are also indicated in this table. These nuts incidentally were not designed to provide resistance to stripping and are simply based on a fixed height of $0,6D$.

The stresses under proof load given in table 5 are for the standard tolerance of 6H usually applied to nuts for mechanical fasteners. Where a larger tolerance or allowance is applied, these stresses should be modified by a factor as shown in table 1.

The values of table 5 are only related to nuts with coarse thread. The same applies also to the test loads given in table 1. For nuts with fine pitch thread, see ISO 898-6.

The loads given in table 1 are based on a test mandrel as specified in this part of ISO 898 with a minimum hardness of 45 HRC and thread tolerance of 5h6g (major diameter of 6g in the last quarter).

ISO 898-1 and this part of ISO 898 on mechanical properties, ISO 4014 to ISO 4018 on hexagon bolts and screws, and ISO 4032 to ISO 4036 on hexagonal nuts have been published reflecting the revised mechanical properties, changes in nut heights and changes in width across flats (width across flats of M10, M12, M14 and M22 revised to 16 mm, 18 mm, 21 mm and 34 mm respectively from 17 mm, 19 mm, 22 mm and 32 mm) as recommended by ISO/TC 2.

This part of ISO 898 makes the following statement concerning the property classes for nuts with full loadability:

A bolt or screw of a particular property class assembled with the equivalent property class of nut, in accordance with table 2, is intended to provide an assembly capable of being tightened to achieve a bolt tension equivalent to the bolt proof load or yield load without stripping. Additionally, geometry and mechanical properties of nuts up to M39 and property class 12 of 6H thread tolerances are designed to provide for a high degree of resistance to stripping (at least 10 % bolt breakage of individual lots even under adverse minimum material conditions) when inadvertently overtorqued, in order to warn the user that the installation practice is not appropriate.

Certain users of the referenced standards could not, of necessity, participate in their detailed development and it is hoped that this explanatory note will provide increased understanding of this relatively complicated subject.

Table A.1 — Property classes for bolts and screws

Property class		3.6	4.6	4.8	5.6	5.8	6.8	8.8		9.8	10.9	12.9
								< M16	> M16			
Tensile strength, R_m N/mm ²	nom.	300	400	400	500	500	600	800	800	900	1 000	1 200
	min.	330	400	420	500	520	600	800	830	900	1 040	1 220
Vickers hardness	max.	250 HV	250 HV	250 HV	250 HV	250 HV	250 HV	320 HV	335 HV	360 HV	380 HV	435 HV

Table A.2 — Effective maximum hardness within the thread engagement part of the bolt

Property class	Maximum hardness
3.6	158 HV
4.6; 4.8	180 HV
5.6; 5.8	220 HV
6.8	250 HV

Table A.3 — Heights of hexagon nuts

Thread	Width across flats mm	Nut height					
		Style 1			Style 2		
		min. mm	max. mm	m/D	min. mm	max. mm	m/D
M5	8	4,4	4,7	0,94	4,8	5,1	1,02
M6	10	4,9	5,2	0,87	5,4	5,7	0,95
M7	11	6,14	6,50	0,93	6,84	7,20	1,03
M8	13	6,44	6,80	0,85	7,14	7,50	0,94
M10	16	8,04	8,40	0,84	8,94	9,30	0,93
M12	18	10,37	10,80	0,90	11,57	12,00	1,00
M14	21	12,1	12,8	0,91	13,4	14,1	1,01
M16	24	14,1	14,8	0,92	15,7	16,4	1,02
M18	27	15,1	15,8	0,88	16,9	17,6	0,98
M20	30	16,9	18,0	0,90	19,0	20,3	1,02
M22	34	18,1	19,4	0,88	20,5	21,8	0,93
M24	36	20,2	21,5	0,90	22,6	23,9	1,00
M27	41	22,5	23,8	0,88	25,4	26,7	0,99
M30	46	24,3	25,6	0,85	27,3	28,6	0,95
M33	50	27,4	28,7	0,87	30,9	32,5	0,98
M36	55	29,4	31,0	0,86	33,1	34,7	0,96
M39	60	31,8	33,4	0,86	35,9	37,5	0,96

Annex B (informative)

Bibliography

- [1] ISO 3506:1979, *Corrosion-resistant stainless steel fasteners — Specifications.*
- [2] ISO 4014:1988, *Hexagon head bolts — Product grades A and B.*
- [3] ISO 4015:1979, *Hexagon head bolts — Product grade B — Reduced shank (shank diameter approximately equal to pitch diameter).*
- [4] ISO 4016:1988, *Hexagon head bolts — Product grade C.*
- [5] ISO 4017:1988, *Hexagon head screws — Product grades A and B.*
- [6] ISO 4018:1988, *Hexagon head screws — Product grade C.*
- [7] ISO 4032:1986, *Hexagon nuts, style 1 — Product grades A and B.*
- [8] ISO 4033:1979, *Hexagon nuts, style 2 — Product grades A and B.*
- [9] ISO 4034:1986, *Hexagon nuts — Product grade C.*
- [10] ISO 4035:1986, *Hexagon thin nuts (chamfered) — Product grades A and B.*
- [11] ISO 4036:1979, *Hexagon thin nuts — Product grade B (unchamfered).*

Annex ZA (normative)
Normative references to international publications
with their relevant European publications

This European Standard incorporates by dated or undated reference, provisions from other publications. These normative references are cited at the appropriate places in the text and the publications are listed hereafter. For dated references, subsequent amendments to or revisions of any of these publications apply to this European Standard only when incorporated in it by amendment or revision. For undated references the latest edition of the publication referred to applies (including amendments).

<u>Publication</u>	<u>Year</u>	<u>Title</u>	<u>EN/HD</u>	<u>Year</u>
ISO 1	1975	Standard reference temperature for industrial length measurements	--	--
ISO 68	1973	ISO general purpose screw threads - Basic profile	--	--
ISO 261	1973	ISO general purpose metric screw threads - General plan	--	--
ISO 262	1973	ISO general purpose metric screw threads - Selected sizes for screws, bolts and nuts	--	--
ISO 272	1982	Fasteners - Hexagon products - Widths across flats	--	--
ISO 286-2	1988	ISO system of limits and fits - Part 2: Tables of standard tolerance grades and limit deviations for holes and shafts	EN 20286-2	1993
ISO 724	1978	ISO metric screw threads - Basic dimensions	--	--
ISO 965-1	1980	ISO general purpose metric screw threads - Tolerances - Part 1: Principles and basic data	--	--
ISO 965-2	1980	ISO general purpose metric screw threads - Tolerances - Part 2: Limits of sizes for general purpose bolt and nut threads - Medium quality	--	--
ISO 4964	1984	Steel - Hardness conversions	--	--
ISO 6157-2		Fasteners - Surface discontinuities - Part 2: Nuts with threads M5 to M39	--	--
ISO 6506	1981	Metallic materials - Hardness test - Brinell test	--	--
ISO 6507-1	1982	Metallic materials - Hardness test - Vickers test - Part 1: HV 5 to HV 100	--	--
ISO 6508	1986	Metallic materials - Hardness test - Rockwell test (scales A - B - C - D - E - F - G - H - K)	--	--