

UDC 621.882.2-034.14 : 620.17

April 1992

Mechanical properties of fastenersBolts, screws and studs
(ISO 898-1 : 1988)

English version of DIN EN 20 898 Part 1

DIN**EN 20 898**

Part 1

This standard incorporates the English version of ISO 898-1.

Mechanische Eigenschaften von Verbindungselementen; Schrauben
(ISO 898-1:1988)Supersedes DIN ISO 898 Part 1,
January 1989 edition.

European Standard EN 20 898-1 : 1991 has the status of a DIN Standard.

*A comma is used as the decimal marker.***National foreword**

This standard has been published in accordance with a decision taken by CEN/TC 185 to adopt, without alteration, International Standard ISO 898-1 as a European Standard.

The responsible German body involved in the preparation of this standard was the *Normenausschuß Mechanische Verbindungselemente* (Fasteners Standards Committee).

This standard shall be applicable for all products complying with DIN EN Standards and DIN ISO Standards in which reference is made to ISO 898 Part 1 and with DIN Standards in which reference is made to DIN ISO 898 Part 1.

There follows an amendment, which could not be incorporated in the main body of the standard owing to the obligation to adopt ISO 898-1 : 1988 without alteration:

In clause 2, two ISO Standards are referred to as being at the stage of draft. These have since been published.

The DIN Standards corresponding to the ISO Standards referred to above and in clause 2 of the EN are as follows:

ISO Standard	DIN Standard
ISO 225	DIN EN 20 225
ISO 273	DIN EN 20 273
ISO 6157-1	DIN EN 26 157 Part 1
ISO 6157-3	DIN EN 26 157 Part 3

Standards referred to

See clause 2.

Previous editionsDIN 266: 03.31x; DIN 589: 07.31, 01.34; DIN Kr 550: 03.36; DIN 267 Parts 1 and 2: 04.37;
DIN 267: 06.40, 01.43, 01.54, 12.80; DIN 267 Part 3: 10.67; DIN 267 Part 7: 05.68; DIN ISO 898 Part 1: 04.79, 01.89.**Amendments**

ISO 898-1 having been adopted as a European Standard, the status of the corresponding DIN Standard (DIN ISO 898 Part 1) has been changed accordingly.

International Patent ClassificationF 16 B 31/00
F 16 B 33/00
F 16 B 35/00

EN comprises 20 pages.

EUROPEAN STANDARD
NORME EUROPÉENNE
EUROPÄISCHE NORM

EN 20 898-1

February 1991

UDC 621.882.2-034.14 : 620.17

Descriptors: Fasteners, bolts, screws, studs, specifications, mechanical properties, tests, designation, marking.

English version

Mechanical properties of fasteners

Part 1: Bolts, screws and studs

(ISO 898-1 : 1988)

Caractéristiques mécaniques des éléments de fixation. Partie 1: Boulons, vis et goujons (ISO 898-1 : 1988)

Mechanische Eigenschaften von Verbindungselementen. Teil 1: Schrauben (ISO 898-1 : 1988)

This European Standard was approved by CEN on 1991-02-11 and is identical to the ISO Standard as referred to. CEN members are bound to comply with the CEN/CENELEC Internal Regulations which stipulate the conditions for giving this European Standard the status of a national standard without any alteration.

Up-to-date lists and bibliographical references concerning such national standards may be obtained on application to the Central Secretariat or to any CEN member.

This European Standard exists in three official versions (English, French, German). A version in any other language made by translation under the responsibility of a CEN member into its own language and notified to the Central Secretariat has the same status as the official versions.

CEN members are the national standards bodies of Austria, Belgium, Denmark, Finland, France, Germany, Greece, Iceland, Ireland, Italy, Luxembourg, Netherlands, Norway, Portugal, Spain, Sweden, Switzerland and United Kingdom.

CEN

European Committee for Standardization

Comité Européen de Normalisation

Europäisches Komitee für Normung

Central Secretariat: rue de Stassart 36, B-1050 Brussels

Page 2
EN 20 898-1 : 1991

Foreword

In 1989,

ISO 898-1 : 1988 Mechanical properties of fasteners; bolts, screws and studs
was submitted to the CEN PQ procedure.

Following the positive result of the PQ, CEN/BT agreed to submit ISO 898-1 : 1988, without modifications, to Formal Vote.
In accordance with the CEN/CENELEC Internal Regulations, the following countries are bound to implement this European
Standard:

Austria, Belgium, Denmark, Finland, France, Germany, Greece, Iceland, Ireland, Italy, Luxembourg, Netherlands, Norway,
Portugal, Spain, Sweden, Switzerland and United Kingdom.

Endorsement notice

The text of the International Standard ISO 898-1 : 1988 was approved by CEN as a European Standard without any modification.

NOTE: In table 3, line 5.10, the sign '%' shall be added after the symbol A . In the first line of table 5 and in the head
lines of tables 6 and 8, the symbol ' R_m ' shall be replaced by ' $R_{m \min}$ '.

Contents

	Page		Page
1 Scope and field of application	3	6 Mechanical properties to be determined	7
2 References	3	7 Minimum ultimate tensile loads and proofing loads	9
3 Designation system	3	8 Test methods	11
4 Materials	4	9 Marking	18
5 Mechanical properties	6	Annex: Properties at elevated temperature	20

1 Scope and field of application

This part of ISO 898 specifies the mechanical properties of bolts, screws and studs when tested at room temperature (see ISO 1). Properties will vary at higher and lower temperature.

This part of ISO 898 applies to bolts, screws and studs

- with nominal thread diameter $d < 39$ mm (coarse and fine pitch);
- with triangular ISO thread according to ISO 68;
- with diameter/pitch combinations according to ISO 261 and ISO 262;
- with thread tolerance according to ISO 965-1 and ISO 965-2;
- of any shape;
- made of carbon steel or alloy steel.

It does not apply to set screws and similar threaded fasteners (see ISO 898-5).

It does not specify requirements for such properties as

- weldability;
- corrosion-resistance (see ISO 3506);
- ability to withstand temperatures above +300 °C or below -50 °C.

NOTE — The designation system of this part of ISO 898 may be used for sizes outside the limits laid down in this clause (e.g. $d > 39$ mm), provided that all mechanical requirements of the property classes are met.

2 References

ISO 1, *Standard reference temperature for industrial length measurements.*

ISO 68, *ISO general purpose screw threads — Basic profile.*

ISO 83, *Steel — Charpy impact test (U-notch).*

ISO 225, *Fasteners — Bolts, screws, studs and nuts — Symbols and designations of dimensions.*

ISO 261, *ISO general purpose metric screw threads — General plan.*

ISO 262, *ISO general purpose metric screw threads — Selected sizes for screws, bolts and nuts.*

ISO 273, *Fasteners — Clearance holes for bolts and screws.*

ISO 965-1, *ISO general purpose metric screw threads — Tolerances — Part 1: Principles and basic data.*

ISO 965-2, *ISO general purpose metric screw threads — Tolerances — Part 2: Limits or sizes for general purpose bolt and nut threads — Medium quality.*

ISO 6157-1, *Fasteners — Surface discontinuities — Part 1: Bolts, screws and studs for general requirements.*¹⁾

ISO 6157-3, *Fasteners — Surface discontinuities — Part 3: Bolts, screws and studs for special requirements.*¹⁾

ISO 6506, *Metallic materials — Hardness test — Brinell test.*

ISO 6507-1, *Metallic materials — Hardness test — Vickers test — Part 1: HV 5 to HV 100.*

ISO 6507-2, *Metallic materials — Hardness test — Vickers test — Part 2: HV 0,2 to less than HV 5.*

ISO 6508, *Metallic materials — Hardness test — Rockwell test — Scales A, B, C, D, E, F, G, H, K.*

ISO 6892, *Metallic materials — Tensile testing.*

3 Designation system

The designation system for property classes of bolts, screws and studs is shown in table 1. The abscissae show the nominal tensile strength values, R_m , in newtons per square millimetre, while the ordinates show those of the minimum elongation after fracture, A_{min} , as a percentage.

¹⁾ At present at the stage of draft.

The property class symbol consists of two figures:

- the first indicates 1/100 of the nominal tensile strength in newtons per square millimetre (see R_m in table 3);
- the second figure indicates 10 times the ratio between lower yield stress R_{eL} (or proof stress $R_{p0,2}$) and nominal tensile strength R_m (yield stress ratio).

The multiplication of these two figures will give 1/10 of the yield stress in newtons per square millimetre.

Lower yield stress R_{eL} (or proof stress $R_{p0,2}$) and minimum tensile strength R_m are equal to or greater than the nominal values (see table 3).

4 Materials

Table 2 specifies steels for the different property classes of bolts, screws and studs.

The minimum tempering temperatures listed in table 2 are mandatory for property classes 8.8 to 12.9 in all cases.

The chemical composition limits are mandatory only for those fasteners which are not subject to tensile testing.

Table 1 — System of coordinates

Nominal tensile strength, R_m , N/mm ²	300	400	500	600	700	800	900	1 000	1 200	1 400		
7												
8												
9					6.8				12.9			
10								10.9				
12				6.8			9.8 ¹⁾					
14							8.8					
16			4.8									
18												
20												
22				5.6								
25			4.6									
30	3.6											
Relationship between yield stress and tensile strength												
Second figure of symbol									.6	.8	.9	
$\frac{\text{Lower yield stress } R_{eL} \text{ or proof stress } R_{p0,2}}{\text{Nominal tensile strength } R_m} \times 100$									%	60	80	90

1) Applies only to thread diameter $d < 16$ mm.

NOTE — Although a great number of property classes are specified in this part of ISO 898, this does not mean that all classes are appropriate for all items. Further guidance for application of the specific property classes is given in the relevant product standard. For non-standard items, it is advisable to follow as closely as possible the choice already made for similar standard items.

Table 2 — Steels

Property class	Material and treatment	Chemical composition limits (check analysis) %				Tempering temperature °C min.
		C min.	C max.	P max.	S max.	
3.6 ¹⁾	Carbon steel	—	0,20	0,05	0,06	—
4.6 ¹⁾		—	0,55	0,06	0,06	—
4.8 ¹⁾		—	0,55	0,06	0,06	—
5.6		0,15	0,55	0,06	0,06	—
5.8 ¹⁾		—	0,55	0,05	0,06	
6.8 ¹⁾		—	0,55	0,05	0,06	
8.8 ²⁾	Carbon steel with additives (e.g. Boron or Mn or Cr) quenched and tempered	0,15 ³⁾	0,40	0,035	0,035	425
	or Carbon steel quenched and tempered	0,25	0,55	0,035	0,035	
9.8	Carbon steel with additives (e.g. Boron or Mn or Cr) quenched and tempered	0,15 ³⁾	0,35	0,035	0,035	425
	or Carbon steel quenched and tempered	0,25	0,55	0,035	0,035	
10.9 ⁴⁾	Carbon steel with additives (e.g. Boron or Mn or Cr) quenched and tempered	0,15 ³⁾	0,35	0,035	0,035	340
10.9 ⁵⁾	Carbon steel quenched and tempered	0,25	0,55	0,035	0,035	425
	or Carbon steel with additives (e.g. Boron or Mn or Cr) quenched and tempered	0,20 ³⁾	0,55	0,035	0,035	
	or Alloy steel quenched and tempered ⁷⁾	0,20	0,55	0,035	0,035	
12.9 ^{5), 6)}	Alloy steel quenched and tempered ⁷⁾	0,20	0,50	0,035	0,035	380

- 1) Free cutting steel is allowed for these property classes with the following maximum sulfur, phosphorus and lead contents: sulfur 0,34 %; phosphorus 0,11 %; lead 0,35 %.
- 2) For nominal diameters above 20 mm the steels specified for property class 10.9 may be necessary in order to achieve sufficient hardenability.
- 3) In case of plain carbon boron alloyed steel with a carbon content below 0,25 % (ladle analysis), the minimum manganese content shall be 0,6 % for property class 8.8 and 0,7 % for 9.8 and 10.9.
- 4) Products shall be additionally identified by underlining the symbol of the property class (see clause 9).
- 5) For the materials of these property classes, it is intended that there should be a sufficient hardenability to ensure a structure consisting of approximately 90 % martensite in the core of the threaded sections for the fasteners in the "as-hardened" condition before tempering.
- 6) A metallographically detectable white phosphorous enriched layer is not permitted for property class 12.9 on surfaces subjected to tensile stress.
- 7) Alloy steel shall contain one or more of the alloying elements chromium, nickel, molybdenum or vanadium.

5 Mechanical properties

When tested by the methods described in clause 8, the bolts, screws and studs shall, at room temperature, have the mechanical properties set out in table 3.

Table 3 – Mechanical properties of bolts, screws and studs

Sub-clause No.	Mechanical property	Property class											
		3.6	4.6	4.8	5.6	5.8	6.8	8.8 ¹⁾ <small>$d < 16$ mm</small>	<small>$d > 21$</small>	9.8 ³⁾	10.9	12.9	
5.1 and 5.2	Tensile strength, R_m ^{4), 5)} , N/mm ²	nom.	300	400		500		600	800	800	900	1 000	1 200
		min.	330	400	420	500	520	600	800	830	900	1 040	1 220
5.3	Vickers hardness, HV, $F > 98$ N	min.	95	120	130	155	160	190	250	255	290	320	385
		max.	250						320	335	360	380	435
5.4	Brinell hardness, HB, $F = 30 D^2$	min.	90	114	124	147	152	181	238	242	276	304	366
		max.	238						304	318	342	361	414
5.5	Rockwell hardness, HR	min.	HRB	52	67	71	79	82	89	—	—	—	—
			HRC	—	—	—	—	—	—	22	23	28	32
		max.	HRB	99,5						—	—	—	—
			HRC	—						32	34	37	39
5.6	Surface hardness, HV 0,3	max.	—						6)				
5.7	Lower yield stress, R_{pL} ⁷⁾ , N/mm ²	nom.	180	240	320	300	400	480	—	—	—	—	—
		min.	190	240	340	300	420	480	—	—	—	—	—
5.8	Proof stress, $R_{p0,2}$, N/mm ²	nom.	—						640	640	720	900	1 080
		min.	—						640	660	720	940	1 100
5.9	Stress under proofing load, S_p <small>S_p/R_{pL} or $S_p/R_{p0,2}$</small> N/mm ²		0,94	0,94	0,91	0,93	0,90	0,92	0,91	0,91	0,90	0,88	0,88
			180	225	310	280	380	440	580	600	650	830	970
5.10	Elongation after fracture, A	min.	25	22	14	20	10	8	12	12	10	9	8
5.11	Strength under wedge loading ⁵⁾	The values for full size bolts and screws (not studs) shall not be smaller than the minimum values for tensile strength shown in 5.2											
5.12	Impact strength, J	min.	—		25	—		30	30	25	20	15	
5.13	Head soundness	no fracture											
5.14	Minimum height of non-decarburized thread zone, E	—						$\frac{1}{2} H_1$		$\frac{2}{3} H_1$	$\frac{3}{4} H_1$		
	Maximum depth of complete decarburization, G	mm	—						0,015				

1) For bolts of property class 8.8 in diameters $d < 16$ mm, there is an increased risk of nut stripping in the case of inadvertent over-tightening inducing a load in excess of proofing load. Reference to ISO 898-2 is recommended.

2) For structural bolting the limit is 12 mm.

3) Applies only to nominal thread diameters $d < 16$ mm.

4) Minimum tensile properties apply to products of nominal length $l > 2,5d$. Minimum hardness applies to products of length $l < 2,5d$ and other products which cannot be tensile-tested (e.g. due to head configuration).

5) For testing of full-size bolts, screws and studs, the loads given in tables 6 to 9 shall be applied.

6) Surface hardness shall not be more than 30 Vickers points above the measured core hardness on the product when readings of both surface and core are carried out at HV 0,3. For property class 10.9, any increase in hardness at the surface which indicates that the surface hardness exceeds 390 HV is not acceptable.

7) In cases where the lower yield stress R_{pL} cannot be determined, it is permissible to measure the proof stress $R_{p0,2}$.

6 Mechanical properties to be determined

Two test programmes, A and B, for mechanical properties of bolts, screws and studs, using the methods described in clause 8, are set out in table 5.

The application of programme B is always desirable, but is mandatory for products with breaking loads less than 500 kN.

Programme A is suitable for machined test pieces and for bolts with a shank area less than the stress area.

Table 4 — Key to test programmes (see table 5)

Size	Bolts and screws with thread diameter $d < 4$ mm or length $l < 2,5d$ ¹⁾	Bolts and screws with thread diameter $d > 4$ mm and length $l > 2,5d$
Test decisive for acceptance	○	●

1) Also bolts and screws with special head or shank configurations which are weaker than the threaded section.

Table 5 — Test programmes A and B for acceptance purposes
(These procedures apply to mechanical but not chemical properties.)

Test group	Property		Test programme A				Test programme B			
			Test method		Property class		Test method		Property class	
					3.6, 4.6, 5.6	8.8, 9.8, 10.9, 12.9			3.6, 4.6, 5.8, 6.8	8.8, 9.8, 10.9, 12.9
I	5.1 and 5.2	Minimum tensile strength, R_m	8.1	Tensile test	●	●	8.2	Tensile test ¹⁾	●	●
	5.3	Minimum hardness ²⁾	8.3	Hardness test ³⁾	○	○	8.3	Hardness test ³⁾	○	○
	5.4 and 5.5	Maximum hardness			●	●			●	●
	5.6	Maximum surface hardness			○	○			○	○
II	5.7	Minimum lower yield stress, R_{eL}	8.1	Tensile test	●					
	5.8	Proof stress, $R_{p0.2}$	8.1	Tensile test		●				
	5.9	Stress under proofing load, S_p					8.4	Proofing load test	●	●
III	5.10	Minimum elongation after fracture, A_{min}	8.1	Tensile test	●	●				
	5.11	Strength under wedge loading ⁴⁾					8.5	Wedge loading test ¹⁾	●	●
IV	5.12	Minimum impact strength	8.6	Impact test ⁵⁾	● ⁶⁾	●	8.6			
	5.13	Head soundness ⁷⁾					8.7	Head soundness test	○	○
V	5.14	Maximum decarburized zone	8.8	Decarburization test		●	8.8	Decarburization test		●
	5.15	Minimum tempering temperature	8.9	Retempering test		●	8.9	Retempering test		●
	5.16	Surface integrity	8.10	Surface integrity test	●	●	8.10	Surface integrity test	●	●

- 1) If the wedge loading test is satisfactory, the axial tensile test is not required.
- 2) Minimum hardness applies only to products of nominal length $l < 2,5d$ and other products which cannot be tensile-tested (e.g. due to head configuration).
- 3) Hardness may be Vickers, Brinell or Rockwell. In case of doubt, the Vickers hardness test is decisive for acceptance.
- 4) Special head bolts and screws with configurations which are weaker than the threaded section are excluded from wedge tensile testing requirements.
- 5) Only for bolts, screws and studs with thread diameters $d > 16$ mm and only if required by the purchaser.
- 6) Only property class 5.6.
- 7) Only for bolts and screws with thread diameters $d < 16$ mm and lengths too short to permit wedge load testing.

7 Minimum ultimate tensile loads and proofing loads

See tables 6, 7, 8 and 9

Table 6 – Minimum ultimate tensile loads – ISO metric coarse pitch thread

Thread ¹⁾	Nominal stress area $A_{s,nom}$ mm ²	Property class									
		3.6	4.6	4.8	5.6	5.8	6.8	8.8	9.8	10.9	12.9
Minimum ultimate tensile load ($A_s \times R_m$), N											
M3	5,03	1 660	2 010	2 110	2 510	2 620	3 020	4 020	4 530	5 230	6 140
M3,5	6,78	2 240	2 710	2 850	3 390	3 530	4 070	5 420	6 100	7 050	8 270
M4	8,78	2 900	3 510	3 690	4 390	4 570	5 270	7 020	7 900	9 130	10 700
M5	14,2	4 690	5 680	5 960	7 100	7 380	8 520	11 350	12 800	14 800	17 300
M6	20,1	6 630	8 040	8 440	10 000	10 400	12 100	16 100	18 100	20 900	24 500
M7	28,9	9 540	11 600	12 100	14 400	15 000	17 300	23 100	26 000	30 100	35 300
M8	36,6	12 100	14 600	15 400	18 300	19 000	22 000	29 200	32 900	38 100	44 600
M10	58	19 100	23 200	24 400	29 000	30 200	34 800	46 400	52 200	60 300	70 800
M12	84,3	27 800	33 700	35 400	42 200	43 800	50 600	67 400 ²⁾	75 900	87 700	103 000
M14	115	38 000	46 000	48 300	57 500	59 800	69 000	92 000 ²⁾	104 000	120 000	140 000
M16	157	51 800	62 800	65 900	78 500	81 600	94 000	125 000 ²⁾	141 000	163 000	192 000
M18	192	63 400	76 800	80 600	96 000	99 800	115 000	159 000	—	200 000	234 000
M20	245	80 800	98 000	103 000	122 000	127 000	147 000	203 000	—	255 000	299 000
M22	303	100 000	121 000	127 000	152 000	158 000	182 000	252 000	—	315 000	370 000
M24	353	116 000	141 000	148 000	176 000	184 000	212 000	293 000	—	367 000	431 000
M27	459	152 000	184 000	193 000	230 000	239 000	275 000	381 000	—	477 000	560 000
M30	561	185 000	224 000	236 000	280 000	292 000	337 000	466 000	—	583 000	684 000
M33	694	229 000	278 000	292 000	347 000	361 000	416 000	576 000	—	722 000	847 000
M36	817	270 000	327 000	343 000	408 000	425 000	490 000	678 000	—	850 000	997 000
M39	976	322 000	390 000	410 000	488 000	508 000	586 000	810 000	—	1 020 000	1 200 000

Table 7 – Proofing loads – ISO metric coarse pitch thread

Thread ¹⁾	Nominal stress area $A_{s,nom}$ mm ²	Property class									
		3.6	4.6	4.8	5.6	5.8	6.8	8.8	9.8	10.9	12.9
Proofing load ($A_s \times S_p$), N											
M3	5,03	910	1 130	1 560	1 410	1 910	2 210	2 920	3 270	4 180	4 880
M3,5	6,78	1 220	1 530	2 100	1 900	2 580	2 980	3 940	4 410	5 630	6 580
M4	8,78	1 580	1 980	2 720	2 460	3 340	3 860	5 100	5 710	7 290	8 520
M5	14,2	2 560	3 200	4 400	3 980	5 400	6 250	8 230	9 230	11 800	13 800
M6	20,1	3 620	4 520	6 230	5 630	7 640	8 840	11 600	13 100	16 700	19 500
M7	28,9	5 200	6 500	8 960	8 090	11 000	12 700	16 800	18 800	24 000	28 000
M8	36,6	6 590	8 240	11 400	10 200	13 900	16 100	21 200	23 800	30 400	35 500
M10	58	10 400	13 000	18 000	16 200	22 000	25 500	33 700	37 700	48 100	56 300
M12	84,3	15 200	19 000	26 100	23 600	32 000	37 100	48 900 ³⁾	54 800	70 000	81 800
M14	115	20 700	25 900	35 600	32 200	43 700	50 600	66 700 ³⁾	74 800	95 500	112 000
M16	157	28 300	35 300	48 700	44 000	59 700	69 100	91 000 ³⁾	102 000	130 000	152 000
M18	192	34 600	43 200	59 500	53 800	73 000	84 500	115 000	—	159 000	186 000
M20	245	44 100	55 100	76 000	68 600	93 100	108 000	147 000	—	203 000	238 000
M22	303	54 500	68 200	93 900	84 800	115 000	133 000	182 000	—	252 000	294 000
M24	353	63 500	79 400	109 000	98 800	134 000	155 000	212 000	—	293 000	342 000
M27	459	82 600	103 000	142 000	128 000	174 000	202 000	275 000	—	381 000	445 000
M30	561	101 000	126 000	174 000	157 000	213 000	247 000	337 000	—	466 000	544 000
M33	694	125 000	156 000	215 000	194 000	264 000	305 000	416 000	—	570 000	673 000
M36	817	147 000	184 000	253 000	229 000	310 000	359 000	490 000	—	678 000	792 000
M39	976	176 000	220 000	303 000	273 000	371 000	429 000	586 000	—	810 000	947 000

1) Where no thread pitch is indicated in a thread designation, coarse pitch is specified. This is given in ISO 261 and ISO 262.

2) For structural bolting 70 000, 95 500 and 130 000 N, respectively.

3) For structural bolting 50 700, 68 800 and 94 500 N, respectively.

Table 8 — Minimum ultimate tensile loads — ISO metric fine pitch thread

Thread	Nominal stress area $A_{s,nom}$ mm ²	Property class									
		3.6	4.6	4.8	5.6	5.8	6.8	8.8	9.8	10.9	12.9
Minimum ultimate tensile load ($A_s \times R_m$), N											
M8 × 1	39,2	12 900	15 700	16 500	19 600	20 400	23 500	31 360	35 300	40 800	47 800
M10 × 1	64,5	21 300	25 800	27 100	32 300	33 500	38 700	51 600	58 100	67 100	78 700
M12 × 1,5	88,1	29 100	35 200	37 000	44 100	45 800	52 900	70 500	79 300	91 600	107 500
M14 × 1,5	125	41 200	50 000	52 500	62 500	65 000	75 000	100 000	112 000	130 000	152 000
M16 × 1,5	167	55 100	66 800	70 100	83 500	86 800	100 000	134 000	150 000	174 000	204 000
M18 × 1,5	216	71 300	86 400	90 700	108 000	112 000	130 000	179 000	—	225 000	264 000
M20 × 1,5	272	89 800	109 000	114 000	136 000	141 000	163 000	226 000	—	283 000	332 000
M22 × 1,5	333	110 000	133 000	140 000	166 000	173 000	200 000	276 000	—	346 000	406 000
M24 × 2	384	127 000	154 000	161 000	192 000	200 000	230 000	319 000	—	399 000	469 000
M27 × 2	496	164 000	194 000	208 000	248 000	258 000	298 000	412 000	—	516 000	605 000
M30 × 2	621	205 000	248 000	261 000	310 000	323 000	373 000	515 000	—	646 000	758 000
M33 × 2	761	251 000	304 000	320 000	380 000	396 000	457 000	632 000	—	791 000	928 000
M36 × 3	865	285 000	346 000	363 000	432 000	450 000	519 000	718 000	—	900 000	1 055 000
M39 × 3	1 030	340 000	412 000	433 000	515 000	536 000	618 000	855 000	—	1 070 000	1 260 000

Table 9 — Proofing loads — ISO metric fine pitch thread

Thread	Nominal stress area $A_{s,nom}$ mm ²	Property class									
		3.6	4.6	4.8	5.6	5.8	6.8	8.8	9.8	10.9	12.9
Proofing load ($A_s \times S_p$), N											
M8 × 1	39,2	7 060	8 620	12 200	11 000	14 900	17 200	22 700	25 500	32 500	38 000
M10 × 1	64,5	11 600	14 500	20 000	18 100	24 500	28 400	37 400	41 900	53 500	62 700
M12 × 1,5	88,1	15 900	19 800	27 300	24 700	33 500	38 800	51 100	57 300	73 100	85 500
M14 × 1,5	125	22 500	28 100	38 800	35 000	47 500	55 000	72 500	81 200	104 000	121 000
M16 × 1,5	167	30 100	37 600	51 800	46 800	63 500	73 500	96 900	109 000	139 000	162 000
M18 × 1,5	216	38 900	48 600	67 000	60 500	82 100	95 000	130 000	—	179 000	210 000
M20 × 1,5	272	49 000	61 200	84 300	76 200	103 000	120 000	163 000	—	226 000	264 000
M22 × 1,5	333	59 900	74 900	103 000	93 200	126 000	146 000	200 000	—	276 000	323 000
M24 × 2	384	69 100	86 400	119 000	108 000	146 000	169 000	230 000	—	319 000	372 000
M27 × 2	496	89 300	112 000	154 000	139 000	188 000	218 000	298 000	—	412 000	481 000
M30 × 2	621	112 000	140 000	192 000	174 000	236 000	273 000	373 000	—	515 000	602 000
M33 × 2	761	137 000	171 000	236 000	213 000	289 000	335 000	457 000	—	632 000	738 000
M36 × 3	865	156 000	195 000	268 000	242 000	329 000	381 000	519 000	—	718 000	839 000
M39 × 3	1 030	185 000	232 000	319 000	288 000	391 000	453 000	618 000	—	855 000	999 000

8 Test methods

8.1 Tensile test for machined test pieces

The following properties shall be checked on machined test pieces by tensile tests in accordance with ISO 6892.

- tensile strength, R_m
- lower yield stress, R_{eL} or proof stress of non-proportional elongation 0,2 %, $R_{p0.2}$
- percentage elongation after fracture:

$$A = \frac{L_u - L_0}{L_0} \times 100$$

The test piece shown in figure 1 shall be used for the tensile test.

When machining the test piece, the reduction of the shank diameter of the heat-treated bolts and screws with $d > 16$ mm shall not exceed 25 % of the original diameter (about 44 % of the initial cross-sectional area) of the test piece.

Products in property classes 4.8, 5.8 and 6.8 (cold-forged product) shall be tensile-tested full-size (see 8.2).

8.2 Tensile test for full-size bolts, screws and studs

The tensile test shall be carried out on full-size bolts in conformity with the tensile test on machined test pieces (see 8.1). It is carried out for the purpose of determining the tensile strength. The calculation of the tensile strength, R_m , is based on the stress area A_s :

$$A_s = \frac{\pi}{4} \left(\frac{d_2 + d_3}{2} \right)^2$$

where

d_2^* is the basic pitch diameter of the thread;

d_3 is the minor diameter of the thread

$$d_3 = d_1 - \frac{H}{6}$$

in which

d_1^* is the basic minor diameter,

H is the height of the fundamental triangle of the thread.

For testing of full-size bolts, screws and studs the loads given in tables 6 to 9 shall be applied.

When carrying out the test, a free threaded length equal to one diameter ($1d$) shall be subjected to the tensile load. To meet the requirements of this test, the fracture shall occur in the shank or the thread of the bolt and not at the junction of the head and the shank. The test ring shall be designed accordingly.

The speed of testing, as determined with a free-running cross-head, shall not exceed 25 mm/min. The grips of the testing machine should be self-aligning to avoid side thrust on the specimen.

8.3 Hardness test

For routine inspection, hardness of bolts, screws and studs may be determined on the head, end or shank after removal of any plating or other coating and after suitable preparation of the specimen.

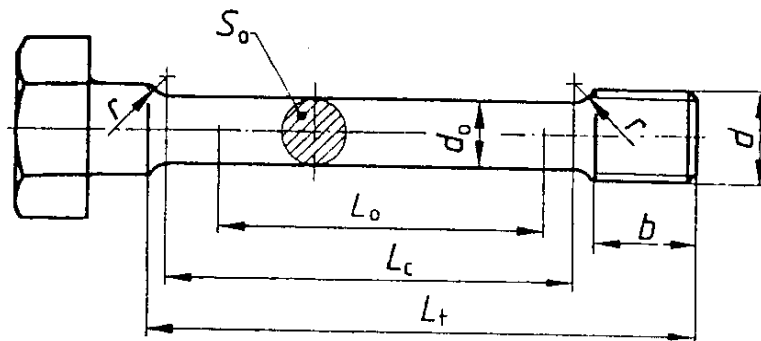

d = nominal thread diameter

d_0 = diameter of test piece ($d_0 < \text{minor diameter of thread}$)

b = length of thread ($b > d$)

$L_0 = 5 d_0$ or $(5,65 \sqrt{S_0})$

L_c = length of straight portion ($L_0 + d_0$)

L_t = total length of test piece ($L_c + 2r + b$)

L_u = length after fracture

S_0 = cross-sectional area

r = fillet radius ($r > 4$ mm)

Figure 1 — Test piece for tensile test

* See ISO 965-1.

For property classes 4.8, 5.8 and 6.8, the hardness shall be determined only on the end of the bolt or screw.

If the maximum hardness is exceeded, a retest shall be conducted at the mid-radius position, one diameter back from the end, at which position the maximum hardness specified shall not be exceeded. In case of doubt, the Vickers hardness test is decisive for acceptance.

Hardness readings for the surface hardness shall be taken on the ends or hexagon flats, which shall be prepared by minimal grinding or polishing to ensure reproducible reading and maintain the original surface of the material. The Vickers test HV 0,3 shall be the referee test for surface hardness testing.

Surface hardness readings taken at HV 0,3 shall be compared with a similar core hardness reading at HV 0,3 in order to make a realistic comparison and determine the relative increase up to 30 Vickers points. An increase of more than 30 Vickers points indicates carburization.

For property classes 8.8 to 12.9 the difference between core hardness and surface hardness is decisive for the judgement of the carburization condition in the surface layer of the bolt, screw or stud.

There may not be a direct relationship between hardness and theoretical tensile strength. Maximum hardness values have been selected for reasons other than theoretical maximum strength considerations (e.g. to avoid embrittlement).

NOTE – Careful differentiation must be made between an increase in hardness caused by carburization and that due to heat-treatment or cold working of the surface.

8.3.1 Vickers hardness test

The Vickers hardness test shall be carried out in accordance with ISO 6507.

8.3.2 Brinell hardness test

The Brinell hardness test shall be carried out in accordance with ISO 6506.

8.3.3 Rockwell hardness test

The Rockwell hardness test shall be carried out in accordance with ISO 6508.

8.4 Proofing load test for full-size bolts

The proofing load test consists of two main operations, as follows:

- a) application of a specified tensile proofing load (see figure 2), and
- b) measurement of permanent extension, if any, caused by the proofing load.

The proofing load, as given in tables 7 and 9, shall be applied axially to the bolt in a normal tensile testing machine. The full proofing load shall be held for 15 s. The length of free thread subject to the load shall be 6 pitches of the thread (6P).

For screws threaded to the head, the length of free thread subjected to the load shall be as close as practical to 6 pitches of the thread.

For measurement of permanent extension, the bolt shall be axially centre-drilled (60° cone) at each end. Before and after the application of the proofing load, the bolt shall be placed in a bench-mounted measuring instrument fitted with spherical anvils. Gloves or tongs shall be used to minimize measurement error.

To meet the requirements of the proofing load test, the length of the bolt, screw or stud after loading shall be the same as before loading within a tolerance of $\pm 12,5 \mu\text{m}$ allowed for measurement error.

The speed of testing, as determined with a free-running cross-head, shall not exceed 3 mm/min. The grips of the testing machine should be self-aligning to avoid side thrust on the specimen.

Some variables, such as straightness and thread alignment (plus measurement error), may result in apparent elongation of the fasteners when the proofing load is initially applied. In such cases, the fasteners may be retested using a 3 % greater load, and may be considered satisfactory if the length after this loading is the same as before this loading (within the $12,5 \mu\text{m}$ tolerance for measurement error).

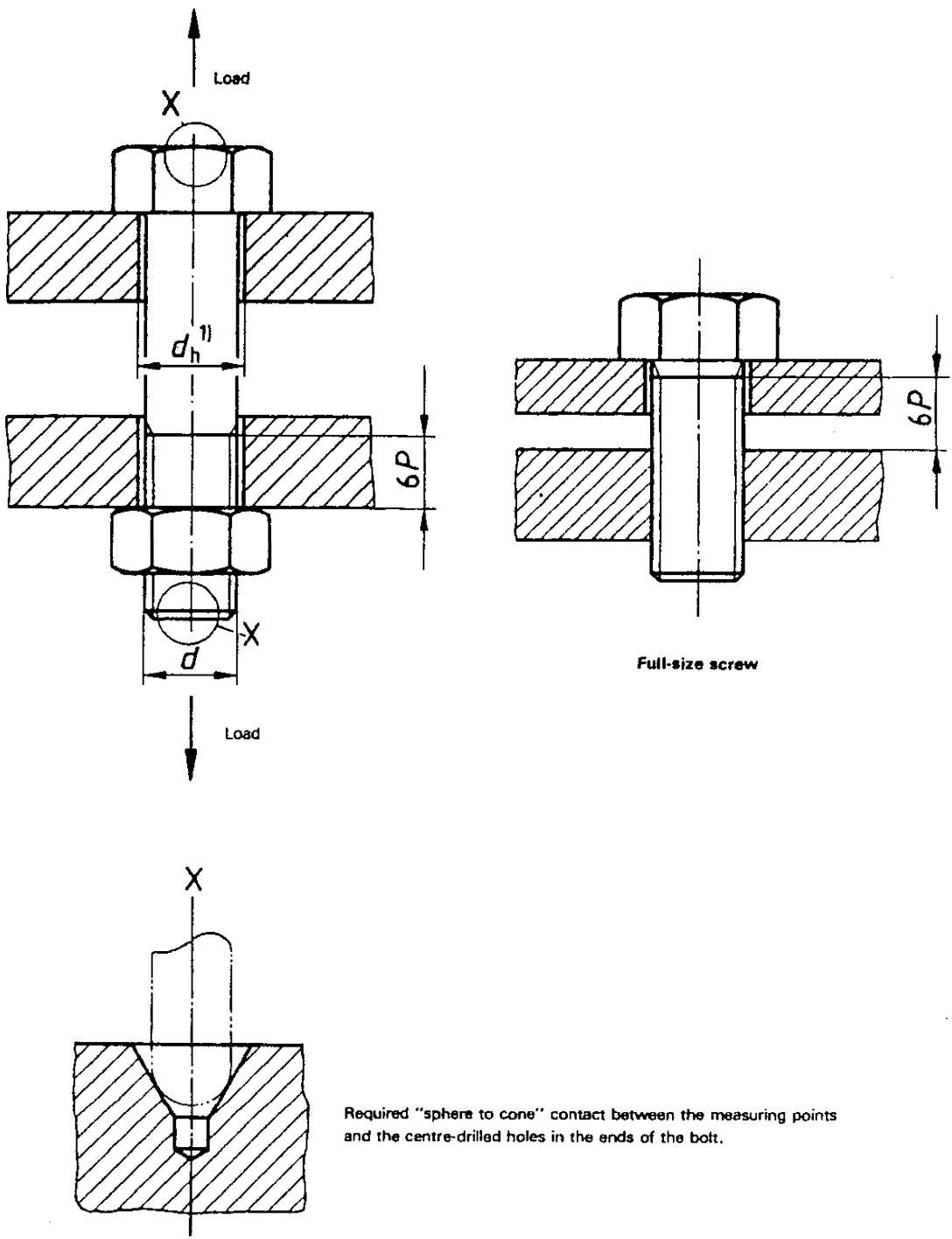

1) d_h according to ISO 273, medium series (see table 10).

Figure 2 — Application of proofing load to full-size bolts

8.5 Test for strength under wedge loading of full-size bolts and screws (not studs)

The test for strength under wedge loading shall be carried out as illustrated in figure 3.

The minimum distance from the thread run-out of the bolt to the contact surface of the nut of the fastening device shall be d . A hardened wedge in accordance with tables 10 and 11 shall be placed under the head of the bolt. A tensile test shall be continued until fracture occurs.

To meet the requirements of this test, the fracture shall occur in the shank or the thread of the bolt, and not between the head and the shank. The bolt shall meet the requirements for minimum tensile strength, either during wedge tensile testing or in a supplementary tensile test without a wedge, according

to the values given for the relevant property class before fracture occurs.

Screws threaded to the head shall pass the requirement of this test if a fracture which causes failure originates in the free length of thread, even if it has extended or spread into the filler area or the head before separation.

For product grade C, a radius r_1 should be used according to the formula

$$r_1 = r_{\text{max.}} + 0,2$$

$$\text{where } r_{\text{max.}} = \frac{d_a \text{ max.} - d_s \text{ min.}}{2}$$

NOTE — Symbols r , d_a and d_s are defined in ISO 225.

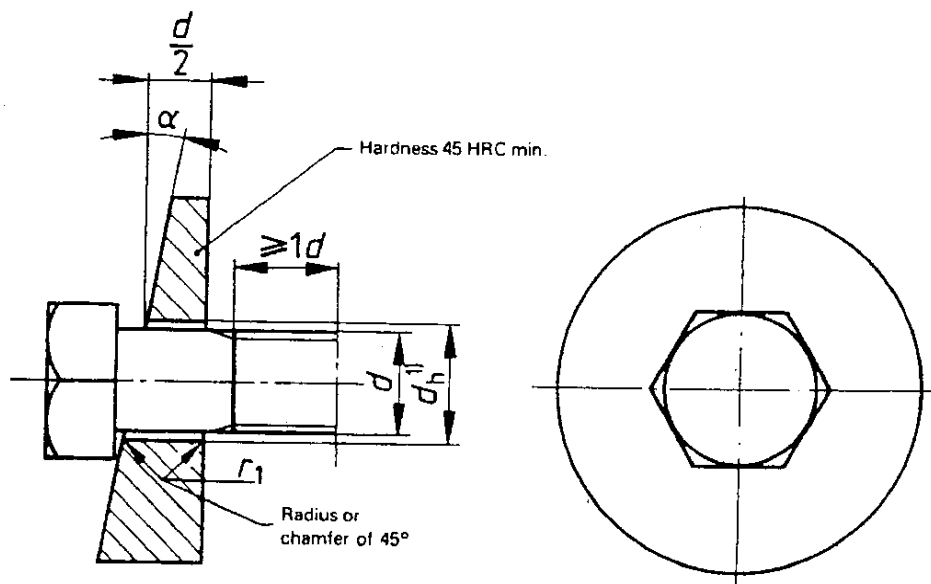

1) d_h according to ISO 273, medium series.

Figure 3 — Wedge loading of full-size bolts

Table 10 — Hole diameters for wedge loading test

Nominal thread diameter, d	3	3,5	4	5	6	7	8	10	12	14
d_h	3,4	3,9	4,5	5,5	6,6	7,6	9	11	13,5	15,5
r_1	0,7	0,7	0,7	0,7	0,7	0,8	0,8	0,8	0,8	1,3

Dimensions in millimetres

Nominal thread diameter, d	15	18	20	22	24	27	30	33	36	39
d_h	17,5	20	22	24	26	30	33	36	39	42
r_1	1,3	1,3	1,3	1,6	1,6	1,6	1,6	1,6	1,6	1,6

Table 11 – Wedge dimensions

Nominal diameter of bolt and screw d mm	Property class for:			
	bolts and screws with plain shank length $l_s > 2d$		bolts and screws threaded to the head or with plain shank length $l_s < 2d$	
	3.6, 4.6, 4.8, 5.6, 5.8, 8.8, 9.8, 10.9	6.8, 12.9	3.6, 4.6, 4.8, 5.6, 5.8, 8.8, 9.8, 10.9	6.8, 12.9
	α $\pm 30'$			
$d < 20$	10°	6°	6°	4°
$20 < d < 39$	6°	4°	4°	4°

For products with head bearing diameters above $1,7d$ which fail the wedge tensile test, the head may be machined to $1,7d$ and re-tested on the wedge angle specified in table 11.

Moreover for products with head bearing diameters above $1,9d$, the 10° wedge angle may be reduced to 6°.

8.6 Impact test for machined test pieces

The impact test shall be carried out in accordance with ISO 83. The test piece shall be taken lengthwise, located as close to the surface of the bolt or screw as possible. The non-notched side of the test piece shall be located near the surface of the bolt. Only bolts of thread diameters $d > 16$ mm can be tested.

8.7 Head soundness test for full size bolts with $d < 16$ mm and with lengths too short to permit wedge load testing

The head soundness test shall be carried out as illustrated in figure 4.

When struck several blows with a hammer, the head of the bolt or screw shall bend to an angle of $90^\circ - \beta$ without showing any sign of cracking at the shank head fillet, when viewed at a magnification of not less than X8 nor more than X10.

Where screws are threaded up to the head, the requirements may be considered met even if a crack should appear in the first thread, provided that the head does not snap off.

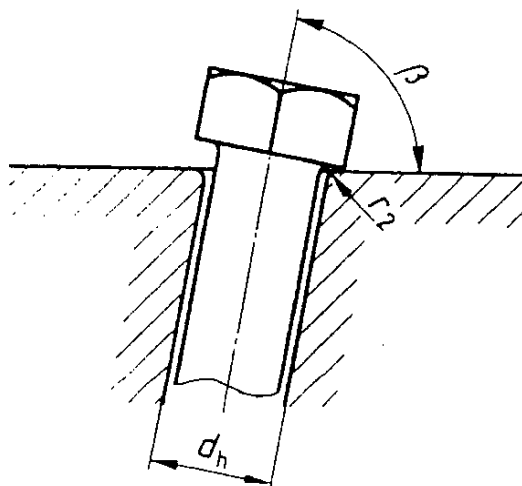

NOTES

- For d_h and r_2 (where $r_2 = r_1$), see table 10.
- The thickness of the test plate should be over $2d$.

Figure 4 – Head soundness test

Table 12 – Values of angle β

Property class	3.6	4.6	5.6	4.8	5.8	6.8	8.8	9.8	10.9	12.9
β	60°					80°				

8.8 Decarburization test

Using the appropriate measuring method (8.8.2.1 or 8.8.2.2 as applicable), the longitudinal section of the thread shall be examined to determine that the height of the zone of base metal (E) and the depth of the zone with complete decarburization (G) are within specified limits (see figure 5).

The maximum value for G and the formulae for the minimum value for E are specified in table 3.

8.8.1 Definitions

8.8.1.1 base metal hardness: Hardness closest to the surface (when traversing from core to outside diameter) just before an increase or decrease occurs denoting carburization or decarburization.

8.8.1.2 decarburization: Generally, loss of carbon at the surface of commercial ferrous materials (steels).

8.8.1.3 partial decarburization: Decarburization with loss of carbon sufficient to cause a lighter shade of tempered martensite and significantly lower hardness than that of the adjacent base metal.

8.8.1.4 complete decarburization: Decarburization with sufficient carbon loss to show only clearly defined ferrite grains under metallographic examination.

8.8.1.5 carbon restoration: A process of restoring surface carbon loss by heat-treating in a furnace atmosphere of properly controlled carbon potential.

8.8.1.6 carburization: A process of increasing surface carbon to a content above that of the base metal.

8.8.2 Measurement methods

8.8.2.1 Microscopic method

This method allows the determination of both E and G .

The specimens to be used are longitudinal sections taken through the thread axis approximately one nominal diameter ($1d$) from the end of the bolt, screw and stud, after all heat-treatment operations have been performed on the product. The specimen shall be mounted for grinding and polishing in a clamp or, preferably, a plastic mount.

After mounting, grind and polish the surface in accordance with good metallographic practice.

Etching in a 3 % nital (concentrated nitric acid in ethanol) solution is usually suitable to show changes in microstructure caused by decarburization.

Unless otherwise agreed between the interested parties, X100 magnification shall be used for examination.

If the microscope is of a type with a ground glass screen, the extent of decarburization can be measured directly with a scale. If an eyepiece is used for measurement, it should be of an appropriate type, containing a cross-hair or a scale.

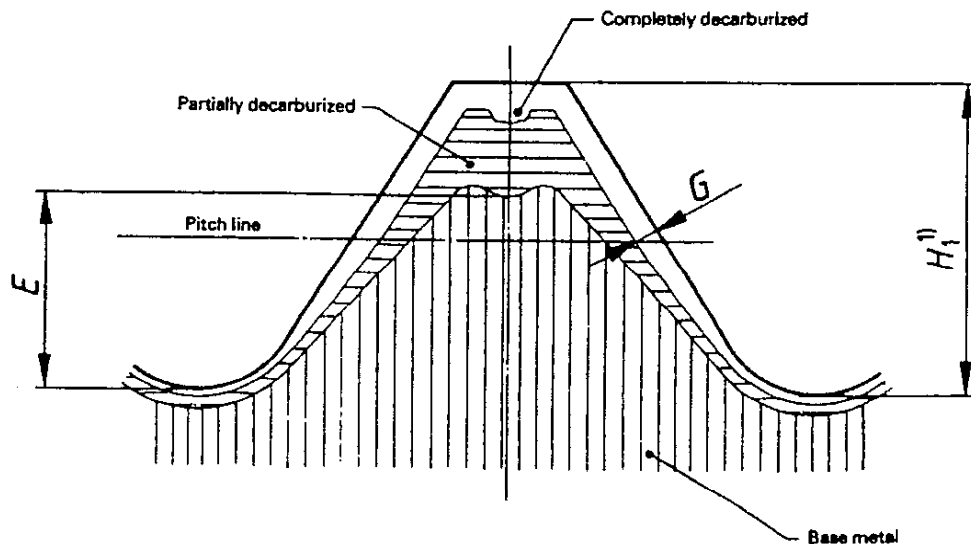

1) H_1^0 = external thread height in the maximum material condition.

Figure 5 – Zones of decarburization

8.8.2.2 Hardness method (Referred method for partial decarburization)

The hardness measurement method is applicable only for threads with pitches, P , of 1,25 mm and larger.

The hardness measurements are made at three points in accordance with figure 6. Formulae for E are given in table 3. The load shall be 300 g.

The hardness determination for point 3 shall be made on the pitch line of the thread adjacent to the thread on which determinations at points 1 and 2 are made.

The Vickers hardness value at point 2 shall be equal to or greater than that at point 1 minus 30 Vickers units. In this case the height of the non-decarburized zone E shall be at least as specified in table 13.

The Vickers hardness value at point 3 shall be equal to or less than that at point 1 plus 30 Vickers units.

Complete decarburization up to the maximum specified in table 3 cannot be detected by the hardness measurement method.

8.9 Retempering test

The mean of three hardness readings on a bolt or screw tested before and after retempering shall not differ by more than 20 Vickers points when retempered and held at a temperature 10 °C less than the specified minimum tempering temperature for 30 min.

8.10 Surface integrity test

For the surface integrity test, see ISO 6157-1 and ISO 6157-3.

The surface integrity test is applied to test programme A test bolts before machining.

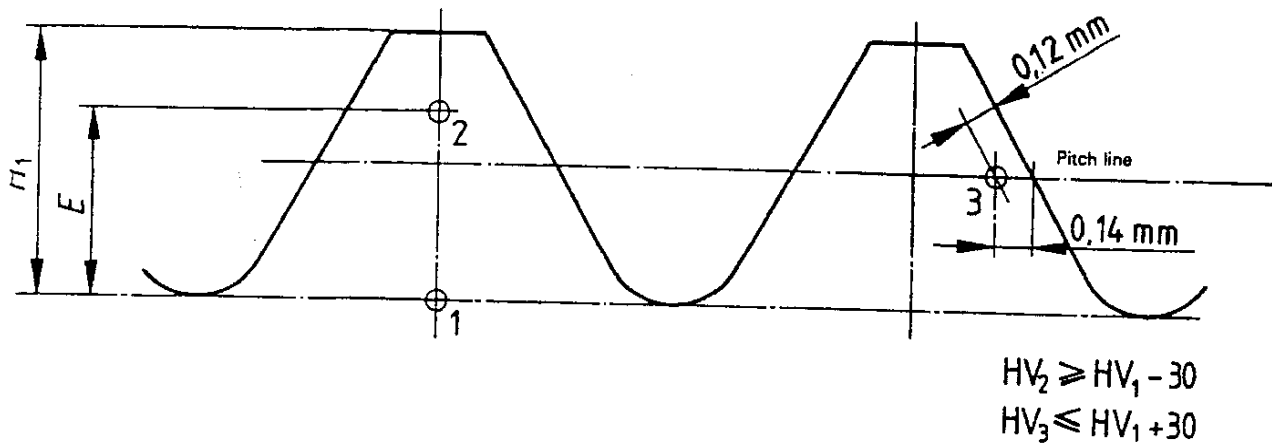

Figure 6 – Hardness measurements for decarburization test

Table 13 – Values for H_1 and E

Pitch of the thread, $P^{1)}$ mm		0,5	0,6	0,7	0,8	1	1,25	1,5	1,75	2	2,5	3	3,5	4	
H_1 mm		0,307	0,368	0,429	0,491	0,613	0,767	0,920	1,074	1,227	1,534	1,840	2,147	2,454	
Property class	8.8, 9.8	E min. mm	0,154	0,184	0,215	0,245	0,307	0,384	0,460	0,537	0,814	0,767	0,920	1,074	1,227
	10.9		0,205	0,245	0,286	0,327	0,409	0,511	0,613	0,716	0,818	1,023	1,227	1,431	1,636
	12.9		0,230	0,276	0,322	0,368	0,460	0,575	0,690	0,808	0,920	1,151	1,380	1,610	1,841

1) For $P < 1$ mm, microscopic method only.

9 Marking

9.1 Symbols

Marking symbols are shown in table 14.

9.2 Identification

9.2.1 Hexagon bolts and screws

Hexagon bolts and screws shall be marked with the designation symbol of the property class described in clause 3.

The marking is obligatory for all property classes, preferably on the top of the head by indenting or embossing or on the side of the head by indenting (see figure 7).

Marking is required for hexagon bolts and screws with nominal diameters $d > 5$ mm where the shape of the product allows it, preferably on the head.

9.2.2 Hexagon socket head cap screws

Hexagon socket head cap screws shall be marked with the designation symbol of the property class described in clause 3.

The marking is obligatory for property classes equal to or higher than 8.8, preferably on the side of the head by indenting or on the top of the head by indenting or embossing (see figure 8).

Marking is required for hexagon socket head cap screws with nominal diameters $d > 5$ mm where the shape of the product allows it, preferably on the head.

The clock-face marking system as given for nuts in ISO 898-2 may be used as an alternative method on small hexagon socket head cap screws.

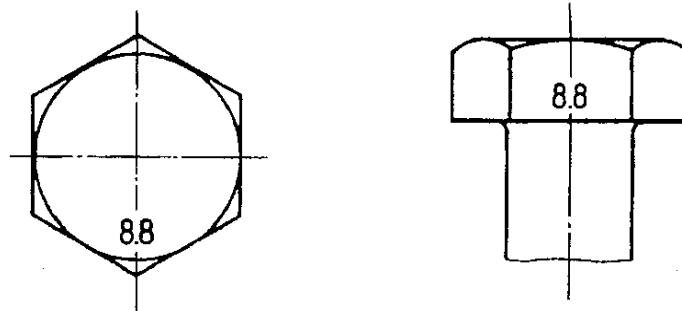

Figure 7 – Examples of marking on hexagon bolts and screws

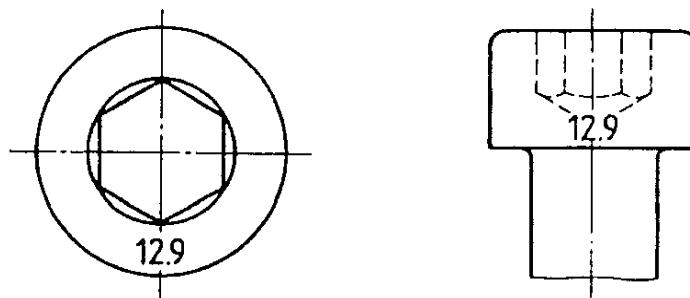

Figure 8 – Examples of marking on hexagon socket head cap screws

Table 14 – Marking symbols

Property class	3.6	4.6	4.8	5.6	5.8	6.8	8.8	9.8	10.9	12.9
Marking symbol ^{1), 2)}	3.6	4.6	4.8	5.6	5.8	6.8	8.8	9.8	10.9	12.9

1) The full-stop in the marking symbol may be omitted

2) When low carbon martensitic steels are used for property class 10.9 (see table 2), the symbol 10.9 shall be underlined 10.9

Table 15 – Identification marks for studs

Property class	8.8	9.8	10.9	12.9
Identification mark	○	+	□	△

9.2.3 Studs

Studs shall be marked with the designation symbol of the property class described in clause 3.

The marking is obligatory for property classes equal to or higher than 8.8, preferably on the extreme end of the threaded portion by indenting (see figure 9). For studs with interference fit, the marking shall be at the nut end.

Marking is required for studs with nominal diameters equal to or greater than 5 mm.

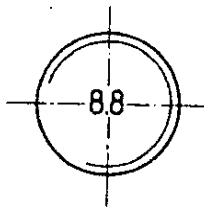

Figure 9 – Marking of stud

The symbols in table 15 are permissible as an alternative identification method.

9.2.4 Other types of bolts and screws

The same marking system as described in 9.2.1 and 9.2.2 shall be used for other types of bolts and screws of property classes 4.6, 5.6 and all classes equal to or higher than 8.8, as described in the appropriate International Standards or, for special components, as agreed between the interested parties.

9.3 Marking of left-hand thread

Bolts and screws with left-hand thread shall be marked with the symbol shown in figure 10, either on the top of the head or the point.

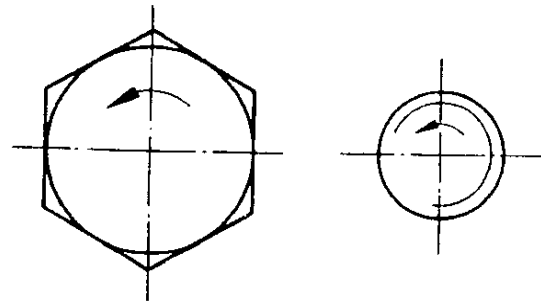
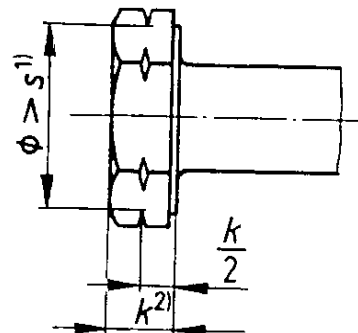

Figure 10 – Left-hand thread marking

Marking is required for bolts and screws with nominal thread diameters $d > 5$ mm.

Alternative marking for left-hand thread may be used for hexagon bolts and screws as shown in figure 11.



- 1) s is the width across flats.
- 2) k is the height of the head.

Figure 11 – Alternative left-hand thread marking

9.4 Alternative marking

Alternative or optional permitted marking as stated in 9.1 to 9.3 should be left to the choice of the manufacturer.

9.5 Trade (identification) marking

The trade (identification) marking of the manufacturer is mandatory on all products which are marked with property classes.

Annex

Properties at elevated temperature

(This annex does not form an integral part of the Standard.)

Table 16 – Properties at elevated temperature

Property class	Temperature, °C				
	+20	+100	+200	+250	+300
	Lower yield stress, R_{eL} , or proof stress, $R_{p0,2}$ N/mm ²				
5.6	300	270	230	215	195
8.8	640	590	540	510	480
10.9	940	875	790	745	705
12.9	1 100	1 020	925	875	825

The data shown in table 16 is for guidance only and is an approximate presentation of the reduction in the mechanical properties which will be experienced when tensile-tested at elevated temperatures. Such data shall not be used as test requirements for bolts, screws and studs.