

# 梯形螺纹 极限尺寸

GB 12359—90

## Limits of sizes for metric trapezoidal screw threads

### 1 主题内容与适用范围

本标准规定了《梯形螺纹》中内、外螺纹选用公差带的极限尺寸。  
本标准适用于GB 5796.1~5796.4—86所规定的梯形螺纹。

### 2 引用标准

- GB 5796.1 梯形螺纹 牙型
- GB 5796.2 梯形螺纹 直径与螺距系列
- GB 5796.3 梯形螺纹 基本尺寸
- GB 5796.4 梯形螺纹 公差

### 3 内螺纹的极限尺寸

3.1 内螺纹公差带位置见图1。



图1 内螺纹公差带

图中： $D_{4min}$ ——内螺纹大径最小尺寸；  
 $D$ ——内螺纹公称直径；  
 $D_2$ ——内螺纹中径基本尺寸；

---

$D_{1max}$ ——内螺纹小径最大尺寸;

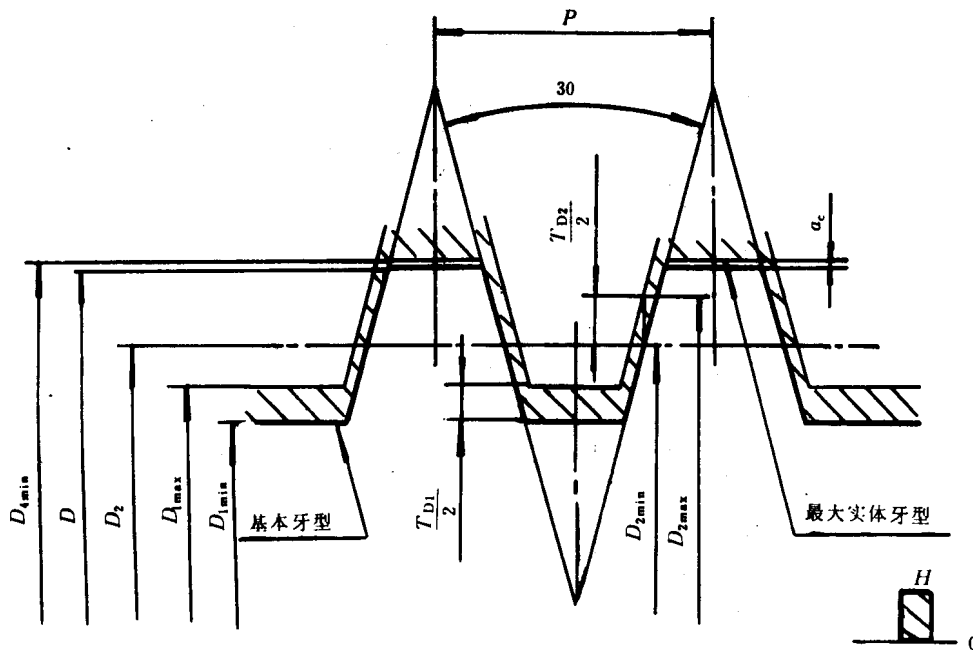
$D_{1min}$ ——内螺纹小径最小尺寸;

$D_{2min}$ ——内螺纹中径最小尺寸;

$D_{2max}$ ——内螺纹中径最大尺寸;

$P$ ——螺距;

$a_c$ ——牙顶间隙。

续表 1

mm

公称直径 $D$	螺距 $P$	大 径 $D_1 = D_{1min}$	中 径			小 径		
			公差带	最小尺寸 $D_{2min}$	最大尺寸 $D_{2max}$	公差带	最小尺寸 $D_{1min}$	最大尺寸 $D_{1max}$
10	2	10.500	7 H	9.000	9.250	4 H	8.000	8.236
			8 H		9.315			
			9 H		9.400			
11	2	11.500	7 H	10.000	10.250	4 H	9.000	9.236
			8 H		10.315			
			9 H		10.400			
	3	11.500	7 H	9.500	9.780	4 H	8.000	8.315
12	2	12.500	7 H	11.000	11.265	4 H	10.000	10.236
			8 H		11.335			
			9 H		11.425			
	3	12.500	7 H	10.500	10.800	4 H	9.000	9.315
14	2	14.500	7 H	13.000	13.265	4 H	12.000	12.236
			8 H		13.335			
			9 H		13.425			
	3	14.500	7 H	12.500	12.800	4 H	11.000	11.315
16	2	16.500	7 H	15.000	15.265	4 H	14.000	14.236
			8 H		15.335			
			9 H		15.425			
	4	16.500	7 H	14.000	14.355	4 H	12.000	12.375
			8 H		14.450			
			9 H		14.560			

续表 1

mm

公称直径 $D$	螺距 $P$	大 径 $D_1 = D_{1\min}$	中 径			小 径		
			公差带	最小尺寸 $D_{2\min}$	最大尺寸 $D_{2\max}$	公差带	最小尺寸 $D_{1\min}$	最大尺寸 $D_{1\max}$
18	2	18.500	7 H 8 H 9 H	17.000	17.265 17.335 17.425	4 H	16.000	16.236
	4	18.500	7 H 8 H 9 H	16.000	16.355 16.450 16.560	4 H	14.000	14.375
20	2	20.500	7 H 8 H 9 H	19.000	19.265 19.335 19.425	4 H	18.000	18.236
	4	20.500	7 H 8 H 9 H	18.000	18.355 18.450 18.560	4 H	16.000	16.375
22	3	22.500	7 H 8 H 9 H	20.500	20.800 20.875 20.975	4 H	19.000	19.315
	5	22.500	7 H 8 H 9 H	19.500	19.875 19.975 20.100	4 H	17.000	17.450
	8	23.000	7 H 8 H 9 H	18.000	18.475 18.600 18.750	4 H	14.000	14.630
24	3	24.500	7 H 8 H 9 H	22.500	22.835 22.925 23.030	4 H	21.000	21.315
	5	24.500	7 H 8 H 9 H	21.500	21.900 22.000 22.130	4 H	19.000	19.450

续表 1

mm

公称直径 $D$	螺距 $P$	大 径 $D_1 = D_{1\min}$	中 径			小 径		
			公差带	最小尺寸 $D_{2\min}$	最大尺寸 $D_{2\max}$	公差带	最小尺寸 $D_{1\min}$	最大尺寸 $D_{1\max}$
24	8	25.000	7 H	20.000	20.500	4 H	16.000	16.630
			8 H		20.630			
			9 H		20.800			
26	3	26.500	7 H	24.500	24.835	4 H	23.000	23.315
			8 H		24.925			
			9 H		25.030			
	5	26.500	7 H	23.500	23.900	4 H	21.000	21.450
			8 H		24.000			
			9 H		24.130			
8	27.000	7 H	22.000	22.500	4 H	18.000	18.630	
		8 H		22.630				
		9 H		22.800				
28	3	28.500	7 H	26.500	26.835	4 H	25.000	25.315
			8 H		26.925			
			9 H		27.030			
	5	28.500	7 H	25.500	25.900	4 H	23.000	23.450
			8 H		26.000			
			9 H		26.130			
8	29.000	7 H	24.000	24.500	4 H	20.000	20.630	
		8 H		24.630				
		9 H		24.800				
30	3	30.500	7 H	28.500	28.835	4 H	27.000	27.315
			8 H		28.925			
			9 H		29.030			
	6	31.000	7 H	27.000	27.450	4 H	24.000	24.500
			8 H		27.560			
			9 H		27.710			

续表 1

mm

公称直径 $D$	螺距 $P$	大 径 $D_1 = D_{1min}$	中 径			小 径		
			公差带	最小尺寸 $D_{2min}$	最大尺寸 $D_{2max}$	公差带	最小尺寸 $D_{1min}$	最大尺寸 $D_{1max}$
30	10	31.000	7 H	25.000	25.530	4 H	20.000	20.710
			8 H		25.670			
			9 H		25.850			
32	3	32.500	7 H	30.500	30.835	4 H	29.000	29.315
			8 H		30.925			
			9 H		31.030			
	6	33.000	7 H	29.000	29.450	4 H	26.000	26.500
			8 H		29.560			
			9 H		29.710			
10	33.000	7 H	27.000	27.530	4 H	22.000	22.710	
		8 H		27.670				
		9 H		27.850				
34	3	34.500	7 H	32.500	32.835	4 H	31.000	31.315
			8 H		32.925			
			9 H		33.030			
	6	35.000	7 H	31.000	31.450	4 H	28.000	28.500
			8 H		31.560			
			9 H		31.710			
10	35.000	7 H	29.000	29.530	4 H	24.000	24.710	
		8 H		29.670				
		9 H		29.850				
36	3	36.500	7 H	34.500	34.835	4 H	33.000	33.315
			8 H		34.925			
			9 H		35.030			
	6	37.000	7 H	33.000	33.450	4 H	30.000	30.500
				33.560				
				33.710				

续表 1

mm

公称直径 $D$	螺距 $P$	大 径 $D_4 = D_{4min}$	中 径			小 径		
			公差带	最小尺寸 $D_{2min}$	最大尺寸 $D_{2max}$	公差带	最小尺寸 $D_{1min}$	最大尺寸 $D_{1max}$
36	10	37.000	7 H	31.000	31.530	4 H	26.000	26.710
			8 H		31.670			
			9 H		31.850			
38	3	38.500	7 H	36.500	36.835	4 H	35.000	35.315
			8 H		36.925			
			9 H		37.030			
	7	39.000	7 H	34.500	34.975	4 H	31.000	31.560
			8 H		35.100			
			9 H		35.250			
10	39.000	7 H	33.000	33.530	4 H	28.000	28.710	
		8 H		33.670				
		9 H		33.850				
40	3	40.500	7 H	38.500	38.835	4 H	37.000	37.315
			8 H		38.925			
			9 H		39.030			
	7	41.000	7 H	36.500	36.975	4 H	33.000	33.560
			8 H		37.100			
			9 H		37.250			
10	41.000	7 H	35.000	35.530	4 H	30.000	30.710	
		8 H		35.670				
		9 H		35.850				
42	3	42.500	7 H	40.500	40.835	4 H	39.000	39.315
			8 H		40.925			
			9 H		41.030			
	7	43.000	7 H	38.500	38.975	4 H	35.000	35.560
			8 H		39.100			
			9 H		39.250			

续表 1

mm

公称直径 $D$	螺距 $P$	大 径 $D_4 = D_{4min}$	中 径			小 径		
			公差带	最小尺寸 $D_{2min}$	最大尺寸 $D_{2max}$	公差带	最小尺寸 $D_{1min}$	最大尺寸 $D_{1max}$
42	10	43.000	7 H	37.000	37.530	4 H	32.000	32.710
			8 H		37.670			
			9 H		37.850			
44	3	44.500	7 H	42.500	42.835	4 H	41.000	41.315
			8 H		42.925			
			9 H		43.030			
	7	45.000	7 H	40.500	40.975	4 H	37.000	37.580
			8 H		41.100			
			9 H		41.250			
12	45.000	7 H	38.000	38.560	4 H	32.000	32.800	
		8 H		38.710				
		9 H		38.900				
46	3	46.500	7 H	44.500	44.855	4 H	43.000	43.315
			8 H		44.950			
			9 H		45.060			
	8	47.000	7 H	42.000	42.530	4 H	38.000	38.630
			8 H		42.670			
			9 H		42.850			
12	47.000	7 H	40.000	40.630	4 H	34.000	34.800	
		8 H		40.800				
		9 H		41.000				
48	3	48.500	7 H	46.500	46.855	4 H	45.000	45.315
			8 H		46.950			
			9 H		47.060			
	8	49.000	7 H	44.000	44.530	4 H	40.000	40.630
			8 H		44.670			
			9 H		44.850			



续表 1

mm

公称直径 $D$	螺距 $P$	大 径 $D_4 = D_{4min}$	中 径			小 径		
			公差带	最小尺寸 $D_{2min}$	最大尺寸 $D_{2max}$	公差带	最小尺寸 $D_{1min}$	最大尺寸 $D_{1max}$
48	12	49.000	7 H	42.000	42.630	4 H	38.000	36.800
			8 H		42.800			
			9 H		43.000			
50	3	50.500	7 H	48.500	48.855	4 H	47.000	47.315
			8 H		48.950			
			9 H		49.060			
	8	51.000	7 H	46.000	46.530	4 H	42.000	42.630
			8 H		46.670			
			9 H		46.850			
12	51.000	7 H	44.000	44.630	4 H	38.000	38.800	
		8 H		44.800				
		9 H		45.000				
52	3	52.500	7 H	50.500	50.855	4 H	49.000	49.315
			8 H		50.950			
			9 H		51.060			
	8	53.000	7 H	48.000	48.530	4 H	44.000	44.630
			8 H		48.670			
			9 H		48.850			
12	53.000	7 H	46.000	46.630	4 H	40.000	40.800	
		8 H		46.800				
		9 H		47.000				
55	3	55.500	7 H	53.500	53.855	4 H	52.000	52.315
			8 H		53.950			
			9 H		54.060			
	9	56.000	7 H	50.500	51.060	4 H	46.000	46.670
8 H	51.210							
9 H	51.400							

续表 1

mm

公称直径 $D$	螺距 $P$	大 径 $D_4 = D_{4 \min}$	中 径			小 径		
			公差带	最小尺寸 $D_{2 \min}$	最大尺寸 $D_{2 \max}$	公差带	最小尺寸 $D_{1 \min}$	最大尺寸 $D_{1 \max}$
55	14	57.000	7 H	48.000	48.670	4 H	41.000	41.900
			8 H		48.850			
			9 H		49.060			
60	3	60.500	7 H	58.500	58.855	4 H	57.000	57.315
			8 H		58.950			
			9 H		59.060			
	9	61.000	7 H	55.500	56.060	4 H	51.000	51.670
			8 H		56.210			
			9 H		56.400			
14	62.000	7 H	53.000	53.670	4 H	46.000	46.900	
		8 H		53.850				
		9 H		54.060				
65	4	65.500	7 H	63.000	63.400	4 H	61.000	61.375
			8 H		63.500			
			9 H		63.630			
	10	66.000	7 H	60.000	60.560	4 H	55.000	55.710
			8 H		60.710			
			9 H		60.900			
16	67.000	7 H	57.000	57.710	4 H	49.000	50.000	
		8 H		57.900				
		9 H		58.120				
70	4	70.500	7 H	68.000	68.400	4 H	66.000	66.375
			8 H		68.500			
			9 H		68.630			
	10	71.000	7 H	65.000	65.560	4 H	60.000	60.710
8 H			65.710					
9 H			65.900					

续表 1

mm

公称直径 $D$	螺距 $P$	大 径 $D_4 = D_{4\min}$	中 径			小 径		
			公差带	最小尺寸 $D_{2\min}$	最大尺寸 $D_{2\max}$	公差带	最小尺寸 $D_{1\min}$	最大尺寸 $D_{1\max}$
70	16	72.000	7 H	62.000	62.710	4 H	54.000	55.000
			8 H		62.900			
			9 H		63.120			
75	4	75.500	7 H	73.000	73.400	4 H	71.000	71.375
			8 H		73.500			
			9 H		73.630			
	10	76.000	7 H	70.000	70.560	4 H	65.000	65.710
			8 H		70.710			
			9 H		70.900			
16	77.000	7 H	67.000	67.710	4 H	59.000	60.000	
		8 H		67.900				
		9 H		68.120				
80	4	80.500	7 H	78.000	78.400	4 H	76.000	76.375
			8 H		78.500			
			9 H		78.630			
	10	81.000	7 H	75.000	75.560	4 H	70.000	70.710
			8 H		75.710			
			9 H		75.900			
16	82.000	7 H	72.000	72.710	4 H	64.000	65.000	
		8 H		72.900				
		9 H		73.120				
85	4	85.500	7 H	83.000	83.400	4 H	81.000	81.375
			8 H		83.500			
			9 H		83.630			
	12	86.000	7 H	79.000	79.630	4 H	73.000	73.800
8 H	79.800							
9 H	80.000							

续表 1

mm

公称直径 $D$	螺距 $P$	大 径 $D_4 = D_{4\min}$	中 径			小 径		
			公差带	最小尺寸 $D_{2\min}$	最大尺寸 $D_{2\max}$	公差带	最小尺寸 $D_{1\min}$	最大尺寸 $D_{1\max}$
85	18	87.000	7 H	76.000	76.750	4 H	67.000	68.120
			8 H		76.950			
			9 H		77.180			
90	4	90.500	7 H	88.000	88.400	4 H	86.000	86.375
			8 H		88.500			
			9 H		88.630			
	12	91.000	7 H	84.000	84.630	4 H	78.000	78.800
			8 H		84.800			
			9 H		85.000			
18	92.000	7 H	81.000	81.750	4 H	72.000	73.120	
		8 H		81.950				
		9 H		82.180				
95	4	95.500	7 H	93.000	93.425	4 H	91.000	91.375
			8 H		93.530			
			9 H		93.670			
	12	96.000	7 H	89.000	89.670	4 H	83.000	83.800
			8 H		89.850			
			9 H		90.060			
18	97.000	7 H	86.000	86.800	4 H	77.000	78.120	
		8 H		87.000				
		9 H		87.250				
100	4	100.500	7 H	98.000	98.425	4 H	96.000	96.375
			8 H		98.530			
			9 H		98.670			
	12	101.000	7 H	94.000	94.670	4 H	88.000	88.800
8 H	94.850							
9 H	95.060							

续表 1

mm

公称直径 $D$	螺距 $P$	大 径 $D_1 = D_{1 \min}$	中 径			小 径		
			公差带	最小尺寸 $D_{2 \min}$	最大尺寸 $D_{2 \max}$	公差带	最小尺寸 $D_{1 \min}$	最大尺寸 $D_{1 \max}$
100	20	102.000	7 H	90.000	90.800	4 H	80.000	81.180
			8 H		91.000			
			9 H		91.250			
110	4	110.500	7 H	108.000	108.425	4 H	106.000	106.375
			8 H		108.530			
			9 H		108.670			
	12	111.000	7 H	104.000	104.670	4 H	98.000	98.800
			8 H		104.850			
			9 H		105.060			
20	112.000	7 H	100.000	100.800	4 H	90.000	91.180	
		8 H		101.000				
		9 H		101.250				
120	6	121.000	7 H	117.000	117.500	4 H	114.000	114.500
			8 H		117.630			
			9 H		117.800			
	14	122.000	7 H	113.000	113.710	4 H	106.000	106.900
			8 H		113.900			
			9 H		114.120			
22	122.000	7 H	109.000	109.850	4 H	98.000	99.250	
		8 H		110.060				
		9 H		110.320				
130	6	131.000	7 H	127.000	127.500	4 H	124.000	124.500
			8 H		127.630			
			9 H		127.800			
	14	132.000	7 H	123.000	123.710	4 H	116.000	116.900
			8 H		123.900			
			9 H		124.120			

续表 1

mm

公称直径 $D$	螺距 $P$	大 径 $D_1 = D_{1 \min}$	中 径			小 径		
			公差带	最小尺寸 $D_{2 \min}$	最大尺寸 $D_{2 \max}$	公差带	最小尺寸 $D_{1 \min}$	最大尺寸 $D_{1 \max}$
130	22	132.000	7 H	119.000	119.850	4 H	108.000	109.250
			8 H		120.060			
			9 H		120.320			
140	6	141.000	7 H	137.000	137.500	4 H	134.000	134.500
			8 H		137.630			
			9 H		137.800			
	14	142.000	7 H	133.000	133.710	4 H	126.000	126.900
			8 H		133.900			
			9 H		134.120			
24	142.000	7 H	128.000	128.900	4 H	116.000	117.320	
		8 H		129.120				
		9 H		129.400				
150	6	151.000	7 H	147.000	147.500	4 H	144.000	144.500
			8 H		147.630			
			9 H		147.800			
	16	152.000	7 H	142.000	142.750	4 H	134.000	135.000
			8 H		142.950			
			9 H		143.180			
24	152.000	7 H	138.000	138.900	4 H	126.000	127.320	
		8 H		139.120				
		9 H		139.400				
160	6	161.000	7 H	157.000	157.500	4 H	154.000	154.500
			8 H		157.630			
			9 H		157.800			
	16	162.000	7 H	152.000	152.750	4 H	144.000	145.000
			8 H		152.950			
			9 H		153.180			

续表 1

mm

公称直径 $D$	螺距 $P$	大 径 $D_1 = D_{1min}$	中 径			小 径		
			公差带	最小尺寸 $D_{2min}$	最大尺寸 $D_{2max}$	公差带	最小尺寸 $D_{1min}$	最大尺寸 $D_{1max}$
160	28	162.000	7 H	146.000	146.950	4 H	132.000	133.500
			8 H		147.180			
			9 H		147.500			
170	6	171.000	7 H	167.000	167.500	4 H	164.000	164.500
			8 H		167.630			
			9 H		167.800			
	16	172.000	7 H	162.000	162.750	4 H	154.000	155.000
			8 H		162.950			
			9 H		163.180			
28	172.000	7 H	156.000	156.950	4 H	142.000	143.500	
		8 H		157.180				
		9 H		157.500				
180	8	181.000	7 H	176.000	176.560	4 H	172.000	172.630
			8 H		176.710			
			9 H		176.900			
	18	182.000	7 H	171.000	171.800	4 H	162.000	163.120
			8 H		172.000			
			9 H		172.250			
28	182.000	7 H	166.000	166.950	4 H	152.000	153.500	
		8 H		167.180				
		9 H		167.500				
190	8	191.000	7 H	186.000	186.000	4 H	182.000	182.630
			8 H		186.750			
			9 H		186.950			
	18	192.000	7 H	181.000	181.850	4 H	172.000	173.120
			8 H		182.060			
			9 H		182.320			

GB 12359-90

续表 1

mm

公称直径 $D$	螺距 $P$	大 径 $D_1 = D_{1min}$	中 径			小 径		
			公差带	最小尺寸 $D_{2min}$	最大尺寸 $D_{2max}$	公差带	最小尺寸 $D_{1min}$	最大尺寸 $D_{1max}$
190	32	192.000	7 H	174.000	175.060	4 H	158.000	159.600
			8 H		175.320			
			9 H		175.700			
	8	201.000	7 H	196.000	196.600	4 H	192.000	192.630
			8 H		196.750			
			9 H		196.950			
200	13	202.000	7 H	191.000	191.850	4 H	182.000	183.120
			8 H		192.060			
			9 H		192.320			
	32	202.000	7 H	184.000	185.060	4 H	168.000	169.600
			8 H		185.320			
			9 H		185.700			
	8	211.000	7 H	206.000	206.600	4 H	202.000	202.630
			8 H		206.750			
			9 H		206.950			
210	20	212.000	7 H	200.000	200.900	4 H	190.000	191.180
			8 H		201.120			
			9 H		201.400			



续表 1

mm

公称直径 $D$	螺距 $P$	大 径 $D_4 = D_{4 \min}$	中 径			小 径		
			公差带	最小尺寸 $D_{2 \min}$	最大尺寸 $D_{2 \max}$	公差带	最小尺寸 $D_{1 \min}$	最大尺寸 $D_{1 \max}$
220	36	222.000	7 H	202.000	203.120	4 H	184.000	185.800
			8 H		203.400			
			9 H		203.800			
230	8	231.000	7 H	226.000	226.600	4 H	222.000	222.630
			8 H		226.750			
			9 H		226.950			
	20	232.000	7 H	220.000	220.900	4 H	210.000	211.180
			8 H		221.120			
			9 H		221.400			
36	232.000	7 H	212.000	213.120	4 H	194.000	195.800	
		8 H		213.400				
		9 H		213.800				
240	8	241.000	7 H	236.000	236.600	4 H	232.000	232.630
			8 H		236.750			
			9 H		236.950			
	22	242.000	7 H	229.000	229.900	4 H	218.000	219.250
			8 H		230.120			
			9 H		230.400			
36	242.000	7 H	222.000	223.120	4 H	204.000	205.800	
		8 H		223.400				
		9 H		223.800				
250	12	251.000	7 H	244.000	244.710	4 H	238.000	238.800
			8 H		244.900			
			9 H		245.120			
	22	252.000	7 H	239.000	4 H	228.000	229.250	
8 H	240.120							
9 H	240.400							



续表 1

mm

公称直径 $D$	螺距 $P$	大径 $D_4 = D_{4 \min}$	中 径			小 径		
			公差带	最小尺寸 $D_{2 \min}$	最大尺寸 $D_{2 \max}$	公差带	最小尺寸 $D_{1 \min}$	最大尺寸 $D_{1 \max}$
280	40	282.000	7 H	260.000	261.120	4 H	240.000	241.900
			8 H		261.400			
			9 H		261.800			
290	12	291.000	7 H	284.000	284.710	4 H	278.000	278.800
			8 H		284.900			
			9 H		285.120			
	24	292.000	7 H	278.000	278.950	4 H	266.000	267.320
			8 H		279.180			
			9 H		279.500			
44	292.000	7 H	268.000	269.250	4 H	246.000	248.000	
		8 H		269.500				
		9 H		269.900				
300	12	301.000	7 H	294.000	294.710	4 H	288.000	288.800
			8 H		294.900			
			9 H		295.120			
	24	302.000	7 H	288.000	288.950	4 H	276.000	277.320
			8 H		289.180			
			9 H		289.500			
44	302.000	7 H	278.000	279.250	4 H	256.000	258.000	
		8 H		279.500				
		9 H		279.900				

## 4 外螺纹的极限尺寸

4.1 外螺纹公差带位置见图 2。

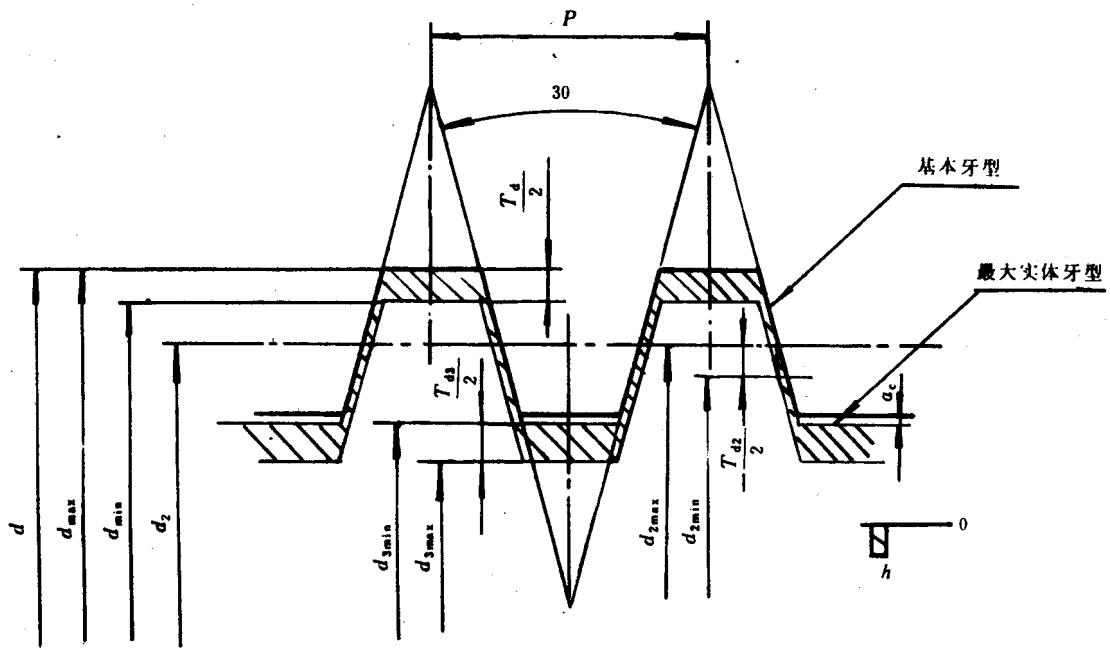

a. 大、中、小径的公差带位置为  $h$

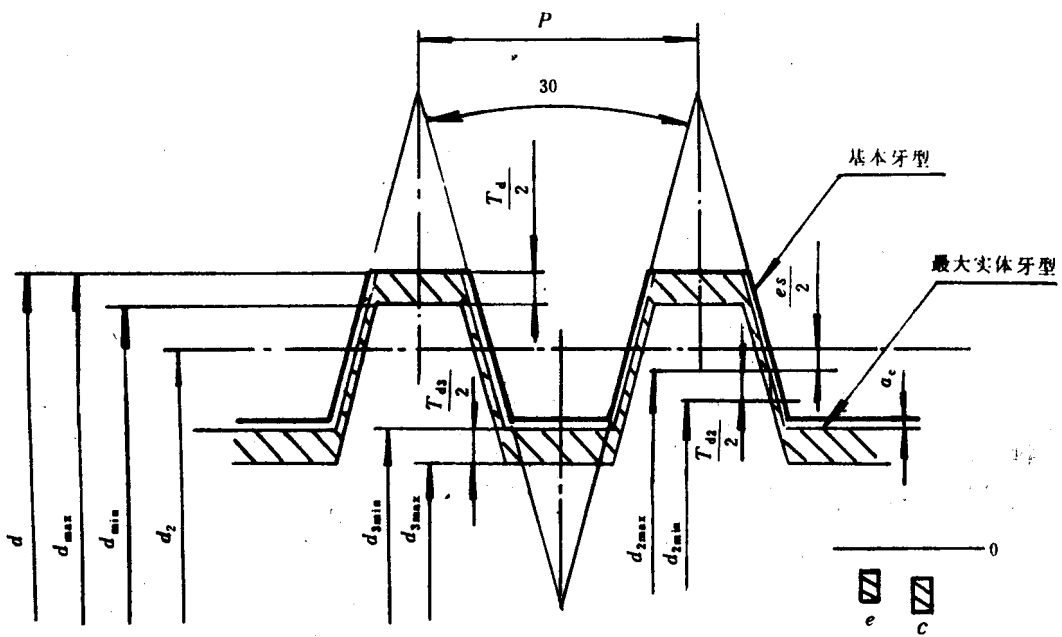

b. 大、小径的公差带位置为  $h$ ，中径为  $e$ 、 $c$

图 2 外螺纹公差带

- 图中： $d$ ——外螺纹公称直径；  
 $d_{max}$ ——外螺纹大径最大尺寸；  
 $d_{min}$ ——外螺纹大径最小尺寸；  
 $d_2$ ——外螺纹中径基本尺寸；  
 $d_{2max}$ ——外螺纹中径最大尺寸；  
 $d_{2min}$ ——外螺纹中径最小尺寸；  
 $d_{3max}$ ——外螺纹小径最大尺寸；

$d_{3\min}$ ——外螺纹小径最小尺寸；

$P$ ——螺距；

$a_c$ ——牙顶间隙。

#### 4.2 计算公式

外螺纹大径（公差带位置均为 $h$ ）：

$$d_{\max} = d + es_h;$$

$$d_{\min} = d + es_h - T_d;$$

$$es_h = 0。$$

外螺纹中径（公差带位置为 $h$ 、 $e$ 、 $c$ ）：

$$d_{2\max} = d_2 + es;$$

$$d_{2\min} = d_2 + es - T_{d2};$$

$$es_h = 0。$$

$es_e$ 、 $es_c$  值见GB 5796.4中表1。

外螺纹小径（公差带位置均为 $h$ ）：

$$d_{3\max} = d_3 + es_h;$$

$$d_{3\min} = d_3 + es_h - T_{d3};$$

$$es_h = 0。$$

式中： $d$ ——外螺纹大径基本尺寸；

$d_2$ ——外螺纹中径基本尺寸；

$d_3$ ——外螺纹小径基本尺寸；

$T_d$ ——外螺纹大径公差；

$T_{d2}$ ——外螺纹中径公差；

$T_{d3}$ ——外螺纹小径公差；

$es_h$ ——公差带位置为 $h$ 的基本偏差；

$es_e$ ——公差带位置为 $e$ 的基本偏差；

$es_c$ ——公差带位置为 $c$ 的基本偏差。

#### 4.3 外螺纹极限尺寸见表2。

表2 外螺纹极限尺寸

mm

公称直径 $d$	螺距 $P$	大 径			中 径			小 径	
		公差带	最大尺寸 $d_{\max}$	最小尺寸 $d_{\min}$	公差带	最大尺寸 $d_{2\max}$	最小尺寸 $d_{2\min}$	最大尺寸 $d_{3\max}$	最小尺寸 $d_{3\min}$
8	1.5	4h	8.000	7.850	7h	7.250	7.080	6.200	5.988
					7e	7.183	7.013		5.921
					8e	7.183	6.971		5.868
					8c	7.110	6.898		5.795
					9c	7.110	6.845		5.729

续表 2

mm

公称直径 $d$	螺距 $P$	大 径			中 径			小 径	
		公差带	最大尺寸 $d_{max}$	最小尺寸 $d_{min}$	公差带	最大尺寸 $d_{2max}$	最小尺寸 $d_{2min}$	最大尺寸 $d_{3max}$	最小尺寸 $d_{3min}$
9	1.5	4h	9.000	8.850	7h	8.250	8.080	7.200	6.988
					7e	8.183	8.013		6.921
					8e	8.183	7.971		6.868
					8c	8.110	7.898		6.795
					9c	8.110	7.845		6.729
	2	4h	9.000	8.820	7h	8.000	7.810	6.500	6.262
					7e	7.929	7.739		6.191
					8e	7.929	7.693		6.134
					8c	7.850	7.614		6.055
					9c	7.850	7.550		5.975
10	1.5	4h	10.000	9.850	7h	9.250	9.080	8.200	7.988
					7e	9.183	9.013		7.921
					8e	9.183	8.971		7.868
					8c	9.110	8.898		7.795
					9c	9.110	8.845		7.729
	2	4h	10.000	9.820	7h	9.000	8.810	7.500	7.262
					7e	8.929	8.739		7.191
					8e	8.929	8.693		7.134
					8c	8.850	8.614		7.055
					9c	8.850	8.550		6.975
11	2	4h	11.000	10.820	7h	10.000	9.810	8.500	8.262
					7e	9.929	9.739		8.191
					8e	9.929	9.693		8.134
					8c	9.850	9.614		8.055
					9c	9.850	9.550		7.975
	3	4h	11.000	10.764	7h	9.500	9.288	7.500	7.235
					7e	9.415	9.203		7.150
					8e	9.415	9.150		7.084
					8c	9.330	9.065		6.999
					9c	9.330	8.995		6.911

续表 2

mm

公称直径 $d$	螺 距 $P$	大 径			中 径			小 径	
		公差带	最大尺寸 $d_{max}$	最小尺寸 $d_{min}$	公差带	最大尺寸 $d_{2max}$	最小尺寸 $d_{2min}$	最大尺寸 $d_{3max}$	最小尺寸 $d_{3min}$
12	2	4h	12.000	11.820	7h	11.000	10.800	9.500	9.250
					7e	10.929	10.729		9.179
					8e	10.929	10.679		9.117
					8c	10.850	10.600		9.038
					9c	10.850	10.535		8.956
	3	4h	12.000	11.764	7h	10.500	10.276	8.500	8.220
					7e	10.415	10.191		8.135
					8e	10.415	10.135		8.065
					8c	10.330	10.050		7.980
					9c	10.330	9.975		7.886
14	2	4h	14.000	13.820	7h	13.000	12.800	11.500	11.250
					7e	12.929	12.729		11.179
					8e	12.929	12.679		11.117
					8c	12.850	12.600		11.038
					9c	12.850	12.535		10.956
	3	4h	14.000	13.764	7h	12.500	12.276	10.500	10.220
					7e	12.415	12.191		10.135
					8e	12.415	12.135		10.065
					8c	12.330	12.050		9.980
					9c	12.330	11.975		9.866
16	2	4h	16.000	15.820	7h	15.000	14.800	13.500	13.250
					7e	14.929	14.729		13.179
					8e	14.929	14.679		13.117
					8c	14.850	14.600		13.038
					9c	14.850	14.535		12.956
	4	4h	16.000	15.700	7h	14.000	13.735	11.500	11.169
					7e	13.905	13.640		11.074
					8e	13.905	13.570		10.986
					8c	13.810	13.475		10.891
					9c	13.810	13.385		10.810

续表 2

mm

公称直径 $d$	螺 距 $P$	大 径			中 径			小 径	
		公差带	最大尺寸 $d_{max}$	最小尺寸 $d_{min}$	公差带	最大尺寸 $d_{2max}$	最小尺寸 $d_{2min}$	最大尺寸 $d_{3max}$	最小尺寸 $d_{3min}$
18	2	4 h	18.000	17.820	7h	17.000	16.800	15.500	15.250
					7e	16.929	16.729		15.179
					8e	16.929	16.679		15.117
					8c	16.850	16.600		15.038
					9c	16.850	16.535		14.956
	4	4 h	18.000	17.700	7h	16.000	15.735	13.500	13.169
					7e	15.905	15.640		13.074
					8e	15.905	15.570		12.986
					8c	15.810	15.475		12.891
					9c	15.810	15.385		12.810
20	2	4 h	20.000	19.820	7h	19.000	18.800	17.500	17.250
					7e	18.929	18.729		17.179
					8e	18.929	18.679		17.117
					8c	18.850	18.600		17.038
					9c	18.850	18.535		16.956
	4	4 h	20.000	19.700	7h	18.000	17.735	15.500	15.169
					7e	17.905	17.640		15.074
					8e	17.905	17.570		14.986
					8c	17.810	17.475		14.891
					9c	17.810	17.385		14.810
22	3	4 h	22.000	21.764	7h	20.500	20.276	18.500	18.220
					7e	20.415	20.191		18.135
					8e	20.415	20.135		18.065
					8c	20.330	20.050		17.980
					9c	20.330	19.975		17.886
	5	4 h	22.000	21.665	7h	19.500	19.220	16.500	16.150
					7e	19.394	19.114		16.044
					8e	19.394	19.039		15.950
					8c	19.288	18.933		15.844
					9c	19.288	18.838		15.725



续表 2

mm

公称直径 $d$	螺距 $P$	大 径			中 径			小 径	
		公差带	最大尺寸 $d_{max}$	最小尺寸 $d_{min}$	公差带	最大尺寸 $d_{2max}$	最小尺寸 $d_{2min}$	最大尺寸 $d_{3max}$	最小尺寸 $d_{3min}$
22	8	4h	22.000	21.550	7h	18.000	17.645	13.000	12.556
					7e	17.868	17.513		12.424
					8e	17.868	17.418		12.305
					8c	17.735	17.285		12.172
					9c	17.735	17.175		12.035
24	3	4h	24.000	23.764	7h	22.500	22.250	20.500	20.188
					7e	22.415	22.165		20.103
					8e	22.415	22.100		20.021
					8c	22.330	22.015		19.936
					9c	22.330	21.930		19.830
	5	4h	24.000	23.665	7h	21.500	21.200	18.500	18.125
					7e	21.394	21.094		18.019
					8e	21.394	21.019		17.925
					8c	21.288	20.913		17.819
					9c	21.288	20.813		17.694
	8	4h	24.000	23.550	7h	20.000	19.625	15.000	14.531
					7e	19.868	19.493		14.399
					8e	19.868	19.393		14.274
					8c	19.735	19.260		14.141
					9c	19.735	19.135		13.985
26	3	4h	26.000	25.764	7h	24.500	24.250	22.500	22.188
					7e	24.415	24.165		22.103
					8e	24.415	24.100		22.021
					8c	24.330	24.015		21.936
					9c	24.330	23.930		21.830
	5	4h	26.000	25.665	7h	23.500	23.200	20.500	20.125
					7e	23.394	23.094		20.019
					8e	23.394	23.019		19.925
					8c	23.288	22.913		19.819
					9c	23.288	22.813		19.694

续表 2

mm

公称直径 $d$	螺距 $P$	大 径			中 径			小 径	
		公差带	最大尺寸 $d_{max}$	最小尺寸 $d_{min}$	公差带	最大尺寸 $d_{2max}$	最小尺寸 $d_{2min}$	最大尺寸 $d_{3max}$	最小尺寸 $d_{3min}$
26	8	4h	26.000	25.550	7h	22.000	21.625	17.000	16.531
					7e	21.868	21.493		16.399
					8e	21.868	21.393		16.274
					8c	21.735	21.260		16.141
					9c	21.735	21.135		15.985
28	3	4h	28.000	27.764	7h	26.500	26.250	24.500	24.188
					7e	26.415	26.165		24.103
					8e	26.415	26.100		24.021
					8c	26.330	26.015		23.936
					9c	26.330	25.930		23.830
	5	4h	28.000	27.665	7h	25.500	25.200	22.500	22.125
					7e	25.394	25.094		22.019
					8e	25.394	25.019		21.925
					8c	25.288	24.913		21.819
					9c	25.288	24.813		21.694
8	4h	28.000	27.550	7h	24.000	23.625	19.000	18.531	
				7e	23.868	23.493		18.399	
				8e	23.868	23.393		18.274	
				8c	23.735	23.260		18.141	
				9c	23.735	23.135		17.985	
30	3	4h	30.000	29.764	7h	28.500	28.250	26.500	26.188
					7e	28.415	28.165		26.103
					8e	28.415	28.100		26.021
					8c	28.330	28.015		25.936
					9c	28.330	27.930		25.830
	6	4h	30.000	29.625	7h	27.000	26.665	23.000	22.581
					7e	26.882	26.547		22.463
					8e	26.882	26.457		22.351
					8c	26.764	26.339		22.233
					9c	26.764	26.234		22.101

续表 2

mm

公称直径 $d$	螺 距 $P$	大 径			中 径			小 径	
		公差带	最大尺寸 $d_{max}$	最小尺寸 $d_{min}$	公差带	最大尺寸 $d_{2max}$	最小尺寸 $d_{2min}$	最大尺寸 $d_{3max}$	最小尺寸 $d_{3min}$
30	10	4h	30.000	29.470	7h	25.000	24.600	19.000	18.500
					7e	24.850	24.450		18.350
					8e	24.850	24.350		18.225
					8c	24.700	24.200		18.075
					9c	24.700	24.070		17.913
32	3	4h	32.000	31.764	7h	30.500	30.250	28.500	28.188
					7e	30.415	30.165		28.103
					8e	30.415	30.100		28.021
					8c	30.330	30.015		27.936
					9c	30.330	29.930		27.830
	6	4h	32.000	31.625	7h	29.000	28.665	25.000	24.581
					7e	28.882	28.547		24.463
					8e	28.882	28.457		24.351
					8c	28.764	28.339		24.233
					9c	28.764	28.234		24.101
	10	4h	32.000	31.470	7h	27.000	26.600	21.000	20.500
					7e	26.850	26.450		20.350
					8e	26.850	26.350		20.225
					8c	26.700	26.200		20.075
					9c	26.700	26.070		19.913
34	3	4h	34.000	33.764	7h	32.500	32.250	30.500	30.188
					7e	32.415	32.165		30.103
					8e	32.415	32.100		30.021
					8c	32.330	32.015		29.936
					9c	32.330	31.930		29.830
	6	4h	34.000	33.625	7h	31.000	30.665	27.000	26.581
					7e	30.882	30.547		26.463
					8e	30.882	30.457		26.351
					8c	30.764	30.339		26.233
					9c	30.764	30.234		26.101

续表 2

mm

公称直径 $d$	螺距 $P$	大 径			中 径			小 径	
		公差带	最大尺寸 $d_{max}$	最小尺寸 $d_{min}$	公差带	最大尺寸 $d_{2max}$	最小尺寸 $d_{2min}$	最大尺寸 $d_{3max}$	最小尺寸 $d_{3min}$
34	10	4h	34.000	33.470	7h	29.000	28.600	23.000	22.500
					7e	28.850	28.450		22.350
					8e	28.850	28.350		22.225
					8c	28.700	28.200		22.075
					9c	28.700	28.070		21.913
36	3	4h	36.000	35.764	7h	34.500	34.250	32.500	32.188
					7e	34.415	34.165		32.103
					8e	34.415	34.100		32.021
					8c	34.330	34.015		31.936
					9c	34.330	33.930		31.830
	6	4h	36.000	35.625	7h	33.000	32.665	29.000	28.581
					7e	32.882	32.547		28.463
					8e	32.882	32.457		28.351
					8c	32.764	32.339		28.233
					9c	32.764	32.234		28.101
	10	4h	36.000	35.470	7h	31.000	30.600	25.000	24.500
					7e	30.850	30.450		24.350
					8e	30.850	30.350		24.225
					8c	30.700	30.200		24.075
					9c	30.700	30.070		23.913
38	3	4h	38.000	37.764	7h	36.500	36.250	34.500	34.188
					7e	36.415	36.165		34.103
					8e	36.415	36.100		34.021
					8c	36.330	36.015		33.936
					9c	36.330	35.930		33.830
	7	4h	38.000	37.575	7h	34.500	34.145	30.000	29.556
					7e	34.375	34.020		29.431
					8e	34.375	33.925		29.312
					8c	34.250	33.800		29.187
					9c	34.250	33.690		29.050

续表 2

mm

公称直径 $d$	螺距 $P$	大 径			中 径			小 径	
		公差带	最大尺寸 $d_{max}$	最小尺寸 $d_{min}$	公差带	最大尺寸 $d_{2max}$	最小尺寸 $d_{2min}$	最大尺寸 $d_{3max}$	最小尺寸 $d_{3min}$
38	10	4h	38.000	37.470	7h	33.000	32.600	27.000	26.500
					7e	32.850	32.450		26.350
					8e	32.850	32.350		26.225
					8c	32.700	32.200		26.075
					9c	32.700	32.070		25.913
40	3	4h	40.000	39.764	7h	38.500	38.250	36.500	36.188
					7e	38.415	38.165		36.103
					8e	38.415	38.100		36.021
					8c	38.330	38.015		35.936
					9c	38.330	37.930		35.830
	7	4h	40.000	39.575	7h	36.500	36.145	32.000	31.556
					7e	36.375	36.020		31.431
					8e	36.375	35.925		31.312
					8c	36.250	35.800		31.187
					9c	36.250	35.690		31.050
	10	4h	40.000	39.470	7h	35.000	34.600	29.000	28.500
					7e	34.850	34.450		28.350
8e					34.850	34.350	28.225		
8c					34.700	34.200	28.075		
9c					34.700	34.070	27.913		
42	3	4h	42.000	41.764	7h	40.500	40.250	38.500	38.188
					7e	40.415	40.165		38.103
					8e	40.415	40.100		38.021
					8c	40.330	40.015		37.936
					9c	40.330	39.930		37.830
	7	4h	42.000	41.575	7h	38.500	38.145	34.000	33.556
					7e	38.375	38.020		33.431
					8e	38.375	37.925		33.312
					8c	38.250	37.800		33.187
					9c	38.250	37.690		33.050

续表 2

mm

公称直径 $d$	螺距 $P$	大 径			中 径			小 径	
		公差带	最大尺寸 $d_{max}$	最小尺寸 $d_{min}$	公差带	最大尺寸 $d_{2max}$	最小尺寸 $d_{2min}$	最大尺寸 $d_{3max}$	最小尺寸 $d_{3min}$
42	10	4h	42.000	41.470	7h	37.000	36.600	31.000	30.500
					7e	36.850	36.450		30.350
					8e	36.850	36.350		30.225
					8c	36.700	36.200		30.075
					9c	36.700	36.070		29.913
44	3	4h	44.000	43.764	7h	42.500	42.250	40.500	40.188
					7e	42.415	42.165		40.103
					8e	42.415	42.100		40.021
					8c	42.330	42.015		39.936
					9c	42.330	41.930		39.830
	7	4h	44.000	43.575	7h	40.500	40.145	36.000	35.556
					7e	40.375	40.020		35.431
					8e	40.375	39.925		35.312
					8c	40.250	39.800		35.187
					9c	40.250	39.690		35.050
	12	4h	44.000	43.400	7h	38.000	37.575	31.000	30.469
					7e	37.840	37.415		30.309
					8e	37.840	37.310		30.177
					8c	37.665	37.135		30.002
					9c	37.665	36.995		29.777
46	3	4h	46.000	45.764	7h	44.500	44.235	42.500	42.169
					7e	44.415	44.150		42.084
					8e	44.415	44.080		41.996
					8c	44.330	43.995		41.911
					9c	44.330	43.905		41.799
	8	4h	46.000	45.550	7h	42.000	41.600	37.000	36.500
					7e	41.868	41.468		36.368
					8e	41.868	41.368		36.243
					8c	41.735	41.235		36.110
					9c	41.735	41.105		35.948

续表 2

mm

公称直径 $d$	螺距 $P$	大 径			中 径			小 径	
		公差带	最大尺寸 $d_{max}$	最小尺寸 $d_{min}$	公差带	最大尺寸 $d_{2max}$	最小尺寸 $d_{2min}$	最大尺寸 $d_{3max}$	最小尺寸 $d_{3min}$
46	12	4h	46.000	45.400	7h	40.000	39.525	33.000	32.406
					7e	39.840	39.365		32.246
					8e	39.840	39.240		32.090
					8c	39.665	39.065		31.915
					9c	39.665	38.915		31.727
48	3	4h	48.000	47.764	7h	46.500	46.235	44.500	44.169
					7e	46.415	46.150		44.084
					8e	46.415	46.080		43.996
					8c	46.330	45.995		43.911
					9c	46.330	45.905		43.799
	8	4h	48.000	47.550	7h	44.000	43.600	39.000	38.500
					7e	43.868	43.468		38.368
					8e	43.868	43.368		38.243
					8c	43.735	43.235		38.110
					9c	43.735	43.105		37.948
	12	4h	48.000	47.400	7h	42.000	41.525	35.000	34.406
					7e	41.840	41.365		34.246
					8e	41.840	41.240		34.090
					8c	41.665	41.065		33.915
					9c	41.665	40.915		33.727
50	3	4h	50.000	49.764	7h	48.500	48.235	46.500	46.169
					7e	48.415	48.150		46.084
					8e	48.415	48.080		45.996
					8c	48.330	47.995		45.911
					9c	48.330	47.905		45.799
	8	4h	50.000	49.550	7h	46.000	45.600	41.000	40.500
					7e	45.868	45.468		40.368
					8e	45.868	45.368		40.243
					8c	45.735	45.235		40.110
					9c	45.735	45.105		39.948

续表 2

mm

公称直径 $d$	螺距 $P$	大 径			中 径			小 径	
		公差带	最大尺寸 $d_{max}$	最小尺寸 $d_{min}$	公差带	最大尺寸 $d_{2max}$	最小尺寸 $d_{2min}$	最大尺寸 $d_{3max}$	最小尺寸 $d_{3min}$
50	12	4h	50.000	49.400	7h	44.000	43.525	37.000	36.406
					7e	43.840	43.365		36.246
					8e	43.840	43.240		36.090
					8c	43.665	43.065		35.915
					9c	43.665	42.915		35.727
52	3	4h	52.000	51.764	7h	50.500	50.235	48.500	48.169
					7e	50.415	50.150		48.084
					8e	50.415	50.080		47.996
					8c	50.330	49.995		47.911
					9c	50.330	49.905		47.799
	8	4h	52.000	51.550	7h	48.000	47.600	43.000	42.500
					7e	47.868	47.468		42.368
					8e	47.868	47.368		42.243
					8c	47.735	47.235		42.110
					9c	47.735	47.105		41.948
	12	4h	52.000	51.400	7h	46.000	45.525	39.000	38.406
					7e	45.840	45.365		38.246
					8e	45.840	45.240		38.090
					8c	45.665	45.065		37.915
					9c	45.665	44.915		37.727
55	3	4h	55.000	54.764	7h	53.500	53.235	51.500	51.169
					7e	53.415	53.150		51.084
					8e	53.415	53.080		50.996
					8c	53.330	52.995		50.911
					9c	53.330	52.905		50.799
	9	4h	55.000	54.500	7h	50.500	50.075	45.000	44.469
					7e	50.360	49.935		44.329
					8e	50.360	49.830		44.197
					8c	50.220	49.690		44.057
					9c	50.220	49.550		43.882



续表 2

mm

公称直径 $d$	螺距 $P$	大 径			中 径			小 径	
		公差带	最大尺寸 $d_{max}$	最小尺寸 $d_{min}$	公差带	最大尺寸 $d_{2max}$	最小尺寸 $d_{2min}$	最大尺寸 $d_{3max}$	最小尺寸 $d_{3min}$
55	14	4h	55.000	54.330	7h	48.000	47.500	39.000	38.375
					7e	47.820	47.320		38.195
					8e	47.820	47.190		38.033
					8c	47.645	47.015		37.858
					9c	47.645	46.845		37.645
60	3	4h	60.000	59.764	7h	58.500	58.235	56.500	56.169
					7e	58.415	68.150		56.084
					8e	58.415	58.080		56.996
					8c	58.330	57.995		56.911
					9c	58.330	57.905		56.799
	9	4h	60.000	59.500	7h	55.500	55.075	50.000	49.469
					7e	55.360	54.935		49.329
					8e	55.360	54.830		49.197
					8c	55.220	54.690		49.057
					9c	55.220	54.550		48.882
	14	4h	60.000	59.330	7h	53.000	52.500	44.000	43.375
					7e	52.820	52.320		43.195
					8e	52.820	52.190		43.033
					8c	52.645	52.015		42.858
					9c	52.645	51.845		42.645
65	4	4h	65.000	64.700	7h	63.000	62.700	60.500	60.125
					7e	62.905	62.605		60.030
					8e	62.905	62.530		59.936
					8c	62.810	62.435		59.841
					9c	62.810	62.335		59.716
	10	4h	65.000	64.470	7h	60.000	59.575	54.000	53.469
					7e	59.850	59.425		53.319
					8e	59.850	59.320		53.187
					8c	59.700	59.170		53.037
					9c	59.700	59.030		52.862

续表 2

mm

公称直径 $d$	螺距 $P$	大 径			中 径			小 径	
		公差带	最大尺寸 $d_{max}$	最小尺寸 $d_{min}$	公差带	最大尺寸 $d_{2max}$	最小尺寸 $d_{2min}$	最大尺寸 $d_{3max}$	最小尺寸 $d_{3min}$
65	16	4h	65.000	64.290	7h	57.000	56.470	47.000	46.338
					7e	56.810	56.280		46.147
					8e	56.810	56.140		45.972
					8c	56.625	55.955		45.787
					9c	56.625	55.775		45.562
70	4	4h	70.000	69.700	7h	68.000	67.700	65.500	65.125
					7e	67.905	67.605		65.030
					8e	67.905	67.530		64.936
					8c	67.810	67.435		64.841
					9c	67.810	67.335		64.716
	10	4h	70.000	69.470	7h	65.000	64.575	59.000	58.469
					7e	64.850	64.425		58.319
					8e	64.850	64.320		58.187
					8c	64.700	64.170		58.037
					9c	64.700	64.030		57.862
	16	4h	70.000	69.290	7h	62.000	61.470	52.000	51.338
					7e	61.810	61.280		51.147
8e					61.810	61.140	50.972		
8c					61.625	60.955	50.787		
9c					61.625	60.775	50.562		
75	4	4h	75.000	74.700	7h	73.000	72.700	70.500	70.125
					7e	72.905	72.605		70.030
					8e	72.905	72.530		69.936
					8c	72.810	72.435		69.841
					9c	72.810	72.335		69.716
	10	4h	75.000	74.470	7h	70.000	69.575	64.000	63.469
					7e	69.850	69.425		63.319
					8e	69.850	69.320		63.187
					8c	69.700	69.170		63.037
					9c	69.700	69.030		62.862

续表 2

mm

公称直径 $d$	螺距 $P$	大 径			中 径			小 径	
		公差带	最大尺寸 $d_{max}$	最小尺寸 $d_{min}$	公差带	最大尺寸 $d_{2max}$	最小尺寸 $d_{2min}$	最大尺寸 $d_{3max}$	最小尺寸 $d_{3min}$
75	16	4h	75.000	74.290	7h	67.000	66.470	57.000	56.338
					7e	66.810	66.280		56.147
					8e	66.810	66.140		55.972
					8c	66.625	65.955		55.787
					9c	66.625	65.775		55.562
80	4	4h	80.000	79.700	7h	78.000	77.700	75.500	75.125
					7e	77.905	77.605		75.030
					8e	77.905	77.530		74.936
					8c	77.810	77.435		74.841
					9c	77.810	77.335		74.716
	10	4h	80.000	79.470	7h	75.000	74.575	69.000	68.469
					7e	74.850	74.425		68.319
					8e	74.850	74.320		68.187
					8c	74.700	74.170		68.037
					9c	74.700	74.030		67.862
	16	4h	80.000	79.290	7h	72.000	71.470	62.000	61.338
					7e	71.810	71.280		61.147
8e					71.810	71.140	60.972		
8c					71.625	70.955	60.787		
9c					71.625	70.775	60.562		
85	4	4h	85.000	84.700	7h	83.000	82.700	80.500	80.125
					7e	82.905	82.605		80.030
					8e	82.905	82.530		79.936
					8c	82.810	82.435		79.841
					9c	82.810	82.335		79.716
	12	4h	85.000	84.400	7h	79.000	78.525	72.000	71.406
					7e	78.840	78.365		71.246
					8e	78.840	78.240		71.090
					8c	78.665	78.065		70.915
					9c	78.665	77.915		70.727

续表 2

mm

公称直径 $d$	螺距 $P$	大 径			中 径			小 径	
		公差带	最大尺寸 $d_{max}$	最小尺寸 $d_{min}$	公差带	最大尺寸 $d_{2max}$	最小尺寸 $d_{2min}$	最大尺寸 $d_{3max}$	最小尺寸 $d_{3min}$
85	18	4h	85.000	84.200	7h	76.000	75.440	65.000	64.300
					7e	75.800	75.240		64.100
					8e	75.800	75.090		63.912
					8c	75.600	74.890		63.712
					9c	75.600	74.700		63.475
90	4	4h	90.000	89.700	7h	88.000	87.700	85.500	85.125
					7e	87.905	87.605		85.030
					8e	87.905	87.530		84.936
					8c	87.810	87.435		84.841
					9c	87.810	87.335		84.716
	12	4h	90.000	89.400	7h	84.000	83.525	77.000	76.406
					7e	83.840	83.365		76.246
					8e	83.840	83.240		76.090
					8c	83.665	83.065		75.915
					9c	83.665	82.915		75.727
	18	4h	90.000	89.200	7h	81.000	80.440	70.000	69.300
					7e	80.800	80.240		69.100
					8e	80.800	80.090		68.912
					8c	80.600	79.890		68.712
					9c	80.600	79.700		68.475
95	4	4h	95.000	94.700	7h	93.000	92.685	90.500	90.106
					7e	92.905	92.590		90.011
					8e	92.905	92.505		89.905
					8c	92.810	92.410		89.810
					9c	92.810	92.310		89.685
	12	4h	95.000	94.400	7h	89.000	88.500	82.000	81.375
					7e	88.840	88.340		81.215
					8e	88.840	88.210		81.053
					8c	88.665	88.035		80.878
					9c	88.665	87.865		80.665

续表 2

mm

公称直径 $d$	螺距 $P$	大 径			中 径			小 径	
		公差带	最大尺寸 $d_{max}$	最小尺寸 $d_{min}$	公差带	最大尺寸 $d_{2max}$	最小尺寸 $d_{2min}$	最大尺寸 $d_{3max}$	最小尺寸 $d_{3min}$
95	18	4h	95.000	94.200	7h	86.000	85.400	75.000	74.250
					7e	85.800	85.200		74.050
					8e	85.800	85.050		73.862
					8c	85.600	84.850		73.662
					9c	85.600	84.650		73.412
100	4	4h	100.000	99.700	7h	98.000	97.685	95.500	95.106
					7e	97.905	97.590		95.011
					8e	97.905	97.505		94.905
					8c	97.810	97.410		94.810
					9c	97.810	97.310		94.685
	12	4h	100.000	99.400	7h	94.000	93.500	87.000	86.375
					7e	93.840	93.340		86.215
					8e	93.840	93.210		86.053
					8c	93.665	93.035		85.878
					9c	93.665	92.865		85.665
	20	4h	100.000	99.150	7h	90.000	89.400	78.000	77.250
					7e	89.788	89.188		77.038
					8e	89.788	89.038		76.850
					8c	89.575	88.825		76.637
					9c	89.575	88.625		76.387
110	4	4h	110.000	109.100	7h	108.000	107.685	105.500	105.106
					7e	107.905	107.590		105.011
					8e	107.905	107.505		104.905
					8c	107.810	107.410		104.810
					9c	107.810	107.310		104.685
	12	4h	110.000	109.400	7h	104.000	103.500	97.000	96.375
					7e	103.840	103.340		96.215
					8e	103.840	103.210		96.053
					8c	103.665	103.035		95.878
					9c	103.665	102.865		95.665

续表 2

mm

公称直径 $d$	螺距 $P$	大 径			中 径			小 径	
		公差带	最大尺寸 $d_{max}$	最小尺寸 $d_{min}$	公差带	最大尺寸 $d_{2max}$	最小尺寸 $d_{2min}$	最大尺寸 $d_{3max}$	最小尺寸 $d_{3min}$
110	20	4h	110.000	109.150	7h	100.000	99.400	88.000	87.250
					7e	99.788	99.188		87.038
					8e	99.788	99.038		86.850
					8c	99.575	98.825		86.637
					9c	99.575	98.625		86.387
120	6	4h	120.000	119.625	7h	117.000	116.625	113.000	112.531
					7e	116.882	116.507		112.413
					8e	116.882	116.407		112.288
					8c	116.764	116.289		112.170
					9c	116.764	116.164		112.014
	14	4h	120.000	119.330	7h	113.000	112.470	104.000	103.338
					7e	112.820	112.290		103.157
					8e	112.820	112.150		102.982
					8c	112.645	111.975		102.807
					9c	112.645	111.795		102.582
	22	4h	120.000	119.100	7h	109.000	108.370	96.000	95.212
					7e	108.776	108.146		94.989
					8e	108.776	107.976		94.776
					8c	108.550	107.750		94.550
					9c	108.550	107.550		94.300
130	6	4h	130.000	129.625	7h	127.000	126.625	123.000	122.531
					7e	126.882	126.507		122.413
					8e	126.882	126.407		122.288
					8c	126.764	126.289		122.170
					9c	126.764	126.164		122.014
	14	4h	130.000	129.330	7h	123.000	122.470	114.000	113.388
					7e	122.820	122.290		113.157
					8e	122.820	122.150		112.982
					8c	122.645	121.975		112.807
					9c	122.645	121.795		112.582

续表 2

mm

公称直径 $d$	螺距 $P$	大 径			中 径			小 径	
		公差带	最大尺寸 $d_{max}$	最小尺寸 $d_{min}$	公差带	最大尺寸 $d_{2max}$	最小尺寸 $d_{2min}$	最大尺寸 $d_{3max}$	最小尺寸 $d_{3min}$
130	22	4h	130.000	129.100	7h	119.000	118.370	106.000	105.212
					7e	118.776	118.146		104.989
					8e	118.776	117.976		104.776
					8c	118.550	117.750		104.550
					9c	118.550	117.550		104.300
140	6	4h	140.000	139.625	7h	137.000	136.625	133.000	132.531
					7e	136.882	136.507		132.413
					8e	136.882	136.407		132.288
					8c	136.764	136.289		132.170
					9c	136.764	136.164		132.014
	14	4h	140.000	139.330	7h	133.000	132.470	124.000	123.338
					7e	132.820	132.290		123.157
					8e	132.820	132.150		122.982
					8c	132.645	131.975		122.807
					9c	132.645	131.795		122.582
	24	4h	140.000	139.050	7h	128.000	127.330	114.000	113.162
					7e	127.764	127.094		112.926
					8e	127.764	126.914		112.701
					8c	127.525	126.675		112.462
					9c	127.525	126.465		112.200
150	6	4h	150.000	149.625	7h	147.000	146.625	143.000	142.531
					7e	146.882	146.507		142.413
					8e	146.882	146.407		142.288
					8c	146.764	146.289		142.170
					9c	146.764	146.164		142.014
	16	4h	150.000	149.290	7h	142.000	141.440	132.000	131.300
					7e	141.810	141.250		131.110
					8e	141.810	141.100		130.922
					8c	141.625	140.915		130.737
					9c	141.625	140.725		130.500

续表 2

mm

公称直径 $d$	螺距 $P$	大 径			中 径			小 径	
		公差带	最大尺寸 $d_{max}$	最小尺寸 $d_{min}$	公差带	最大尺寸 $d_{2max}$	最小尺寸 $d_{2min}$	最大尺寸 $d_{3max}$	最小尺寸 $d_{3min}$
150	24	4h	150.000	149.050	7h	138.000	137.330	124.000	123.162
					7e	137.764	137.094		122.926
					8e	137.764	136.914		122.761
					8c	137.525	136.675		122.462
					9c	137.525	136.465		122.200
160	6	4h	160.000	159.625	7h	157.000	156.625	153.000	152.531
					7e	156.882	156.507		152.413
					8e	156.882	156.407		152.288
					8c	156.764	156.289		152.170
					9c	156.764	156.164		152.014
	16	4h	160.000	159.290	7h	152.000	151.440	142.000	141.300
					7e	151.810	151.250		141.110
					8e	151.810	151.100		140.922
					8c	151.625	150.915		140.737
					9c	151.625	150.725		140.500
	28	4h	160.000	158.940	7h	146.000	145.290	130.000	129.112
					7e	145.750	145.040		128.862
					8e	145.750	144.850		128.625
					8c	145.500	144.600		128.375
					9c	145.500	144.380		128.100
170	6	4h	170.000	169.625	7h	167.000	166.623	163.000	162.531
					7e	166.882	166.507		162.413
					8e	166.882	166.407		162.288
					8c	166.764	166.289		162.170
					9c	166.764	166.164		162.014
	16	4h	170.000	169.290	7h	162.000	161.400	152.000	151.300
					7e	161.810	161.250		151.110
					8e	161.810	161.100		150.922
					8c	161.625	160.915		150.737
					9c	161.625	160.725		150.500



续表 2

mm

公称直径 $d$	螺距 $P$	大 径			中 径			小 径	
		公差带	最大尺寸 $d_{max}$	最小尺寸 $d_{min}$	公差带	最大尺寸 $d_{2max}$	最小尺寸 $d_{2min}$	最大尺寸 $d_{3max}$	最小尺寸 $d_{3min}$
170	28	4h	170.000	168.940	7h	156.000	155.290	140.000	139.112
					7e	155.750	155.040		138.862
					8e	155.750	154.850		138.625
					8c	155.500	154.600		138.375
					9c	155.500	154.380		138.100
180	8	4h	180.000	179.550	7h	176.000	175.575	171.000	170.469
					7e	175.868	175.443		170.337
					8e	175.868	175.338		170.205
					8c	175.735	175.205		170.072
					9c	175.735	175.065		169.897
	18	4h	180.000	179.200	7h	171.000	170.400	160.000	159.250
					7e	170.800	170.200		159.050
					8e	170.800	170.050		158.862
					8c	170.600	169.850		158.662
					9c	170.600	169.650		158.412
	28	4h	180.000	178.940	7h	166.000	165.290	150.000	149.112
					7e	165.750	165.040		148.862
8e					165.750	165.850	148.625		
8c					165.500	164.600	148.375		
9c					165.500	164.380	148.100		
190	8	4h	190.000	189.550	7h	186.000	185.550	181.000	180.438
					7e	185.868	185.418		180.305
					8e	185.868	185.308		180.168
					8c	185.735	185.175		180.035
					9c	185.735	185.025		179.847
	18	4h	190.000	189.200	7h	181.000	180.370	170.000	169.212
					7e	180.800	180.170		169.013
					8e	180.800	180.000		168.800
					8c	180.600	179.800		168.600
					9c	180.600	179.600		168.350

续表 2

mm

公称直径 $d$	螺距 $P$	大 径			中 径			小 径	
		公差带	最大尺寸 $d_{max}$	最小尺寸 $d_{min}$	公差带	最大尺寸 $d_{2max}$	最小尺寸 $d_{2min}$	最大尺寸 $d_{3max}$	最小尺寸 $d_{3min}$
190	32	4h	190.000	188.880	7h	174.000	173.200	156.000	155.000
					7e	173.735	172.935		154.735
					8e	173.735	172.735		154.485
					8c	173.470	172.470		154.220
					9c	173.470	172.220		153.908
200	8	4h	200.000	199.550	7h	196.000	195.550	191.000	190.438
					7e	195.868	195.418		190.305
					8e	195.868	195.308		190.168
					8c	195.735	195.175		190.035
					9c	195.735	195.025		189.847
	18	4h	200.000	199.200	7h	191.000	190.370	180.000	179.212
					7e	190.800	190.170		179.613
					8e	190.800	190.000		178.800
					8c	190.600	189.800		178.600
					9c	190.600	189.600		178.350
	32	4h	200.000	198.880	7h	184.000	183.200	166.000	165.000
					7e	183.735	182.935		164.735
					8e	183.735	182.735		164.485
					8c	183.470	182.470		164.220
					9c	183.470	182.220		163.908
210	8	4h	210.000	209.550	7h	206.000	205.550	201.000	200.438
					7e	205.868	205.418		200.305
					8e	205.868	205.308		200.168
					8c	205.735	205.175		200.035
					9c	205.735	205.025		199.847
	20	4h	210.000	209.150	7h	200.000	199.330	188.000	187.162
					7e	199.788	199.118		186.950
					8e	199.788	198.938		186.725
					8c	199.575	198.725		186.512
					9c	199.575	198.515		186.250

续表 2

mm

公称直径 $d$	螺距 $P$	大 径			中 径			小 径	
		公差带	最大尺寸 $d_{max}$	最小尺寸 $d_{min}$	公差带	最大尺寸 $d_{2max}$	最小尺寸 $d_{2min}$	最大尺寸 $d_{3max}$	最小尺寸 $d_{3min}$
210	36	4 h	210.000	208.750	7 h	192.000	191.150	172.000	170.938
					7 e	191.720	190.870		170.657
					8 e	191.720	190.660		170.395
					8 c	191.440	190.380		170.115
					9 c	191.440	190.120		169.790
220	8	4 h	220.000	219.550	7 h	216.000	215.550	211.000	210.438
					7 e	215.868	215.418		210.305
					8 e	215.868	215.308		210.168
					8 c	215.735	215.175		210.035
					9 c	215.735	215.025		209.847
	20	4 h	220.000	219.150	7 h	210.000	209.330	198.000	197.162
					7 e	209.788	209.118		196.950
					8 e	209.788	208.938		196.725
					8 c	209.575	208.725		196.512
					9 c	209.575	208.515		196.250
	36	4 h	220.000	218.750	7 h	202.000	201.150	182.000	180.938
					7 e	201.720	200.870		180.657
					8 e	201.720	200.660		180.395
					8 c	201.440	200.380		180.115
					9 c	201.440	200.120		179.790
230	8	4 h	230.000	229.550	7 h	226.000	225.550	221.000	220.438
					7 e	225.868	225.418		220.305
					8 e	225.868	225.308		220.168
					8 c	225.735	225.175		220.035
					9 c	225.735	225.025		219.847
	20	4 h	230.000	229.150	7 h	220.000	219.330	208.000	207.162
					7 e	219.788	219.118		206.950
					8 e	219.788	218.938		206.725
					8 c	219.575	218.725		206.512
					9 c	219.575	218.515		206.250

续表 2

mm

公称直径 $d$	螺距 $P$	大 径			中 径			小 径	
		公差带	最大尺寸 $d_{max}$	最小尺寸 $d_{min}$	公差带	最大尺寸 $d_{2max}$	最小尺寸 $d_{2min}$	最大尺寸 $d_{3max}$	最小尺寸 $d_{3min}$
230	36	4 h	230.000	228.750	7 h	212.000	211.150	192.000	190.938
					7 e	211.720	210.870		190.657
					8 e	211.720	210.660		190.395
					8 c	211.440	210.380		190.115
					9 c	211.440	210.120		189.790
240	8	4 h	240.000	239.550	7 h	236.000	235.550	231.000	230.438
					7 e	235.868	235.418		230.305
					8 e	235.868	235.308		230.168
					8 c	235.735	235.175		230.035
					9 c	235.735	235.025		229.847
	22	4 h	240.000	239.100	7 h	229.000	228.330	216.000	215.162
					7 e	228.776	228.106		214.938
					8 e	228.776	227.926		214.713
					8 c	228.550	227.700		214.487
					9 c	228.550	227.490		214.225
	36	4 h	240.000	238.750	7 h	222.000	221.150	202.000	200.938
					7 e	221.720	220.870		200.657
					8 e	221.720	220.660		200.395
8 c					221.440	220.380	200.115		
9 c					221.440	220.120	199.790		
250	12	4 h	250.000	249.400	7 h	244.000	243.470	237.000	236.338
					7 e	243.840	243.310		236.177
					8 e	243.840	243.170		236.002
					8 c	243.665	242.995		235.827
					9 c	243.665	242.815		235.602
	22	4 h	250.000	249.100	7 h	239.000	238.330	226.000	225.162
					7 e	238.776	238.106		224.938
					8 e	238.776	237.926		224.713
					8 c	238.550	237.700		224.487
					9 c	238.550	237.490		224.225

续表 2

mm

公称直径 $d$	螺距 $P$	大 径			中 径			小 径	
		公差带	最大尺寸 $d_{max}$	最小尺寸 $d_{min}$	公差带	最大尺寸 $d_{2max}$	最小尺寸 $d_{2min}$	最大尺寸 $d_{3max}$	最小尺寸 $d_{3min}$
250	40	4 h	250.000	248.680	7 h	230.000	229.150	208.000	206.938
					7 e	229.700	228.850		206.637
					8 e	229.700	228.640		206.375
					8 c	229.400	228.340		206.075
					9 c	229.400	228.080		205.750
260	12	4 h	260.000	259.400	7 h	254.000	253.470	247.000	246.338
					7 e	253.810	253.310		246.177
					8 e	253.840	253.170		246.002
					8 c	253.665	252.995		245.827
					9 c	253.665	252.815		245.602
	22	4 h	260.000	259.100	7 h	249.000	248.330	236.000	235.162
					7 e	248.776	248.106		234.938
					8 e	248.776	247.926		234.713
					8 c	248.550	247.700		234.487
					9 c	248.550	247.490		234.225
	40	4 h	260.000	258.680	7 h	240.000	239.150	218.000	216.938
					7 e	239.700	238.850		216.637
					8 e	239.700	238.640		216.375
					8 c	239.400	238.340		216.075
					9 c	239.400	238.080		215.750
270	12	4 h	270.000	269.400	7 h	264.000	263.470	257.000	256.338
					7 e	263.840	263.310		256.177
					8 e	263.840	263.170		256.002
					8 c	263.665	262.995		255.827
					9 c	263.665	262.815		255.602
	24	4 h	270.000	269.050	7 h	258.000	257.290	244.000	243.112
					7 e	257.764	257.054		242.876
					8 e	257.764	256.864		242.639
					8 c	257.525	256.625		242.400
					9 c	257.525	256.405		242.125

续表 2

mm

公称直径 $d$	螺距 $P$	大 径			中 径			小 径	
		公差带	最大尺寸 $d_{max}$	最小尺寸 $d_{min}$	公差带	最大尺寸 $d_{2max}$	最小尺寸 $d_{2min}$	最大尺寸 $d_{3max}$	最小尺寸 $d_{3min}$
270	40	4 h	270.000	268.680	7 h	250.000	249.150	228.000	226.938
					7 e	249.700	248.850		226.637
					8 e	249.700	248.640		226.375
					8 c	249.400	248.340		226.075
					9 c	249.400	248.080		225.750
280	12	4 h	280.000	279.400	7 h	274.000	273.470	267.000	226.338
					7 e	273.840	273.310		226.177
					8 e	273.840	273.170		226.002
					8 c	273.665	272.995		265.827
					9 c	273.665	272.815		265.602
	24	4 h	280.000	279.050	7 h	268.000	267.290	254.000	253.112
					7 e	267.764	267.054		252.876
					8 e	267.764	266.864		252.639
					8 c	267.525	266.625		252.400
					9 c	267.525	266.405		252.125
	40	4 h	280.000	278.680	7 h	260.000	259.150	238.000	236.938
					7 e	259.700	258.850		236.637
					8 e	259.700	258.640		236.375
					8 c	259.400	258.340		236.075
					9 c	259.400	258.080		235.750
290	12	4 h	290.000	289.400	7 h	284.000	283.470	277.000	276.338
					7 e	283.840	283.310		276.177
					8 e	283.840	283.170		276.002
					8 c	283.665	282.995		275.827
					9 c	283.665	282.815		275.602
	24	4 h	290.000	289.050	7 h	278.000	277.290	264.000	263.112
					7 e	277.764	277.054		262.876
					8 e	277.764	276.864		262.639
					8 c	277.525	276.625		262.400
					9 c	277.525	276.405		262.125

续表 2

mm

公称直径 $d$	螺距 $P$	大 径			中 径			小 径	
		公差带	最大尺寸 $d_{max}$	最小尺寸 $d_{min}$	公差带	最大尺寸 $d_{2max}$	最小尺寸 $d_{2min}$	最大尺寸 $d_{3max}$	最小尺寸 $d_{3min}$
290	44	4 h	290.000	288.600	7 h	268.000	267.100	244.000	242.875
					7 e	267.685	266.785		242.560
					8 e	267.685	266.565		242.285
					8 c	267.370	266.250		241.970
					9 c	267.370	265.970		241.620
500	12	4 h	300.000	299.400	7 h	294.000	293.470	287.000	286.338
					7 e	293.840	293.310		286.177
					8 e	293.840	293.170		286.002
					8 c	293.665	292.995		285.827
					9 c	293.665	292.815		285.602
	24	4 h	300.000	299.050	7 h	288.000	287.290	274.000	273.112
					7 e	287.764	287.054		272.876
					8 e	287.764	286.864		272.639
					8 c	287.525	286.625		272.400
					9 c	287.525	286.405		272.125
	44	4 h	300.000	298.600	7 h	278.000	277.100	254.000	252.875
					7 e	277.685	276.785		252.560
					8 e	277.685	276.565		252.285
					8 c	277.370	276.250		251.970
					9 c	277.370	275.970		251.620

## 附加说明:

本标准由中华人民共和国机械电子工业部提出,由机械电子工业部机械标准化研究所归口。

本标准由机械电子工业部机械标准化研究所起草。

本标准主要起草人邓跃、于源。